

Spanntechnik **2021**

Clamping Tools

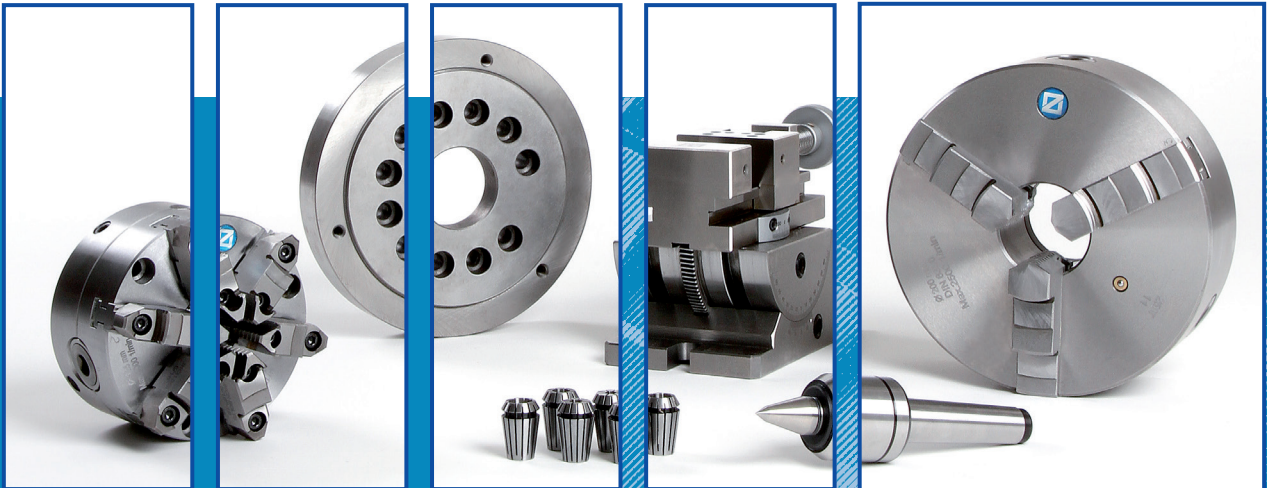



NEU/NEW



Spedition

Bei Artikeln mit diesem Symbol handelt es sich um sperrige, schwere Produkte die wir per Spedition versenden. Bitte beachten Sie, dass hier die Versandkosten gegenüber dem Paketversand abweichen können.

Carrier

Items with this symbol are bulky, heavy products that we send out by carrier. Please note, the shipping costs may differ compared to parcel shipping.

1

7-72

Drehfutter, Planscheiben, Kraftspannfutter, Spannzangenfutter und Zubehör

Lathe chucks, independent chucks, power chucks, collet chucks and accessories



- 12-27 [Planspiral-Drehfutter, Backen und Zubehör](#) / *Lathe chucks, jaws and accessories*
- 28-29 [Planspiral-Drehfutter und Backen BASIC](#) / *Lathe chucks and jaws BASIC*
- 30-31 [Keilstangen-Drehfutter und Backen](#) / *Wedge bar lathe chucks and jaws*
- 32-33 [Kombinierte Drehfutter Wescott und Backen](#) / *Wescott lathe chucks and jaws*
- 34-38 [Planscheiben](#) / *Independent chucks*
- 39-43 [Flansche](#) / *Adaptor plates*
- 44-45 [Drehfutter und Planscheiben mit großem Durchmesser](#) / *Big diameter chucks*
- 46-48 [Backen-Ausdrehringe und Ausdrehvorrichtungen](#) / *Jaw turning rings and fixtures*
- 48 [Drehfutteranschlätze](#) / *Work piece stops*
- 49-66 [Kraftspannfutter, Backen und Zubehör](#) / *Power chucks, jaws and accessories*
- 67-72 [Spannzangenfutter](#) / *Collet chucks*

2

73-96

Aufspannvorrichtungen, Prismenblöcke und Winkelprismen, Schraubböcke, Magnetspannplatten, Klauenkästen, Kreuz- und Schiebetische, Aufspannwinkel und Aufspannwürfel

Clamping fixtures, V-blocks and angle prisms, levelling screws, magnetic plates, box jaws, cross and slide tables, angle plates and clamping cubes



- 74-84 [Aufspannvorrichtungen](#) / *Clamping fixtures*
- 85-86 [Prismenblöcke und Winkelprismen](#) / *V-blocks and angle prisms*
- 87 [Schraubböcke](#) / *Levelling screws*
- 88 [Magnetspannplatten](#) / *Magnetic plates*
- 89 [Klauenkästen](#) / *Box jaws*
- 90-93 [Kreuz- und Schiebetische](#) / *Cross and slide tables*
- 94-95 [Aufspannwinkel](#) / *Angle plates*
- 96 [Aufspannwürfel](#) / *Clamping cubes*

Index

3

97-106

Hülsen und Dorne

Sleeves and arbors



4

107-112

Bohrfutter

Drill chucks



5

113-132

Körnerspitzen

Tailstock centres



6

133-160

Schraubstöcke

Vices

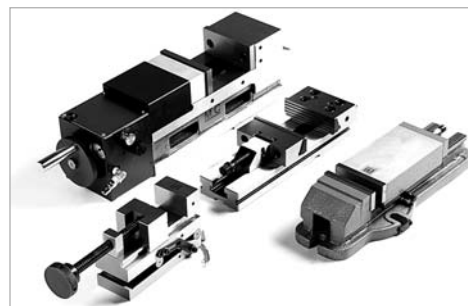

7

161-180

VDI-Werkzeughalter

VDI-Tool holders



8

181-188

Angetriebene Werkzeuge

Driven tools



Index

9

189-204

Spannzangen

Collets



10

205-214

Schnellwechselstahl- und Schleifbandhalter

Quick-change tool holders and sanding belt holders

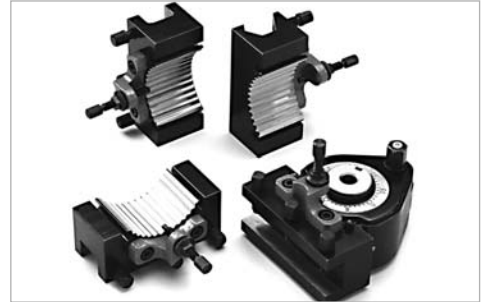

206-212

Schnellwechselstahlhalter / Quick-change tool holders

213

Schleifbandhalter / Sanding belt holders

11

215-248

Werkzeugaufnahmen für Fräsmaschinen MK-SK-Zylinderschaft-HSK

*Tool holders for milling machines
MT-SK-Straight shank-HSK*



216

Werkzeugaufnahmen-Sätze / Tool holder sets

217-219

Morsekegelaufnahmen / Morse taper tooling

219-222

DIN 2080 / DIN 2080

223-229

DIN 69871 / DIN 69871

230-235

MAS BT / MAS BT

236-239

Aufnahmen mit Zylinderschaft / Straight shank tooling

240-244

DIN 69893 HSK - A / DIN 69893 HSK - A

245-247

Anzugsbolzen / Pull studs

12

249-256

Ausdrehkopf-Sätze und Gewindeschneidfutter

Boring head sets and tapping chucks



250

[Ausdrehkopf-Sätze](#) / *Boring head sets*

251-253

[Gewindeschneid-Schnellwechselfutter](#) / *Quick-change tapping chucks*

254-255

[Synchron-Gewindeschneidfutter](#) / *Synchro-tapping chucks*

256

[Gewindeschneidapparate mit automatischem Rücklauf](#) / *Reversal tapping chucks*

13

257-270

Zubehör

Accessories



258

[Zubehör für Drehfutter und Planscheiben](#) / *Accessories for lathe and independent chucks*

259

[Zubehör für Schraubstöcke](#) / *Accessories for vices*

260-269

[Zubehör für Steilkegelaufnahmen](#) / *Accessories for SK tooling*

14

271-288

Messen - Prüfen - Einstellen

Measuring - Testing - Positioning



272-278

[Messen - Prüfen - Einstellen](#) / *Measuring - Testing - Positioning*

279

[Parallelunterlagen](#) / *Parallels*

280

[Endmaßsätze im Holzkasten](#) / *Gauge block sets in wooden case*

281

[Messstift-Sätze](#) / *Pin gauge sets*

282-285

[Grenz- und Gewindelehrdorne und Ringe](#) / *Plain and thread plug gauges and rings*

286

[Spannkraftmessgeräte](#) / *Clamping force meters*

286

[Anzugskraftmessgeräte](#) / *Tightening force meters*

287

[Aufspannsätze und Fräserkassetten](#) / *Clamping sets and milling cutters*

Index

15

289-310

Schutzeinrichtungen, Arbeitsleuchten und Schutzzäune

*Safety guards, work lamps
and safety panels*



290-305

Schutzeinrichtungen / *Safety guards*

306

Arbeitsleuchten / *Work lamps*

307-309

Schutzzäune / *Safety panels*

311-316

Stichwortverzeichnis *Keyword index*

317-318

Allgemeine Geschäftsbedingungen *Terms and conditions*

319-320

Notizen *Notes*

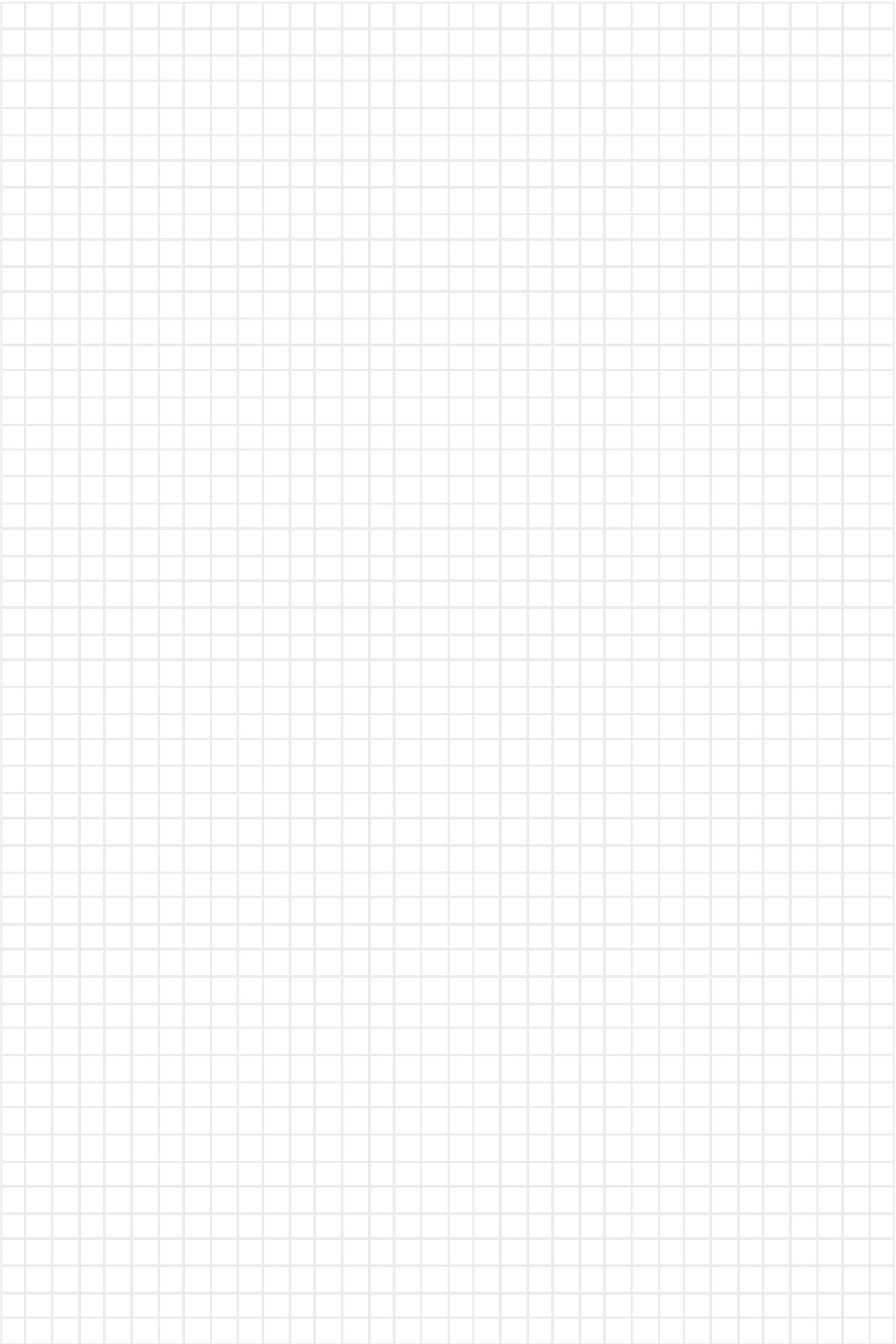

Drehfutter, Planscheiben, Kraftspannfutter, Spannzangenfutter und Zubehör

Lathe chucks, independent chucks, power chucks, collet chucks and accessories



■ Inhalt:

- 1.1 | Planspiral-Drehfutter, Backen und Zubehör
- 1.2 | Planspiral-Drehfutter und Backen BASIC
- 1.3 | Keilstangen-Drehfutter und Backen
- 1.4 | Wescott-Drehfutter und Backen
- 1.5 | Planscheiben
- 1.6 | Flansche
- 1.7 | Drehfutter und Planscheiben mit großem Ø
- 1.8 | Backen-Ausdrehringe
- 1.9 | Drehfutteranschlüge
- 1.10 | Kraftspannfutter, Backen und Zubehör
- 1.11 | Spannzangenfutter

■ Content:

- 1.1 | *Lathe chucks, jaws and accessories*
- 1.2 | *Lathe chucks and jaws BASIC*
- 1.3 | *Wedge bar lathe chucks and jaws*
- 1.4 | *Wescott lathe chucks and jaws*
- 1.5 | *Independent chucks*
- 1.6 | *Adaptor plates*
- 1.7 | *Big diameter chucks*
- 1.8 | *Jaw turning fixtures*
- 1.9 | *Work piece stops*
- 1.10 | *Power chucks, jaws and accessories*
- 1.11 | *Collet chucks*

Planspiral-Drehfutter

DIN 6350 | DIN 55026 | DIN 55027 | DIN 55029
 Dreh- und Bohrbacken | Grund- und Aufsatzbacken
 Guss | Stahl

Lathe chucks

DIN 6350 | DIN 55026 | DIN 55027 | DIN 55029
 One-piece jaws | Two-piece jaws
 Cast iron | Steel

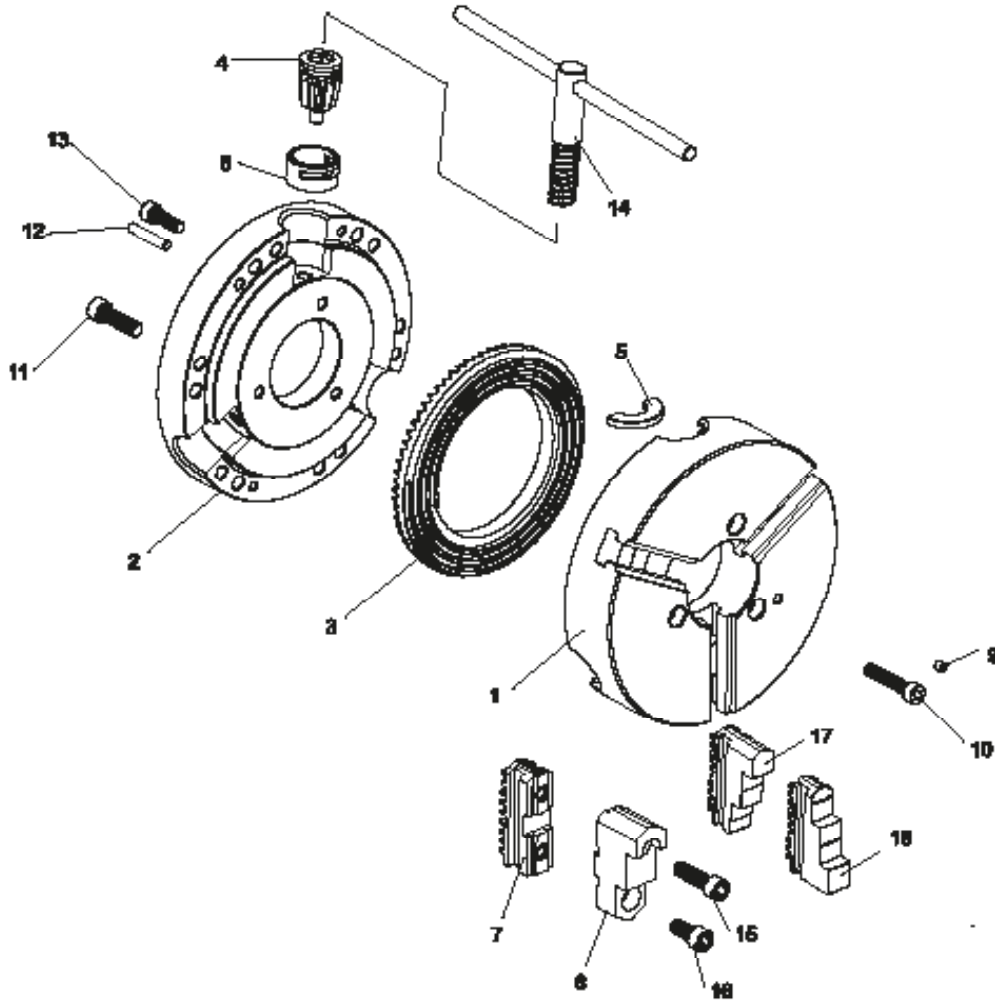

- 1. Futterkörper
- 2. Futterdeckel
- 3. Planspirale
- 4. Ritzel
- 5. Halbscheibe
- 6. Führungsbuchse
- 7. Grundbacke, hart
- 8. Aufsatzbacke, hart
- 9. Schmiernippel
- 10. Verschlusschraube
- 11. Befestigungsschraube
- 12. Passstift
- 13. Passschraube
- 14. Schlüssel
- 15. Schrauben für Backen
- 16. Schrauben für Backen
- 17. Bohrbacke
- 18. Drehbacke

- 1. Chuck body
- 2. Back cover
- 3. Scroll plate
- 4. Pinion
- 5. Pinion half ring
- 6. Pinion sleeve
- 7. Hard master jaw
- 8. Hard top jaw
- 9. Grease nipple
- 10. Back cover mounting bolt
- 11. Chuck mounting bolt
- 12. Back cover mounting pin
- 13. Back cover mounting bolts
- 14. Chuck wrench
- 15. Jaw mounting bolts
- 16. Jaw mounting bolts
- 17. Hard solid outside jaw
- 18. Hard solid inside jaw

Spindelnasen Spindle types

DIN 55026 | Typ A1 & A2 DIN 55026 | Type A1 & A2



Typ A1 mit Gewindebohrungen auf dem äußeren und inneren Lochkreisdurchmesser

Type A1 with tapped holes on both inner and outer bolt circles

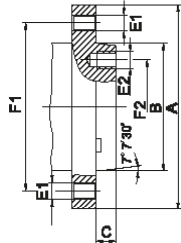

Typ A2 ohne Bohrungen auf dem inneren Lochkreisdurchmesser

Type A2 without holes on the inner bolt circle

KK / Taper	F1 (A2) mm	F2 (A1) mm	B mm	C mm	E1 / E2
4	82,6	-	63,521	11	M10
5	104,8	61,9	82,573	14,288	M10
6	133,4	82,6	106,385	15,875	M12
8	171,4	111,1	139,731	17,462	M16
11	235	165,1	196,883	19,05	M20
15	330,2	247,6	285,791	20,638	M24
20	463,6	368,3	412,795	22,225	M24

DIN 55027 | Typ C DIN 55027 | Type C

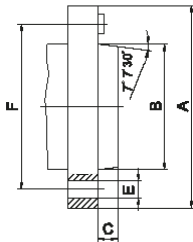

KK / Taper	A mm	F mm	B mm	C mm	E mm	Bohrungen / Holes
3	102	75	53,983	11	21	3
4	112	85	63,521	11	21	3
5	135	104,8	82,573	13	21	4
6	170	133,4	106,385	14	23	4
8	220	171,4	139,731	16	29	4
11	290	235	196,883	18	36	6
15	400	330,2	285,791	19	43	6

DIN 55029 | Camlock Typ D1 DIN 55029 | Camlock Type D1

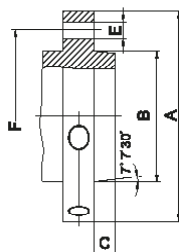
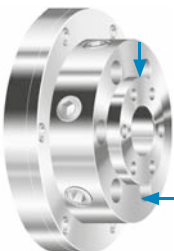

KK / Taper	A mm	F mm	B mm	C mm	E mm	Bohrungen / Holes
3	92	70,6	53,983	11	15,1	3
4	117	82,6	63,521	11	16,7	3
5	146	104,8	82,573	13	19,8	6
6	181	133,4	106,385	14	23	6
8	225	171,4	139,731	16	26,2	6
11	298	235	196,883	18	31	6
15	403	330,2	285,791	19	35,7	6

Futter für Maschinen mit Langkegel oder Gewindespindel auf Anfrage lieferbar
Chucks for machines with long taper or threaded spindle available upon request

Rundlauf-Genauigkeit Concentricity

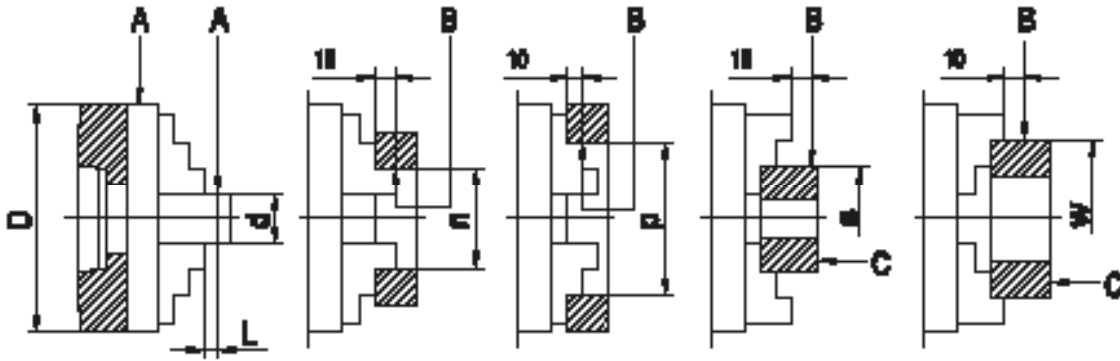

Drehfutter, Guss und Stahl Lathe chucks, cast iron and steel

Ø	d			L	n	p	s	W	W	Rundlauf / Radial runout		Planlauf / Axial runout
	1	2	3							A	B	C
80	10	-	14	40	40	60	35	63	-	0,02	0,025	0,015
100	10	14	18	40	40	75	50	80	-	0,02	0,025	0,015
125	18	25	30	60	50	100	62	100	120	0,03	0,035	0,02
160	18	30	40	60	50	135	88	100	150	0,03	0,035	0,02
200	30	40	53	80	80	162	96	160	185	0,04	0,045	0,025
250	30	53	75	80	80	200	150	160	225	0,04	0,045	0,025
315	53	75	100	120	125	252	210	250	300	0,05	0,055	0,03
400	53	100	125	120	125	282	250	250	350	0,06	0,065	0,03
500	75	100	125	160	200	282	300	400	400	0,10	0,10	0,05
630	75	125	160	160	200	325	400	400	400	0,10	0,10	0,05
800	160	200	250	160	300	500	400	500	500	0,11	0,11	0,06

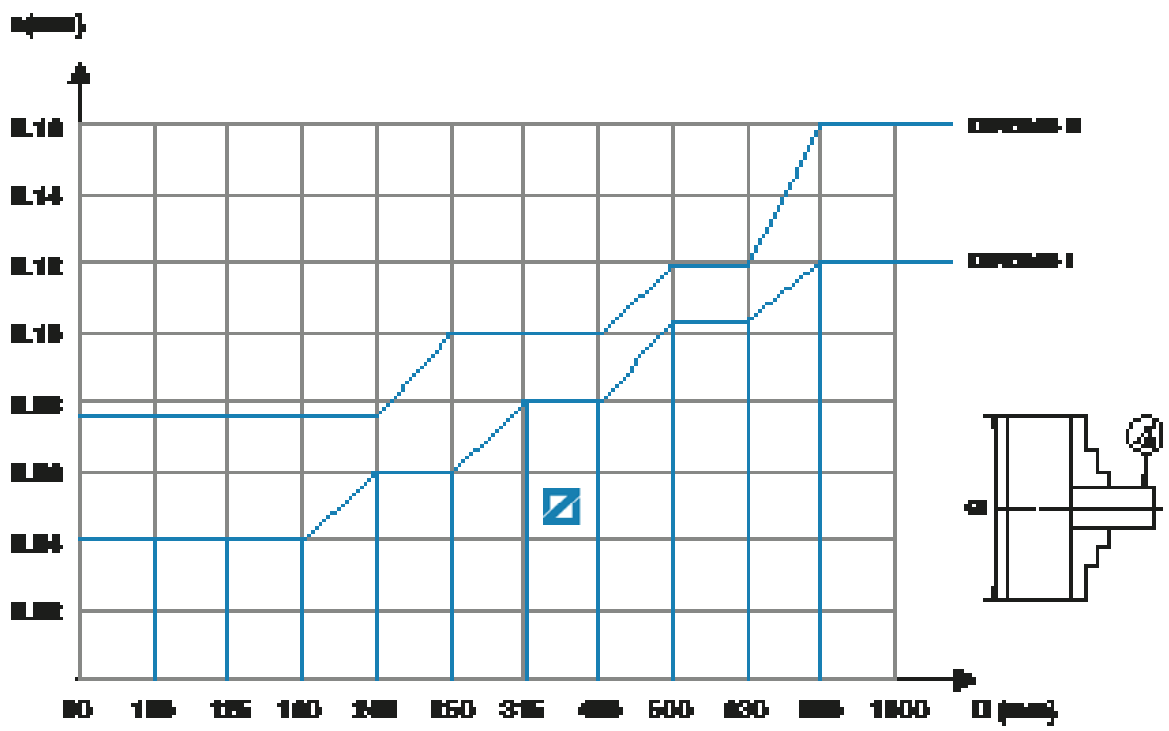

Die Rundlauf-Genauigkeit unserer ZENTRA-Planspiral-Drehfutter entspricht DIN Klasse 1 oder besser
The concentricity of our ZENTRA lathe chucks is according to DIN class 1 or better



Technische Daten

Technical data

Werkstückparameter / Work piece parameters

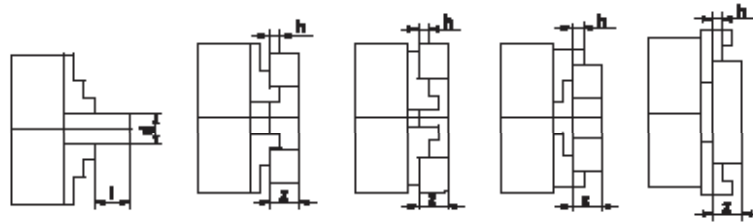

Ø	80	100	125	160	200	250	315	400	500	630	800
l	1,2 x d	1,2 x d	1,2 x d	1,2 x d	1,2 x d	1,2 x d	1,5 x d	1,5 x d	1,5 x d	1,0 x d	1,0 x d
z	4 x h	4 x h	4 x h	4 x h	4 x h	4 x h	4 x h	4 x h	4 x h	4 x h	4 x h

Maximale Spannkraft / Total gripping force

Ø	80	100	125	160	200	250	315	400	500	630	800
daN	1000	1700	2400	3100	3700	4600	5500	6500	7200	8000	9000

Maximales Anzugsmoment / Maximum torque

Ø	80	100	125	160	200	250	315	400	500	630	800
Nm	35	50	75	120	160	180	200	280	360	460	500

Maximale Drehzahlen (min⁻¹) / Maximum speed (min⁻¹)

Ø	80	100	125	160	200	250	315	400	500	630	800
Drehfutter Guss / Lathe chucks cast iron	4000	3500	3200	3000	2500	2000	1500	1000	700	500	300
Drehfutter Stahl / Lathe chucks steel	6000	5200	4800	4500	4000	3500	2800	2000	1200	1000	450
Planscheiben / Independent chucks	3000	3000	2500	2000	1800	1500	1200	800	500	400	300

Unwucht (Stahl-Drehfutter) / Unbalance (steel body lathe chucks)

Ø	80	100	125	160	200	250	315	400	500	630	800
gcm	11	16	23	32	45	63	90	140	300	640	-

Spannbereich / Clamping range

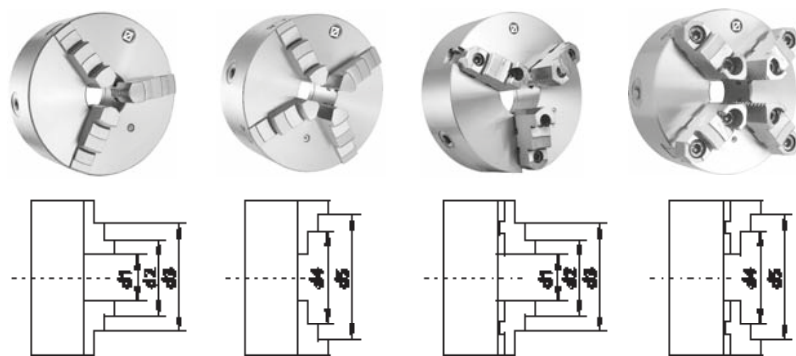

Ø	d1		d2		d3 max.		d4 max.		d5 max.	
mm	solid	reversible	solid	reversible	solid	reversible	solid	reversible	solid	reversible
80	2-27	-	22-46	-	45-69	-	25-50	-	48-71	-
100	3-33	-	25-56	-	56-87	-	32-62	-	62-83	-
125	3-50	3-50	34-74	34-76	72-115	75-118	39-83	52-96	80-125	95-125
160	4-64	3-64	42-100	42-97	94-154	88-146	50-107	62-121	98-160	115-160
200	4-90	4-90	52-135	50-130	120-202	105-190	60-145	72-156	130-200	133-200
250	5-118	5-118	62-174	58-165	145-256	125-235	77-188	86-197	160-250	160-250
315	10-131	10-131	78-200	65-182	172-299	145-265	90-215	103-226	190-315	190-315
400	10-180	10-180	85-252	72-228	210-380	165-329	103-272	127-294	230-400	230-400
500	20-235	20-235	120-335	120-410	245-476	200-485	140-357	110-400	276-500	190-500
630	30-335	30-335	160-465	140-590	325-630	210-665	180-487	120-570	345-630	200-630
800	150-482	150-482	282-614	252-736	448-780	328-812	302-634	240-724	468-800	316-800

Planspiral-Drehfutter Lathe chucks

- Geeignet für Drehmaschinen sowie alle Arten von Fräs- und Bohrvorrichtungen
 - Lieferung mit je einem Satz Dreh- und Bohrbacken oder Grund- und Aufsatzbacken
 - Zylindrisch oder mit Direktaufnahme
 - Futterkörper aus Guss oder Stahl
 - Führungen und Verschleißflächen geschliffen
 - Planspiralring aus hochwertigem Legierungsstahl gesenkgeschmiedet und gehärtet
- suitable for all types of lathes and different kinds of milling, drilling and CNC devices
 - incl. one set of hard solid outside and inside jaws or two-piece hard reversible jaws
 - available with plain back and direct mounting
 - chuck body made from cast iron or steel
 - guide ways and wear surfaces ground
 - scroll plate is drop forged of fine-alloy steel and case hardened

Zweibacken-Drehfutter Two-jaw lathe chucks

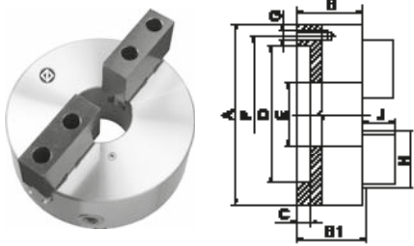

Zylindrische Aufnahme nach DIN 6350, geteilte Backen Centre mount according to DIN 6350, two-piece jaws

Diese Drehfutter sind besonders geeignet zur Aufnahme von Mehrkant- oder Formdrehelementen, die in Drei- oder Vierbackenfuttern nicht zu spannen sind.

Especially suitable for holding multicornered and form turned elements, which cannot be clamped by 3- or 4-jaw lathe chucks.

Guss / Cast iron

A (∅) mm	B mm	B1 mm	C mm	D mm	E mm	F mm	G mm	H mm	J mm	RPM _{MAX} min-1	kg	Art.-Nr. / Order no.
160	64	69,3	4	125	42	140	6xM10	67	43	3000	10	ZE-6252-160
200	75	79,8	4	160	55	176	6xM10	80	45	2500	17,5	ZE-6252-200
250	85	88,8	5	200	76	224	6xM12	95	53	2000	29	ZE-6252-250
315	94	99,1	5	260	103	286	6xM16	110	57	1500	50	ZE-6252-315
400	105	113,8	5	330	136	362	6xM16	127	67	1000	85	ZE-6252-400

Inkl. je 1 Satz Grundbacken und weichen Umkehraufsatzbacken, Spanschlüssel, Befestigungsschrauben
Incl. 1 set base jaws and soft reversible top jaws, wrench, fixing screws

Dreibacken-Drehfutter Three-jaw lathe chucks

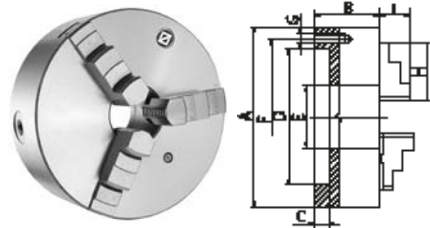

Zylindrische Aufnahme nach DIN 6350, einteilige Backen Cylindrical mount according to DIN 6350, one-piece jaws

Diese Drehfutter gewährleisten eine gleichmäßige Spannkraft durch zentrisch anliegende Backen sowie eine hohe Rundlaufgenauigkeit.

These lathe chucks guarantee a homogeneous clamping force by self-centering clamping jaws as well as a high concentricity.

Guss / Cast iron

A (∅) mm	B mm	C mm	D mm	E mm	F mm	G mm	H mm	J mm	RPM _{MAX} min ⁻¹	kg	Art.-Nr. / Order no.
80	44	3	56	16	67	3xM6	32	13	4000	1,5	● ZE-6353-080
100	50	3	70	20	83	3xM8	42	17	3500	2,8	● ZE-6353-100
125	56	4	95	32	108	3xM8	51	20	3200	5	● ZE-6353-125
160	64	4	125	42	140	6xM10	70	32	3000	10	● ZE-6353-160
200	75	4	160	55	176	6xM10	85	29	2500	16,6	● ZE-6353-200
250	85	5	200	76	224	6xM12	105	34	2000	29	● ZE-6353-250
315	94	5	260	103	286	6xM16	125	43	1500	50	● ZE-6353-315
400	105	5	330	136	362	6xM16	145	55	1000	85	● ZE-6353-400
500	120	5	420	190	458	6xM16	180	60	700	145	● ZE-6353-500
630	135	7	545	252	586	6xM16	225	70	500	250	● ZE-6353-630
800	159	20	450	320	368,3	-	225	70	300	402	● ZE-6353-800

Stahl / Steel

A (∅) mm	B mm	C mm	D mm	E mm	F mm	G mm	H mm	J mm	RPM _{MAX} min ⁻¹	kg	Art.-Nr. / Order no.
80	44	3	56	16	67	3xM6	32	13	6000	1,5	● ZE-8353-080
100	50	3	70	20	83	3xM8	42	17	5200	2,8	● ZE-8353-100
125	59,5	4	95	35,5	108	3xM8	51	20	4800	5	● ZE-8353-125
160	68	4	125	42	140	6xM10	70	32	4500	10	● ZE-8353-160
200	78	4	160	55	176	6xM10	85	29	4000	17,5	● ZE-8353-200
250	89	5	200	76	224	6xM12	105	34	3500	29	● ZE-8353-250
315	96,2	5	260	103	286	6xM16	125	43	2800	50	● ZE-8353-315
400	108	5	330	136	362	6xM16	145	55	2000	85	● ZE-8353-400
500	119	5	420	190	458	6xM16	180	60	1200	145	● ZE-8353-500
630	129	7	545	252	586	6xM16	225	70	1000	250	● ZE-8353-630
800	150	20	450	320	368,3	-	225	70	450	402	○ ZE-8353-800

Inkl. je 1 Satz Dreh- und Bohrbacken, Spannschlüssel, Befestigungsschrauben
Incl. 1 set each of solid jaws internally / externally stepped, wrench, fixing screws



Dreibacken-Drehfutter Three-jaw lathe chucks

1
1.1

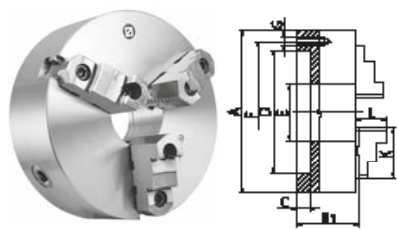

Zylindrische Aufnahme nach DIN 6350, geteilte Backen Centre mount according to DIN 6350, two-piece jaws

Guss / Cast iron

A (Ø) mm	B1 mm	C mm	D mm	E mm	F mm	G mm	H mm	J mm	RPM _{MAX} min ⁻¹	kg	Art.-Nr. / Order no.
125	60,8	4	95	32	108	3xM8	56	40	3200	5	● ZE-6363-125
160	69,3	4	125	42	140	6xM10	67	43	3000	10	● ZE-6363-160
200	79,8	4	160	55	176	6xM10	80	45	2500	17,5	● ZE-6363-200
250	88,8	5	200	76	224	6xM12	95	53	2000	29	● ZE-6363-250
315	99,1	5	260	103	286	6xM16	110	57	1500	50	● ZE-6363-315
400	113,8	5	330	136	362	6xM16	127	67	1000	85	● ZE-6363-400
500	130,8	5	420	190	458	6xM16	127	79	700	145	● ZE-6363-500
630	146,3	7	545	252	586	6xM16	127	87	500	250	● ZE-6363-630
800	170,3	20	450	320	368,3	-	127	87	300	402	○ ZE-6363-800

Stahl / Steel

125	66,3	4	95	35,5	108	3xM8	56	40	4800	5	● ZE-8363-125
160	72,8	4	125	42	140	6xM10	67	43	4500	10	● ZE-8363-160
200	82,8	4	160	55	176	6xM10	80	45	4000	17,5	● ZE-8363-200
250	92,8	5	200	76	224	6xM12	95	53	3500	29	● ZE-8363-250
315	101,3	5	260	103	286	6xM16	110	57	2800	50	● ZE-8363-315
400	116,8	5	330	136	362	6xM16	127	67	2000	85	● ZE-8363-400
500	129,8	5	420	190	458	6xM16	127	79	1200	145	● ZE-8363-500
630	140,3	7	545	252	586	6xM16	127	87	1000	250	● ZE-8363-630
800	161,3	20	450	320	368,3	-	127	87	450	402	○ ZE-8363-800

Inkl. je 1 Satz gehärteter Grund- und Umkehraufsatzbacken, Spannschlüssel, Befestigungsschrauben
Incl. 1 set each of hardened base jaws and reversible top jaws, wrench, fixing screws

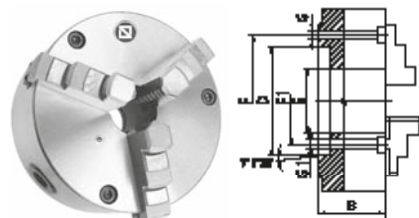

Kurzkegelaufnahme nach DIN 55026, einteilige Backen According to DIN 55026, one-piece jaws

Stahl / Steel

Ø mm	KK Taper	Typ / Type	B mm	D mm	E mm	F mm	F1 mm	G mm	G1 mm	RPM _{MAX} min ⁻¹	kg	Art.-Nr. / Order no.
160	5	A1	68	82,6	42	-	62	-	M10	4500	10	● ZE-8356-165
200	5	A1	78	82,6	42	-	62	-	M10	4000	19	● ZE-8356-205
200	6	A1	78	106,4	55	-	82	-	M12	4000	19	● ZE-8356-206
250	5	A2	89	82,6	76	104,8	-	M10	-	3500	32	● ZE-8356-255
250	6	A1	89	106,4	55	-	82	-	M12	3500	32	● ZE-8356-256
250	8	A1	89	139,7	76	-	111	-	M16	3500	32	● ZE-8356-258
315	6	A2	96,2	106,4	103	133,4	-	M12	-	2800	55	● ZE-8356-316
315	8	A1	96,2	139,7	80	-	111	-	M16	2800	55	● ZE-8356-318
400	8	A2	108	139,7	136	171,4	-	M16	-	2000	92	● ZE-8356-408
400	11	A1	108	196,9	130	-	165	-	M20	2000	92	● ZE-8356-411

Inkl. je 1 Satz Dreh- und Bohrbacken, Spannschlüssel, Befestigungsschrauben
Incl. 1 set each of solid jaws internally / externally stepped, wrench, fixing bolts

Dreibacken-Drehfutter Three-jaw lathe chucks

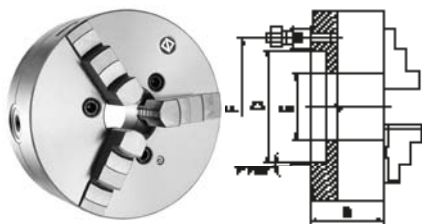

Kurzkegelaufnahme nach DIN 55027, einteilige Backen According to DIN 55027, one-piece jaws

Stahl / Steel

Ø mm	KK Taper	B mm	D mm	E mm	F mm	RPM _{MAX} min ⁻¹	kg	Art.-Nr. / Order no.
125	3	59,5	54	35,5	75	4800	5	ZE-8357-123
125	4	59,5	63,5	35,5	85	4800	5	ZE-8357-124
160	4	68	63,5	42	85	4500	9	ZE-8357-164
160	5	68	82,6	42	104,8	4500	9	ZE-8357-165
200	4	78	63,5	55	85	4000	19	ZE-8357-204
200	5	78	82,6	55	104,8	4000	19	ZE-8357-205
200	6	78	106,4	55	133,4	4000	19	ZE-8357-206
250	6	89	106,4	76	133,4	3500	32	ZE-8357-256
250	8	89	139,7	76	171,4	3500	32	ZE-8357-258
315	6	96,2	106,4	103	133,4	2800	51	ZE-8357-316
315	8	96,2	139,7	103	171,4	2800	51	ZE-8357-318
315	11	117,7	196,9	103	235	2800	51	ZE-8357-311
400	8	108	139,7	136	171,4	2000	101	ZE-8357-408
400	11	108	196,9	136	235	2000	101	ZE-8357-411

Inkl. je 1 Satz Dreh- und Bohrbacken, Spanschlüssel, Befestigungsbolzen
Incl. 1 set each of solid jaws internally / externally stepped, wrench, fixing bolts

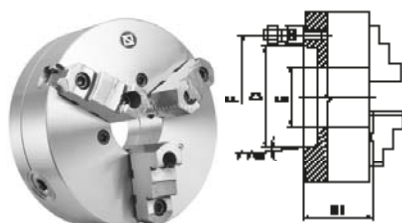

Kurzkegelaufnahme nach DIN 55027, geteilte Backen According to DIN 55027, two-piece jaws

Stahl / Steel

Ø mm	KK Taper	B1 mm	D mm	E mm	F mm	RPM _{MAX} min ⁻¹	kg	Art.-Nr. / Order no.
125	3	64,8	54	35,5	75	4800	5	ZE-8367-123
125	4	64,8	63,5	35,5	85	4800	5	ZE-8367-124
160	4	72,8	63,5	42	85	4500	9	ZE-8367-164
160	5	72,8	82,6	42	104,8	4500	9	ZE-8367-165
200	5	82,8	82,6	55	104,8	4000	19	ZE-8367-205
200	6	82,8	106,4	55	133,4	4000	19	ZE-8367-206
250	6	92,8	106,4	76	133,4	3500	32	ZE-8367-256
250	8	92,8	139,7	76	171,4	3500	32	ZE-8367-258
315	6	101,3	106,4	103	133,4	2800	51	ZE-8367-316
315	8	101,3	139,7	103	171,4	2800	51	ZE-8367-318
400	8	116,8	139,7	136	171,4	2000	101	ZE-8367-408
400	11	116,8	196,9	136	235	2000	101	ZE-8367-411

Inkl. je 1 Satz gehärteter Grund- und Umkehrsaufsatzbacken, Spanschlüssel, Befestigungsbolzen
Incl. 1 set each of hardened base jaws and reversible top jaws, wrench, fixing bolts



Dreibacken-Drehfutter Three-jaw lathe chucks

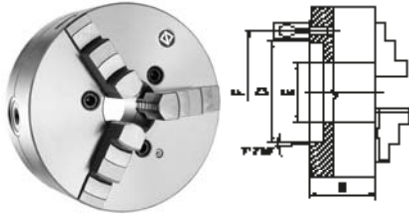

Kurzkegelaufnahme DIN 55029 (Camlock), einteilige Backen According to DIN 55029 (Camlock), one-piece jaws

Stahl / Steel

Ø mm	KK Taper	B mm	D mm	E mm	F mm	RPM _{MAX} min-1	kg	Art.-Nr. / Order no.
125	3	59,5	54	35,5	70,6	4800	5	ZE-8359-123
125	4	59,5	63,5	35,5	82,6	4800	5	ZE-8359-124
160	3	68	54	42	70,6	4500	9	ZE-8359-163
160	4	68	63,5	42	82,6	4500	9	ZE-8359-164
160	5	68	82,6	42	104,8	4500	9	ZE-8359-165
200	4	78	63,5	55	82,6	4000	19	ZE-8359-204
200	5	78	82,6	55	104,8	4000	19	ZE-8359-205
200	6	78	106,4	55	133,4	4000	19	ZE-8359-206
250	6	89	106,4	76	133,4	3500	32	ZE-8359-256
250	8	89	139,7	76	171,4	3500	32	ZE-8359-258
315	6	96,2	106,4	103	133,4	2800	51	ZE-8359-316
315	8	96,2	139,7	103	171,4	2800	51	ZE-8359-318
315	11	140	196,9	103	235	2800	51	ZE-8359-311
400	8	108	139,7	136	171,4	2000	101	ZE-8359-408
400	11	108	196,9	136	235	2000	101	ZE-8359-411

Inkl. je 1 Satz Dreh- und Bohrbacken, Spanschlüssel, Befestigungsbolzen
Incl. 1 set each of solid jaws internally / externally stepped, wrench, fixing bolts

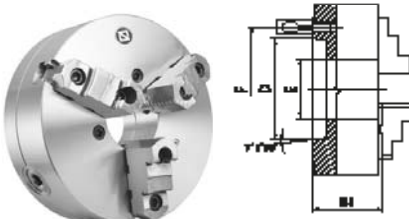

Kurzkegelaufnahme DIN 55029 (Camlock), geteilte Backen According to DIN 55029 (Camlock), two-piece jaws

Stahl / Steel

Ø mm	KK Taper	B1 mm	D mm	E mm	F mm	RPM _{MAX} min-1	kg	Art.-Nr. / Order no.
125	3	64,8	54	35,5	70,6	4800	5	ZE-8369-123
125	4	64,8	63,5	35,5	82,6	4800	5	ZE-8369-124
160	3	72,8	54	42	70,6	4500	9	ZE-8369-163
160	4	72,8	63,5	42	82,6	4500	9	ZE-8369-164
160	5	72,8	82,6	42	104,8	4500	9	ZE-8369-165
200	4	82,8	63,5	55	82,6	4000	19	ZE-8369-204
200	5	82,8	82,6	55	104,8	4000	19	ZE-8369-205
200	6	82,8	106,4	55	133,4	4000	19	ZE-8369-206
250	6	92,8	106,4	76	133,4	3500	32	ZE-8369-256
250	8	92,8	139,7	76	171,4	3500	32	ZE-8369-258
315	6	101,3	106,4	103	133,4	2800	51	ZE-8369-316
315	8	101,3	139,7	103	171,4	2800	51	ZE-8369-318
315	11	145	196,9	103	235	2800	51	ZE-8369-311
400	8	116,8	139,7	136	171,4	2000	101	ZE-8369-408
400	11	116,8	196,9	136	235	2000	101	ZE-8369-411

Inkl. je 1 Satz gehärteter Grund- und Umkehrsaufsatzbacken, Spanschlüssel, Befestigungsbolzen
Incl. 1 set each of hardened base jaws and reversible top jaws, wrench, fixing bolts

Vierbacken-Drehfutter Four-jaw lathe chucks

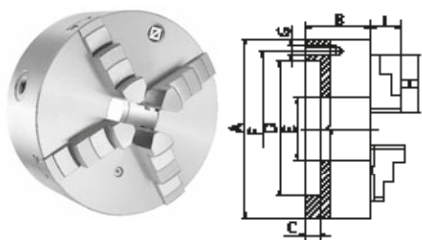

Zylindrische Aufnahme nach DIN 6350, einteilige Backen Centre mount according to DIN 6350, one-piece jaws

Diese Drehfutter gewährleisten eine gleichmäßige Spannkraft durch zentrisch spannende Backen sowie eine hohe Rundlaufgenauigkeit.

These lathe chucks guarantee a homogeneous clamping force by self-centering clamping jaws as well as a high concentricity.

Guss / Cast iron

A (∅) mm	B mm	C mm	D mm	E mm	F mm	G mm	H mm	J mm	RPM _{MAX} min-1	kg	Art.-Nr. / Order no.
100	50	3	70	20	83	3xM8	42	17	3500	2,8	● ZE-6454-100
125	56	4	95	32	108	3xM8	51	20	3200	5	● ZE-6454-125
160	64	4	125	42	140	6xM10	70	32	3000	10	● ZE-6454-160
200	75	4	160	55	176	6xM10	85	29	2500	17,5	● ZE-6454-200
250	85	5	200	76	224	6xM12	105	34	2000	29	● ZE-6454-250
315	94	5	260	103	286	6xM16	125	43	1500	50	● ZE-6454-315
400	105	5	330	136	362	6xM16	145	55	1000	85	● ZE-6454-400
500	120	5	420	190	458	6xM16	180	60	700	145	● ZE-6454-500
630	135	7	545	252	586	6xM16	225	70	500	250	● ZE-6454-630
800	159	20	450	320	368,3	-	225	70	300	402	○ ZE-6454-800

Inkl. je 1 Satz Dreh- und Bohrbacken, Spannschlüssel, Befestigungsschrauben
Incl. 1 set each of solid jaws internally / externally stepped, wrench, fixing screws

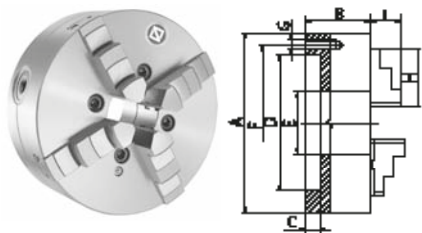

Stahl / Steel

A (∅) mm	B mm	C mm	D mm	E mm	F mm	G mm	H mm	J mm	RPM _{MAX} min-1	kg	Art.-Nr. / Order no.
100	50	3	70	20	83	3xM8	42	17	5200	2,8	● ZE-8454-100
125	59,5	4	95	35,5	108	3xM8	51	20	4800	5	● ZE-8454-125
160	68	4	125	42	140	6xM10	70	32	4500	10	● ZE-8454-160
200	78	4	160	55	176	6xM10	85	29	4000	17,5	● ZE-8454-200
250	89	5	200	76	224	6xM12	105	34	3500	29	● ZE-8454-250
315	96,2	5	260	103	286	6xM16	125	43	2800	50	● ZE-8454-315
400	108	5	330	136	362	6xM16	145	55	2000	85	● ZE-8454-400
500	119	5	420	190	458	6xM16	180	60	1200	145	● ZE-8454-500
630	129	7	545	252	586	6xM16	225	70	1000	250	○ ZE-8454-630
800	159	20	450	320	368,3	-	225	70	450	402	○ ZE-8454-800

Inkl. je 1 Satz Dreh- und Bohrbacken, Spannschlüssel, Befestigungsschrauben
Incl. 1 set each of solid jaws internally / externally stepped, wrench, fixing screws



Vierbacken-Drehfutter Four-jaw lathe chucks

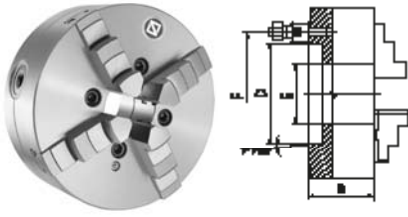

Kurzkegelaufnahme nach DIN 5027, einteilige Backen According to DIN 5027, one-piece jaws

Stahl / Steel

Ø mm	KK Taper	B mm	D mm	E mm	F mm	RPM _{MAX} min-1	kg	Art.-Nr. / Order no.
125	3	59,5	54	35,5	75	4800	5	ZE-8457-123
125	4	59,5	63,5	35,5	85	4800	5	ZE-8457-124
160	4	68	63,5	42	85	4500	9	ZE-8457-164
160	5	68	82,6	42	104,8	4500	9	ZE-8457-165
200	4	78	63,5	55	85	4000	19	ZE-8457-204
200	5	78	82,6	55	104,8	4000	19	ZE-8457-205
200	6	78	106,4	55	133,4	4000	19	ZE-8457-206
250	6	89	106,4	76	133,4	3500	32	ZE-8457-256
250	8	89	139,7	76	171,4	3500	32	ZE-8457-258
315	6	96,2	106,4	103	133,4	2800	51	ZE-8457-316
315	8	96,2	139,7	103	171,4	2800	51	ZE-8457-318
315	11	96,2	196,9	103	235	2800	51	ZE-8457-311
400	8	108	139,7	136	171,4	2000	101	ZE-8457-408
400	11	108	196,9	136	235	2000	101	ZE-8457-411

Inkl. je 1 Satz Dreh- und Bohrbacken, Spanschlüssel, Befestigungsbolzen
Incl. 1 set each of solid jaws internally / externally stepped, wrench, fixing screws

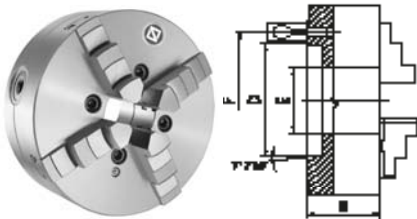

Kurzkegelaufn. nach DIN 5029 (Camlock), einteilige Backen According to DIN 5029 (Camlock), one-piece jaws

Stahl / Steel

Ø mm	KK Taper	B mm	D mm	E mm	F mm	RPM _{MAX} min-1	kg	Art.-Nr. / Order no.
125	3	59,5	54	35,5	70,6	4800	5	ZE-8459-123
125	4	59,5	63,5	35,5	82,6	4800	5	ZE-8459-124
160	4	68	63,5	42	82,6	4500	9	ZE-8459-164
160	5	68	82,6	42	104,8	4500	9	ZE-8459-165
200	4	78	63,5	55	82,6	4000	19	ZE-8459-204
200	5	78	82,6	55	104,8	4000	19	ZE-8459-205
200	6	78	106,4	55	133,4	4000	19	ZE-8459-206
250	6	89	106,4	76	133,4	3500	32	ZE-8459-256
250	8	89	139,7	76	171,4	3500	32	ZE-8459-258
315	6	96,2	106,4	103	133,4	2800	51	ZE-8459-316
315	8	96,2	139,7	103	171,4	2800	51	ZE-8459-318
400	8	108	139,7	136	171,4	2000	101	ZE-8459-408
400	11	108	196,9	136	235	2000	101	ZE-8459-411

Inkl. je 1 Satz Dreh- und Bohrbacken, Spanschlüssel, Befestigungsbolzen
Incl. 1 set each of solid jaws internally / externally stepped, wrench, fixing screws

Drehfutter mit radialer Feineinstellung

Lathe chucks with radial fine adjustment

Drehfutter mit radialer Feineinstellung gewährleisten eine sehr hohe Rundlaufgenauigkeit.

- Einstellgenauigkeit 0,005 mm
- Wiederholgenauigkeit 0,015 mm

Radial fine adjustment provides high concentricity.

- adjusting accuracy within 0,005 mm
- repeatability 0,015 mm

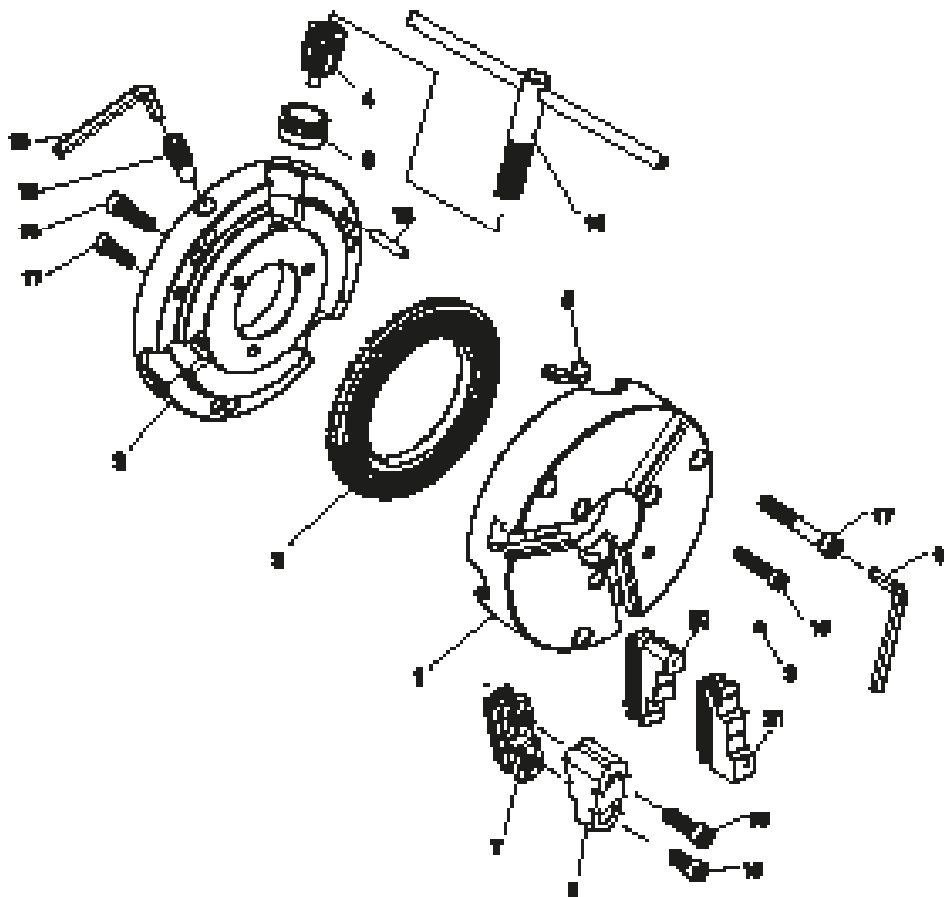

- | | |
|--------------------------|------------------------------------|
| 1. Futterkörper | 1. Chuck body |
| 2. Futterdeckel | 2. Back cover |
| 3. Planspirale | 3. Scroll plate |
| 4. Ritzel | 4. Pinion |
| 5. Halbscheibe | 5. Pinion half ring |
| 6. Führungsbuchse | 6. Pinion sleeve |
| 7. Grundbacke, hart | 7. Hard master jaw |
| 8. Aufsatzbacke, hart | 8. Hard top jaw |
| 9. Schmiernippel | 9. Grease nipple |
| 10. Verschlusschraube | 10. Back cover mounting bolt |
| 11. Verschlusschraube | 11. Back cover mounting bolt |
| 12. Passstift | 12. Spindle locating pin |
| 13. Verschlusschraube | 13. Back cover mounting bolt |
| 14. Schlüssel | 14. Chuck wrench |
| 15. Schrauben für Backe | 15. Hard top jaw mounting bolt |
| 16. Schrauben für Backe | 16. Hard top jaw mounting bolt |
| 17. Befestigungsschraube | 17. Chuck mounting bolt |
| 18. Sechskant-Schlüssel | 18. Hexagonal keys |
| 19. Einstellschraube | 19. Fine adjustment screw |
| 20. Bohrbacke | 20. Hard solid outside stepped jaw |
| 21. Drehbacke | 21. Hard solid inside stepped jaw |

Dreibacken-Drehfutter mit Feineinstellung

Three-jaw lathe chucks with fine adjustment



Stahl / Steel

mit radialer
Feineinstellung
Geeignet für die Aufnahme
von vorne
with fine adjustment
Suitable for admission
from the front

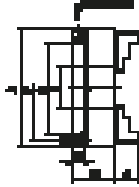

Dreibacken-Drehfutter mit radialer Feineinstellung, einteilige Backen

Three-jaw lathe chucks with radial fine adjustment, one-piece jaws

A (∅) mm	C mm	D mm	E mm	F mm	B mm	J mm	RPM _{MAX} min ⁻¹	Art.-Nr. / Order no.
125	15	55	35,5	108	71,5	20	3800	● ZE-8353-125FE
160	18	86	42	140	68	32	3500	● ZE-8353-160FE
200	20	110	55	176	78	29	3100	● ZE-8353-200FE
250	20	145	76	224	89	34	2700	● ZE-8353-250FE
315	20	180	103	286	96,2	43	2200	● ZE-8353-315FE
400	22	299,2	136	171,5	123	55	1800	● ZE-8353-400FE

Inkl. je 1 Satz Dreh- und Bohrbacken, Spannschlüssel, Befestigungsschrauben
Incl. 1 set each of solid jaws internally / externally stepped, wrench, fixing screws



Stahl / Steel

mit radialer
Feineinstellung
Geeignet für die Aufnahme
von vorne
with fine adjustment
Suitable for admission
from the front

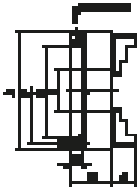

Dreibacken-Drehfutter mit radialer Feineinstellung, geteilte Backen

Three-jaw lathe chucks with radial fine adjustment, two-piece jaws

A (∅) mm	C mm	D mm	E mm	F mm	B mm	J mm	RPM _{MAX} min ⁻¹	Art.-Nr. / Order no.
125	15	55	35,5	108	71,5	40	3800	● ZE-8363-125FE
160	18	86	42	140	68	43	3500	● ZE-8363-160FE
200	20	110	55	176	78	45	3100	● ZE-8363-200FE
250	20	145	76	224	89	53	2700	● ZE-8363-250FE
315	20	180	103	286	96,2	57	2200	○ ZE-8363-315FE
400	22	299,2	136	171,5	123	67	1800	○ ZE-8363-400FE

Inkl. je 1 Satz gehärteter Grund- und Umkehrsaufsatzbacken, Spannschlüssel, Befestigungsschrauben
Incl. 1 set each of hardened base jaws and reversible top jaws, wrench, fixing screws

Achtung: Spezialflansche für diese Futter auf Anfrage
Attention: Special adaptor plates available upon request

Sechsbanken-Drehfutter mit Feineinstellung

Six-jaw lathe chucks with fine adjustment

Die Drehfutter mit radialer Feineinstellung sind besonders geeignet zum Spannen von dünnwandigen Rohren und weichen Materialien.

These lathe chucks with radial fine adjustment are especially suitable for holding thin-sided tubes and soft materials.

- Einstellgenauigkeit 0,005 mm
- Wiederholgenauigkeit 0,015 mm

- adjusting accuracy within 0,005 mm
- repeatability 0,015 mm

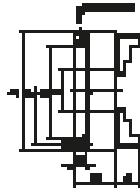

Sechsbanken-Drehfutter mit radialer Feineinstellung, einteilige Backen

Six-jaw lathe chucks with radial fine adjustment, one-piece jaws

A (∅) mm	C mm	D mm	E mm	F mm	B mm	H mm	RPM _{MAX} min-1	Art.-Nr. / Order no.
125	15	55	35,5	108	71,5	20	3000	ZE-8653-125
160	18	86	42	140	68	32	2500	ZE-8653-160
200	20	110	55	176	78	29	2200	ZE-8653-200
250	20	145	76	224	89	34	1900	ZE-8653-250
315	20	180	103	286	96,2	43	1500	ZE-8653-315
400	22	299,2	136	171,5	123	55	1300	ZE-8653-400

Inkl. je 1 Satz Dreh- und Bohrbacken, Spanschlüssel, Befestigungsschrauben
Incl. 1 set each of solid jaws internally / externally stepped, wrench, fixing screws

Stahl / Steel

mit radialer Feineinstellung
Geeignet für die Aufnahme von vorne
with fine adjustment
Suitable for admission from the front

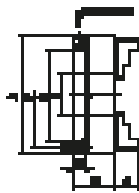

Sechsbanken-Drehfutter mit radialer Feineinstellung, geteilte Backen

Six-jaw lathe chucks with radial fine adjustment, two-piece jaws

A (∅) mm	C mm	D mm	E mm	F mm	B mm	H mm	RPM _{MAX} min-1	Art.-Nr. / Order no.
125	15	55	35,5	108	71,5	40	3000	ZE-8663-125
160	18	86	42	140	68	43	2500	ZE-8663-160
200	20	110	55	176	78	45	2200	ZE-8663-200
250	20	145	76	224	89	53	1900	ZE-8663-250
315	20	180	103	286	96,2	57	1500	ZE-8663-315
400	22	299,2	136	171,5	123	67	1300	ZE-8663-400
500	30	407,7	190	235	144	79	800	ZE-8663-500
630	30	407,1	252	330,2	150	87	700	ZE-8663-630

Inkl. je 1 Satz gehärteter Grund- und Umkehrsaufsatzbacken, Spanschlüssel, Befestigungsschrauben
Incl. 1 set each of hardened base jaws and reversible top jaws, wrench, fixing screws

Stahl / Steel

mit radialer Feineinstellung
Geeignet für die Aufnahme von vorne
with fine adjustment
Suitable for admission from the front

Achtung: Spezialflansche für diese Futter auf Anfrage
Attention: Special adaptor plates available upon request



Dreibacken-Drehfutter mit großer Bohrung

Three-jaw chucks with large through-hole



Zylindrische Aufnahme, geteilte Backen

Centre mount, two-piece jaws

Drehfutter mit großer Durchgangsbohrung für Rohrbearbeitung. Auch geeignet für den Einsatz auf Drehmaschinen, Rundtischen und Schweißvorrichtungen.

Large through-hole chucks are designed for pipe machining or welding/cut off operations. They can also be used on lathes, rotary tables and welding devices.

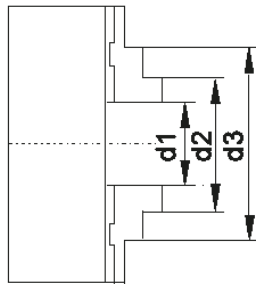
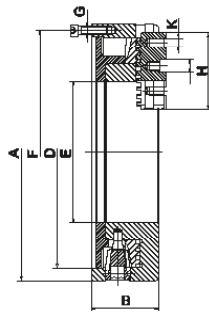

Spannbereich / Clamping range

Ø mm	d1 mm		d2 mm		d3 mm	
	Min.	Max.	Min.	Max.	Min.	Max.
400	130	270	230	350	300	400
508	250	380	330	450	385	500
660	376	470	455	575	515	635
800	260	566	360	750	420	800

Stahl / Steel

A (Ø) mm	H mm	B mm	K mm	D mm	E mm	F mm	G mm	RPM _{MAX} min-1	Art.-Nr. / Order no.
400	120	105	5/8"-11	362	220	381	M12x40	650	ZE-3595-400
508	120	120	3/4"-10	462	320	481,5	M16x40	460	ZE-3595-508
660	127	135	3/4"-10	580	406	620	M16x40	325	ZE-3595-660
800	225	151	3/4"-10	710	410	460	M24X160	260	ZE-3595-800

Inkl. je 1 Satz gehärteter Grund- und Umkehraufsatzbacken, Spannschlüssel, Befestigungsschrauben
Incl. 1 set each of hardened base jaws and reversible top jaws, wrench, fixing screws

Ersatzbacken auf Anfrage lieferbar
Spare jaws available upon request

Backensätze für Planspiral-Drehfutter Jaws for lathe chucks

Drehbacken für Planspiral-Drehfutter (nach innen abgestuft) Internally stepped solid jaws for lathe chucks

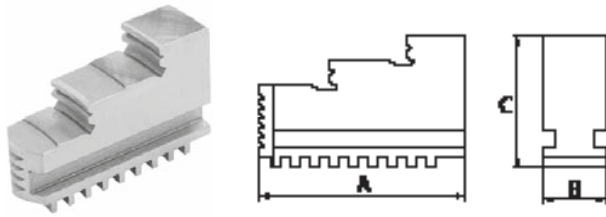

Für / for Ø mm	A mm	B mm	C mm	3-Ba. / 3-Jaw Art.-Nr. / Order no.	4-Ba. / 4-Jaw Art.-Nr. / Order no.	6-Ba. / 6-Jaw Art.-Nr. / Order no.
80	32	11	28	● ZE-DB35-080	-	-
100	42	15	32	● ZE-DB35-100	● ZE-DB36-100	-
125	51	20	40	● ZE-DB35-125	● ZE-DB36-125	○ ZE-DB38-125
160	70	20	53	● ZE-DB35-160	● ZE-DB36-160	○ ZE-DB38-160
200	85	25	54	● ZE-DB35-200	● ZE-DB36-200	○ ZE-DB38-200
250	105	28	63	● ZE-DB35-250	● ZE-DB36-250	○ ZE-DB38-250
315	125	32	73	● ZE-DB35-315	● ZE-DB36-315	○ ZE-DB38-315
400	145	36	92	● ZE-DB35-400	● ZE-DB36-400	○ ZE-DB38-400
500	180	40	100	● ZE-DB35-500	● ZE-DB36-500	-
630/800	225	50	110	● ZE-DB35-630/800	● ZE-DB36-630/800	-

Preis pro Satz / Price per set

Bohrbacken für Planspiral-Drehfutter (nach außen abgestuft) Externally stepped solid jaws for lathe chucks

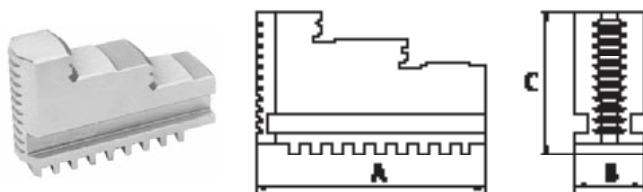

Für / for Ø mm	A mm	B mm	C mm	3-Ba. / 3-Jaw Art.-Nr. / Order no.	4-Ba. / 4-Jaw Art.-Nr. / Order no.	6-Ba. / 6-Jaw Art.-Nr. / Order no.
80	32	11	28	● ZE-BB35-080	-	-
100	42	15	32	● ZE-BB35-100	● ZE-BB36-100	-
125	51	20	40	● ZE-BB35-125	● ZE-BB36-125	○ ZE-BB38-125
160	70	20	53	● ZE-BB35-160	● ZE-BB36-160	○ ZE-BB38-160
200	85	25	54	● ZE-BB35-200	● ZE-BB36-200	○ ZE-BB38-200
250	105	28	63	● ZE-BB35-250	● ZE-BB36-250	○ ZE-BB38-250
315	125	32	73	● ZE-BB35-315	● ZE-BB36-315	○ ZE-BB38-315
400	145	36	92	● ZE-BB35-400	● ZE-BB36-400	○ ZE-BB38-400
500	180	40	100	● ZE-BB35-500	● ZE-BB36-500	-
630/800	225	50	110	● ZE-BB35-630/800	○ ZE-BB36-630/800	-

Preis pro Satz / Price per set

Nachträglich bezogene harte Stufenbacken müssen im Futter ausgeschliffen werden
Hard jaws bought as spare parts have to be ground on the chuck



Backensätze für Planspiral-Drehfutter

Jaws for lathe chucks

Harte Grundbacken für Planspiral-Drehfutter

Hard base jaws for lathe chucks

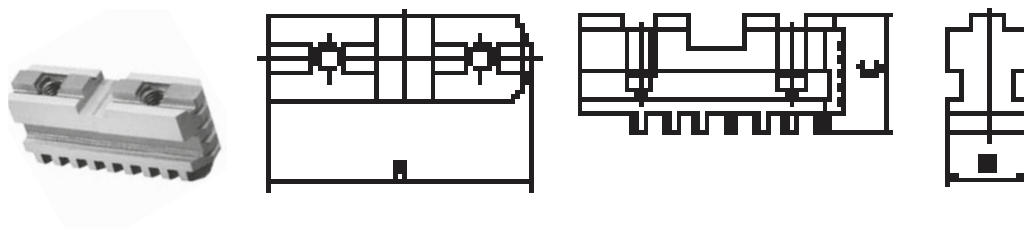

Für / for Ø mm	A mm	B mm	C mm	2-Ba. / 2-Jaw Art.-Nr. / Order no.	3-Ba. / 3-Jaw Art.-Nr. / Order no.	4-Ba. / 4-Jaw Art.-Nr. / Order no.	6-Ba. / 6-Jaw Art.-Nr. / Order no.
125	54	20	28	-	● ZE-GB35-125	● ZE-GB36-125	○ ZE-GB38-125
160	65	20	29	● ZE-GB31-160	● ZE-GB35-160	● ZE-GB36-160	○ ZE-GB38-160
200	79	25	33	● ZE-GB31-200	● ZE-GB35-200	● ZE-GB36-200	● ZE-GB38-200
250	92	28	36	● ZE-GB31-250	● ZE-GB35-250	● ZE-GB36-250	● ZE-GB38-250
315	110	32	40	● ZE-GB31-315	● ZE-GB35-315	● ZE-GB36-315	● ZE-GB38-315
400	130	36	49	● ZE-GB31-400	● ZE-GB35-400	● ZE-GB36-400	● ZE-GB38-400
500	166	40	54	-	● ZE-GB35-500	● ZE-GB36-500	○ ZE-GB38-500
630	210	50	54,5	-	● ZE-GB35-630	● ZE-GB36-630	○ ZE-GB38-630
800	225	50	54,5	-	● ZE-GB35-800	○ ZE-GB36-800	-

Preis pro Satz / Price per set

Harte, umkehrbare Aufsatzbacken für Planspiral-Drehfutter

Hard reversible top jaws for lathe chucks

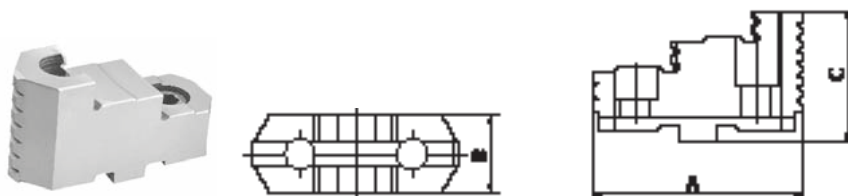

Für / for Ø mm	A mm	B mm	C mm	3-Ba. / 3-Jaw Art.-Nr. / Order no.	4-Ba. / 4-Jaw Art.-Nr. / Order no.	6-Ba. / 6-Jaw Art.-Nr. / Order no.
125	56	22	38,5	● ZE-HAB35-125	● ZE-HAB36-125	○ ZE-HAB38-125
160	67	25	41,5	● ZE-HAB35-160	● ZE-HAB36-160	○ ZE-HAB38-160
200	80	27	43,5	● ZE-HAB35-200	● ZE-HAB36-200	○ ZE-HAB38-200
250	95	32,5	51,5	● ZE-HAB35-250	● ZE-HAB36-250	○ ZE-HAB38-250
315	110	37	55	● ZE-HAB35-315	● ZE-HAB36-315	○ ZE-HAB38-315
400	127	42	64,5	● ZE-HAB35-400	● ZE-HAB36-400	○ ZE-HAB38-400
500	127	42	74,5	● ZE-HAB35-500	● ZE-HAB36-500	-
630/800	127	52	82	● ZE-HAB35-630/800	● ZE-HAB36-630/800	-

Preis pro Satz / Price per set

Nachträglich bezogene harte Stufenbacken müssen im Futter ausgeschliffen werden
Hard jaws bought as spare parts have to be ground on the chuck

Backensätze für Planspiral-Drehfutter Jaws for lathe chucks

Weiche Aufsatzbacken für Planspiral-Drehfutter Soft top jaws for lathe chucks

- Material C45

- material C45

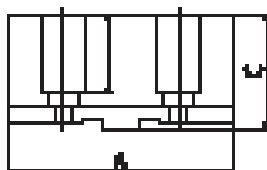
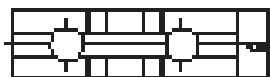
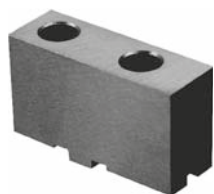

Für / for Ø mm	A mm	B mm	C mm	2-Ba. / 2-Jaw Art.-Nr. / Order no.	3-Ba. / 3-Jaw Art.-Nr. / Order no.	4-Ba. / 4-Jaw Art.-Nr. / Order no.	6-Ba. / 6-Jaw Art.-Nr. / Order no.
125	64	22	38,5	-	● ZE-WAB35-125	● ZE-WAB36-125	○ ZE-WAB38-125
160	78	25	41,5	● ZE-WAB31-160	● ZE-WAB35-160	● ZE-WAB36-160	● ZE-WAB38-160
200	90	27	43,5	● ZE-WAB31-200	● ZE-WAB35-200	● ZE-WAB36-200	● ZE-WAB38-200
250	106	32	51,5	● ZE-WAB31-250	● ZE-WAB35-250	● ZE-WAB36-250	● ZE-WAB38-250
315	120	37	55	● ZE-WAB31-315	● ZE-WAB35-315	● ZE-WAB36-315	● ZE-WAB38-315
400	140	42	64,5	● ZE-WAB31-400	● ZE-WAB35-400	● ZE-WAB36-400	● ZE-WAB38-400
500	140	42	74,5	-	● ZE-WAB35-500	● ZE-WAB36-500	○ ZE-WAB38-500
630/800	160	50	80	-	● ZE-WAB35-630/800	● ZE-WAB36-630/800	○ ZE-WAB38-630

Preis pro Satz / Price per set

Weiche Monoblockbacken für Planspiral-Drehfutter Soft solid jaws for lathe chucks

- Material C45

- material C45

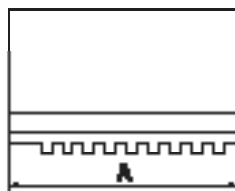
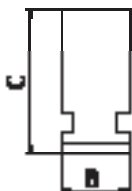

Für / for Ø mm	A mm	B mm	C mm	3-Ba. / 3-Jaw Art.-Nr. / Order no.	4-Ba. / 4-Jaw Art.-Nr. / Order no.	6-Ba. / 6-Jaw Art.-Nr. / Order no.
80	32	11	28	● ZE-MB35-080	-	-
100	42	15 *	32	● ZE-MB35-100	● ZE-MB36-100	○ ZE-MB38-100*
125	51	20 **	40	● ZE-MB35-125	● ZE-MB36-125	● ZE-MB38-125**
160	70	20	53	● ZE-MB35-160	● ZE-MB36-160	● ZE-MB38-160
200	78	25	58	● ZE-MB35-200	● ZE-MB36-200	● ZE-MB38-200
250	96	28	68	● ZE-MB35-250	● ZE-MB36-250	● ZE-MB38-250
315	118	32	78	● ZE-MB35-315	● ZE-MB36-315	● ZE-MB38-315
400	130	36	88	● ZE-MB35-400	● ZE-MB36-400	● ZE-MB38-400
500	180	40	98	● ZE-MB35-500	● ZE-MB36-500	-
630/800	225	50	108	● ZE-MB35-630/800	● ZE-MB36-630/800	-

Preis pro Satz / Price per set

* ZE-MB38-100: abweichendes Maß B = 11 / * Differing dimension B = 11
 ** ZE-MB38-125: abweichendes Maß B = 15 / ** Differing dimension B = 15



Zubehör und Ersatzteile für Planspiral-Drehfutter Accessories and spare parts for lathe chucks

1
1.1

Planspiral-Drehfutter, Backen und Zubehör / Lathe chucks, jaws and accessories



Planspiralringe Scroll plates

Für / for Ø mm	Art.-Nr. / Order no.
80	● ZE-PLR32-080
100	● ZE-PLR32-100
125	● ZE-PLR32-125
160	● ZE-PLR32-160
200	● ZE-PLR32-200
250	● ZE-PLR32-250
315	● ZE-PLR32-315
400	● ZE-PLR32-400
500	○ ZE-PLR32-500
630	○ ZE-PLR32-630
800	○ ZE-PLR32-800

Preis pro Stück / Price per piece



Ritzel für Gussfutter Pinions for cast iron chucks

Für / for Ø mm	Art.-Nr. / Order no.
80	● ZE-RI32-080
100	● ZE-RI32-100
125	● ZE-RI32-125
160	● ZE-RI32-160
200	● ZE-RI32-200
250	● ZE-RI32-250
315	● ZE-RI32-315
400	● ZE-RI32-400
500	● ZE-RI32-500
630	● ZE-RI32-630
800	● ZE-RI32-800

Preis pro Stück / Price per piece



Ritzel für Stahlfutter Pinions for steel chucks

Für / for Ø mm	Art.-Nr. / Order no.
125	● ZE-RI35-125
160	● ZE-RI35-160
200	● ZE-RI35-200
250	● ZE-RI35-250
315	● ZE-RI35-315
400	● ZE-RI35-400
500	● ZE-RI35-500
630	● ZE-RI35-630
800	● ZE-RI35-800

Preis pro Stück / Price per piece



Ersatzbolzen, DIN 55027 Studs, DIN 55027

KK / Taper	G mm	Ben. Stückzahl / Required quantity	Art.-Nr. / Order no.
3	M10 x 34	3	● ZE-SB-3
4	M10 x 39	3	● ZE-SB-4
5	M10 x 43	4	● ZE-SB-5
6	M12 x 50	4	● ZE-SB-6
8	M16 x 60	4	● ZE-SB-8
11	M20 x 75	6	● ZE-SB-11
15	M24 x 90	6	● ZE-SB-15

Preis pro Stück / Price per piece



Zubehör und Ersatzteile für Planspiral-Drehfutter Accessories and spare parts for lathe chucks

Ersatzbolzen, DIN 55029 (Camlock) Studs, DIN 55029 (Camlock)



KK / Taper	G mm	Ben. Stückzahl / Required quantity	Art.-Nr. / Order no.
3	M10 x 1	3	ZE-CB-3
4	M10 x 1	3	ZE-CB-4
5	M12 x 1	6	ZE-CB-5
6	M16 x 1,5	6	ZE-CB-6
8	M20 x 1,5	6	ZE-CB-8
11	M22 x 1,5	6	ZE-CB-11
15	M24 x 1,5	6	ZE-CB-15

Preis pro Stück / Price per piece

Schlüssel für Drehfutter Wrenches for lathe chucks



Für / for Ø mm	□	Art.-Nr. / Order no.
80	6	ZE-SCH-080
100/125	9	ZE-SCH-100/125
160/200	11	ZE-SCH-160/200
250/315	14	ZE-SCH-250/315
400	17	ZE-SCH-400
500/630	19	ZE-SCH-500/630
800	19	ZE-SCH-800

Preis pro Stück / Price per piece

Schraubensätze zu Grundbacken Screw sets for base jaws



Ø / Backen Ø / jaws	Art.-Nr. / Order no.
125/3	ZE-SATZ-125/3
125/4	ZE-SATZ-125/4
160/3	ZE-SATZ-160/3
160/4	ZE-SATZ-160/4
200/3	ZE-SATZ-200/3
200/4	ZE-SATZ-200/4
250/3	ZE-SATZ-250/3
250/4	ZE-SATZ-250/4
315/3	ZE-SATZ-315/3
315/4	ZE-SATZ-315/4
400/3	ZE-SATZ-400/3
400/4	ZE-SATZ-400/4

Für weiche und harte Aufsatzbacken / For soft and hard top jaws

Für Sechsbaken-Planspiraldrehfutter werden jeweils 2 Schraubensätze benötigt
For six-jaw lathe chucks, please order 2 sets of screws for three-jaw lathe chucks





Planspiral-Drehfutter BASIC

Lathe chucks BASIC

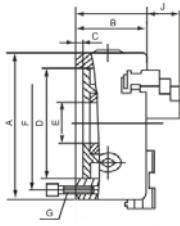

Dreibacken-Drehfutter BASIC

Three-jaw lathe chucks BASIC

Zylindrische Aufnahme nach Werksnorm, einteilige Backen
Centre mount acc. to factory standard, one-piece jaws

- zentrisch spannend

- self-centering

Guss / Cast iron

A (Ø) mm	D mm	F mm	E mm	J mm	B mm	C mm	G mm	Rundlauf / Runout Ø	RPM _{MAX} min ⁻¹	kg	Art.-Nr. / Order no.
80	55	66	16	16,5	50	4	3-M6	0,08	4000	2	● WAT-D80/3-ZGE
100	72	84	22	19,5	55	3	3-M8	0,08	3500	3	● WAT-D100/3-ZGE
125	95	108	30	26,5	58	4	3-M8	0,08	3000	5	● WAT-D125/3-ZGE
160	130	142	45	29	65	5	3-M8	0,08	2500	9	● WAT-D160/3-ZGE
200	165	180	65	34	75	5	3-M10	0,10	2000	16	● WAT-D200/3-ZGE
250	206	226	80	40	80	5	3-M12	0,10	1600	28	● WAT-D250/3-ZGE
315	260	285	100	57,5	90	6	3-M16	0,12	1200	47	● WAT-D315/3-ZGE
400	340	368	130	73,5	100	6	3-M16	0,12	1000	73	● WAT-D400/3-ZGE
500	440	465	210	87	115	6	6-M16	0,16	800	121	● WAT-D500/3-ZGE
630	560	595	260	89,5	131	7	6-M16	0,16	800	200	● WAT-D630/3-ZGE

Inkl. je 1 Satz Dreh- und Bohrbacken, Spanschlüssel, Befestigungsschrauben
Incl. 1 set each of solid jaws internally / externally stepped, wrench, fixing screws

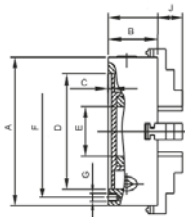

Vierbacken-Drehfutter BASIC

Four-jaw lathe chucks BASIC

Zylindrische Aufnahme nach Werksnorm, einteilige Backen
Centre mount acc. to factory standard, one-piece jaws

- zentrisch spannend

- self-centering

Guss / Cast iron

A (Ø) mm	D mm	F mm	E mm	J mm	B mm	C mm	G mm	Rundlauf / Runout Ø	RPM _{MAX} min ⁻¹	kg	Art.-Nr. / Order no.
80	55	66	16	16,5	50	4	3-M6	0,08	4000	2	● WAT-D80/4-ZGE
100	72	84	22	21	53,5	3	3-M8	0,08	3500	3	● WAT-D100/4-ZGE
125	95	108	30	26,5	58	4	3-M8	0,08	3000	5	● WAT-D125/4-ZGE
160	130	142	45	29	65	5	3-M8	0,08	2500	9	● WAT-D160/4-ZGE
200	165	180	65	34	75	5	3-M10	0,10	2000	16	● WAT-D200/4-ZGE
250	206	226	80	40	80	5	3-M12	0,10	1600	28	● WAT-D250/4-ZGE
315	260	285	100	57,5	90	6	3-M16	0,12	1200	47	● WAT-D315/4-ZGE
400	340	368	130	73,5	100	6	3-M16	0,12	1000	85	● WAT-D400/4-ZGE
500	440	465	210	87	115	6	6-M16	0,16	800	119	● WAT-D500/4-ZGE

Inkl. je 1 Satz Dreh- und Bohrbacken, Spanschlüssel, Befestigungsschrauben
Incl. 1 set each of solid jaws internally / externally stepped, wrench, fixing screws





Planspiral-Drehfutter BASIC

Lathe chucks BASIC

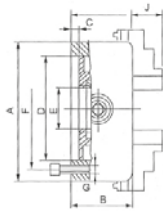

Sechsbacken-Drehfutter BASIC

Six-jaw lathe chucks BASIC

Zylindrische Aufnahme nach Werksnorm, einteilige Backen
Centre mount acc. to factory standard, one-piece jaws

- zentrisch spannend

- self-centering

Guss / Cast iron

A (Ø) mm	D mm	F mm	E mm	J mm	B mm	C mm	G mm	Rundlauf / Runout Ø	RPM _{MAX} min ⁻¹	kg	Art.-Nr. / Order no.
100	72	84	26	19,5	55	3	3-M6	0,08	3500	3	● WAT-D100/6-ZGE
130	100	115	35	28,5	58	5	3-M8	0,08	3000	6	● WAT-D130/6-ZGE
165	130	145	45	29	65	5	3-M8	0,08	2500	9	● WAT-D165/6-ZGE
200	165	180	65	34	75	6	3-M10	0,10	2000	16	● WAT-D200/6-ZGE
252	206	226	80	40	80	6	3-M12	0,10	1600	26	● WAT-D252/6-ZGE

Inkl. je 1 Satz Dreh- und Bohrbacken, Spanschlüssel, Befestigungsschrauben
Incl. 1 set each of solid jaws internally / externally stepped, wrench, fixing screws

Ersatzbacken auf Anfrage lieferbar
Spare jaws available upon request



Backensätze für Planspiral-Drehfutter BASIC

Jaws for lathe chucks BASIC

Weiche Monoblockbacken für Planspiral-Drehfutter BASIC

Soft solid jaws for lathe chucks BASIC

- Material C45

- material C45

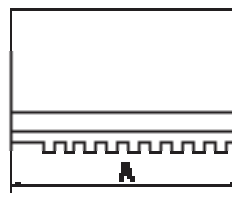
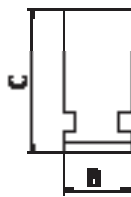
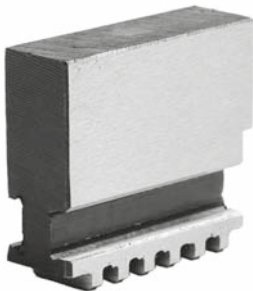

Für / for Ø mm	A mm	B mm	C mm	3-Ba. / 3-Jaw Art.-Nr. / Order no.	4-Ba. / 4-Jaw Art.-Nr. / Order no.
80	32	12	33	● D80/3-MB	● D80/4-MB
100	42	15	38	● D100/3-MB	● D100/4-MB
125	56	16	45	● D125/3-MB	● D125/4-MB
160	70	18,5	54	● D160/3-MB	● D160/4-MB
200	85	22	61	● D200/3-MB	● D200/4-MB
250	105	27	69	● D250/3-MB	● D250/4-MB
315	130	36	91	● D315/3-MB	● D315/4-MB
400	138	36	91	● D400/3-MB	● D400/4-MB

Preis pro Satz / Price per set



Keilstangen-Drehfutter Wedge bar lathe chucks



Zylindrische Aufnahme, einteilige Backen Centre mount, one-piece jaws

Mit Backen-Schnellwechselsystem.
Das Drehfutter besitzt eine hohe
Spannkraft bei geringem Kraftaufwand
und einen präzisen Rundlauf.

*With quick-change jaw system.
This chuck guarantees high clamping
power at minimum force requirement
and a high concentricity.*

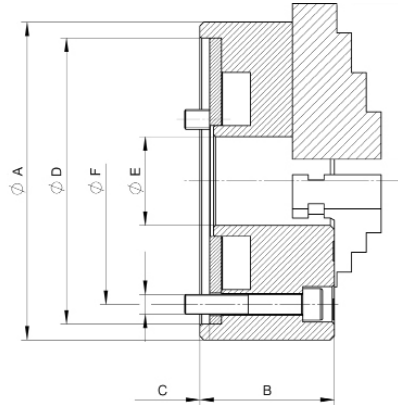

Stahl / Steel

A (Ø) mm	E mm	D mm	C mm	G	B mm	F mm	Max. Spannkraft / gripping force daN	Max. Drehzahl / speed min-1	kg	Art.-Nr. / Order no.
125	35	115	4	3xM8	46,5	100	3700	6000	3,7	▶ ZE-KS320-125
161	45	145	5	3xM10	63	125	8000	5200	8,6	▶ ZE-KS320-160
206	55	185	5	3xM12	81,3	160	12000	4600	18,5	▶ ZE-KS320-200
255	75	235	6	3xM16	92	200	17500	4000	32,5	▶ ZE-KS320-250
318	100	300	6	3xM20	111	250	21500	3200	62	▶ ZE-KS320-315
400	130	380	6	3xM24	118	315	23400	2200	102	○ ZE-KS320-400
500	180	460	6	3xM24	119	400	23400	1500	159	○ ZE-KS320-500
630	270	580	6	3xM24	143	520	28000	1000	293	○ ZE-KS320-630*

Inkl. je 1 Satz harter Stufenbacken, Kombi-Spannschlüssel, Befestigungsschrauben
Incl. 1 set of hard stepped jaws, wrench, fixing screws

Auf Anfrage auch mit geteilten Backen lieferbar / Also available with two-piece jaws upon request
* ZE-KS320-630: nur erhältlich mit geteilten Backen / only available with two-piece jaws

Backen für Keilstangen-Drehfutter Jaws for wedge bar lathe chucks



Harte, gestufte Umkehrbacke, Stück Hard reversible stepped jaw, piece

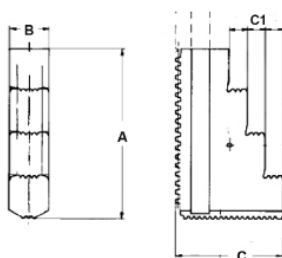

Für / for Ø mm	C1 mm	A mm	B mm	C mm	Art.-Nr. / Order no.
125	5	50	14	33,5	○ ZE-KHUB3-125
160	7,5	79	20	45	○ ZE-KHUB3-160
200	10	94	22	80	○ ZE-KHUB3-200
250	14	115	26	70	○ ZE-KHUB3-250
315	15	129	32	81	○ ZE-KHUB3-315
400	20	167	45	93	○ ZE-KHUB3-400



Backen für Keilstangen-Drehfutter Jaws for wedge bar lathe chucks

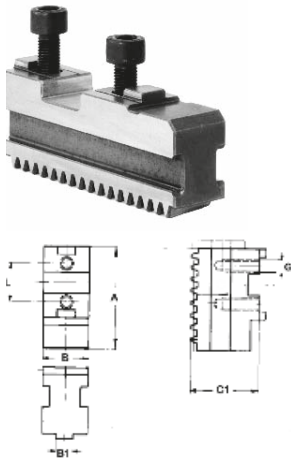

Harte Grundbacke, Stück Hard base jaw, piece

Für / for Ø mm	A mm	B mm	C mm	G mm	Art.-Nr. / Order no.
125*	47	14	19,5	M6	<input checked="" type="radio"/> ZE-KGB3-125
160	74	20	27	M8 x 1	<input checked="" type="radio"/> ZE-KGB3-160
200	90	22	32	M8 x 1	<input checked="" type="radio"/> ZE-KGB3-200
250	110	26	37	M12 x 1,5	<input checked="" type="radio"/> ZE-KGB3-250
315	125	32	43	M12 x 1,5	<input checked="" type="radio"/> ZE-KGB3-315
400	160	45	51	M16 x 1,5	<input checked="" type="radio"/> ZE-KGB3-400
500	200	55	58	M16 x 1,5	<input checked="" type="radio"/> ZE-KGB3-500
630	230	65	58	M20	<input checked="" type="radio"/> ZE-KGB3-630

* abweichende Zeichnung / * differing drawing

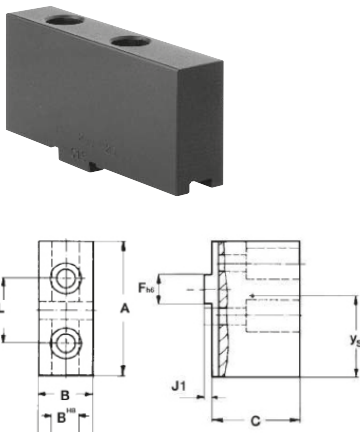

Weiche Aufsatzbacke, ungestuft, Stück Soft top jaw, piece

- Material C45

- material C45

Für / for Ø mm	A mm	B mm	C mm	Art.-Nr. / Order no.
125*	55	20	27,5	<input checked="" type="radio"/> ZE-KWAB3-125
160	85	20	35,5	<input checked="" type="radio"/> ZE-KWAB3-160
200	105	25	40	<input checked="" type="radio"/> ZE-KWAB3-200
250	125	30	55	<input checked="" type="radio"/> ZE-KWAB3-250
315	145	50	54	<input checked="" type="radio"/> ZE-KWAB3-315
400	180	50	80	<input checked="" type="radio"/> ZE-KWAB3-400
500	220	60	90	<input checked="" type="radio"/> ZE-KWAB3-500
630	260	65	110	<input checked="" type="radio"/> ZE-KWAB3-630

* abweichende Zeichnung / * differing drawing

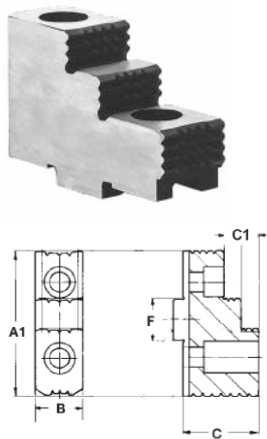

Harte Aufsatzbacke, umkehrbar, Stück Hard reversible top jaw, piece

Für / for Ø mm	C1 mm	A mm	B mm	C mm	Art.-Nr. / Order no.
160	7,5	63	20	32,5	<input checked="" type="radio"/> ZE-KHAB3-160
200	10	72	22	38	<input checked="" type="radio"/> ZE-KHAB3-200
250	14	90	32	50	<input checked="" type="radio"/> ZE-KHAB3-250
315	15	104	36	56	<input checked="" type="radio"/> ZE-KHAB3-315
400	20	130	45	75	<input checked="" type="radio"/> ZE-KHAB3-400
500	20	130	45	75	<input checked="" type="radio"/> ZE-KHAB3-500
630	30	185	65	97	<input checked="" type="radio"/> ZE-KHAB3-630

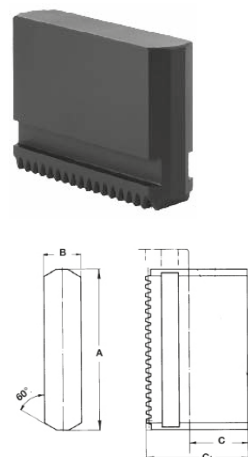

Weiche Monoblockbacke, Stück Soft solid jaw, piece

- Material C45

- material C45

Für / for Ø mm	A mm	B mm	C mm	Art.-Nr. / Order no.
160	79	20	45	<input checked="" type="radio"/> ZE-KMB3-160
200	94	22	60	<input checked="" type="radio"/> ZE-KMB3-200
250	115	26	70	<input checked="" type="radio"/> ZE-KMB3-250
315	130	32	81	<input checked="" type="radio"/> ZE-KMB3-315
400	176	45	93	<input checked="" type="radio"/> ZE-KMB3-400



Kombinierte Drehfutter Wescott Combined lathe chucks Wescott

Dreibacken-Drehfutter Wescott, zylindrische Aufnahme Three-jaw lathe chucks Wescott, centre mount

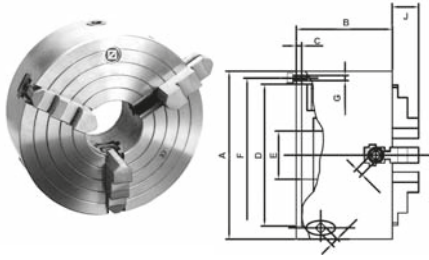

Backen zentrisch spannend und einzeln verstellbar. Das Drehfutter ist besonders geeignet zum Spannen von unregelmäßig geformten Werkstücken.

Self-centering and individually adjustable jaws. This lathe chuck is especially suitable for holding irregularly shaped work pieces.

Guss / Cast iron

A (Ø) mm	D mm	F mm	E mm	B mm	J mm	C mm	G mm	Art.-Nr. / Order no.
160	130	142	42	87	28	5	6-M8	● ZE-WG310-160
200	165	180	65	97	30	5	6-M10	● ZE-WG310-200
250	206	226	80	102	40	5	6-M12	▶ ZE-WG310-250
325	272	296	100	120	43	6	6-M16	▶ ZE-WG310-325

Inkl. je 1 Satz harter Umkehrbacken, Kombi-Spannschlüssel, Befestigungsschrauben
Incl. 1 set of hardened reversible jaws, wrench, fixing screws

Backensätze für Dreibacken-Drehfutter Wescott Jaws for three-jaw lathe chucks Wescott

Harte, gestufte Umkehrbacken Hard reversible stepped jaws

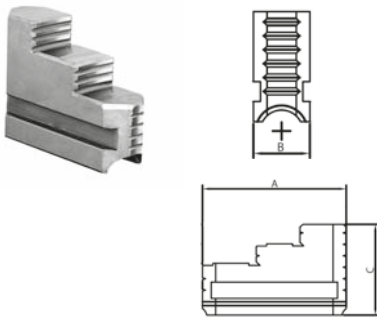

Für / for Ø mm	A mm	B mm	C mm	Art.-Nr. / Order no.
160	61	20	52	▶ ZE-WHUB3-160
200	75	25	57	▶ ZE-WHUB3-200
250	90	27	68	▶ ZE-WHUB3-250
325	110	34	79	▶ ZE-WHUB3-325

Preis pro Satz / Price per set

Weiche Monoblockbacken Soft solid jaws

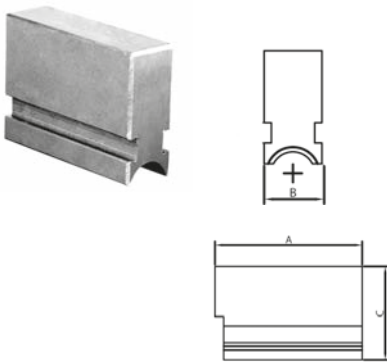

- Material 20 MnCr5

- material 20 MnCr5

Für / for Ø mm	A mm	B mm	C mm	Art.-Nr. / Order no.
160	61	20	52	▶ ZE-WMB3-160
200	75	25	57	▶ ZE-WMB3-200
250	90	27	68	▶ ZE-WMB3-250
325	110	34	79	▶ ZE-WMB3-325

Preis pro Satz / Price per set

Kombinierte Vierbacken-Drehfutter Wescott

Combined lathe chucks Wescott

Vierbacken-Drehfutter Wescott, zylindrische Aufnahme

Four-jaw lathe chucks Wescott, centre mount

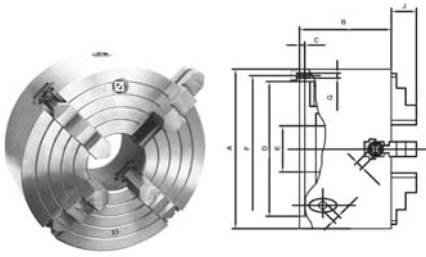

Backen zentrisch spannend und einzeln verstellbar. Das Drehfutter ist besonders geeignet zum Spannen von unregelmäßig geformten Werkstücken.

Self-centering and individually adjustable jaws. This lathe chuck is especially suitable for holding irregularly shaped work pieces.

Guss / Cast iron

A (Ø) mm	D mm	F mm	E mm	B mm	J mm	C mm	G mm	Art.-Nr. / Order no.
160	130	142	42	87	28	5	6-M8	ZE-WG410-160
200	165	180	65	97	30	5	6-M10	ZE-WG410-200
250	206	226	80	102	40	5	6-M12	ZE-WG410-250
325	272	296	100	120	43	6	6-M16	ZE-WG410-325

Inkl. je 1 Satz harter Umkehrbacken, Kombi-Spannschlüssel, Befestigungsschrauben
Incl. 1 set of hardened reversible jaws, wrench, fixing screws

Backensätze für Vierbacken-Drehfutter Wescott

Jaws for four-jaw lathe chucks Wescott

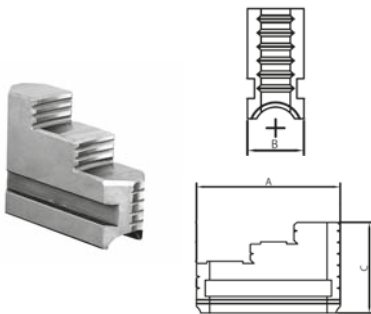

Harte, gestufte Umkehrbacken

Hard reversible stepped jaws

Für / for Ø mm	A mm	B mm	C mm	Art.-Nr. / Order no.
160	61	20	52	ZE-WHUB4-160
200	75	25	57	ZE-WHUB4-200
250	90	27	68	ZE-WHUB4-250
325	110	34	79	ZE-WHUB4-325

Preis pro Satz / Price per set

Weiche Monoblockbacken

Soft solid jaws

- Material 20 MnCr5

- material 20 MnCr5

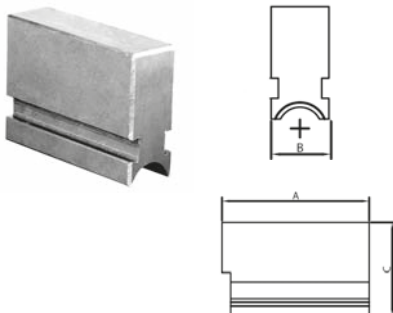

Für / for Ø mm	A mm	B mm	C mm	Art.-Nr. / Order no.
160	61	20	52	ZE-WMB4-160
200	75	25	57	ZE-WMB4-200
250	90	27	68	ZE-WMB4-250
325	110	34	79	ZE-WMB4-325

Preis pro Satz / Price per set

Planscheiben Independent chucks

Ab Ø 250 mit T-Nuten, ab Ø 160 Befestigung von vorne
From Ø 250 with T-grooves, from Ø 160 front mounting

Planscheiben
mit einteiligen Umkehrbacken /
Independent chucks
with one-piece jaws

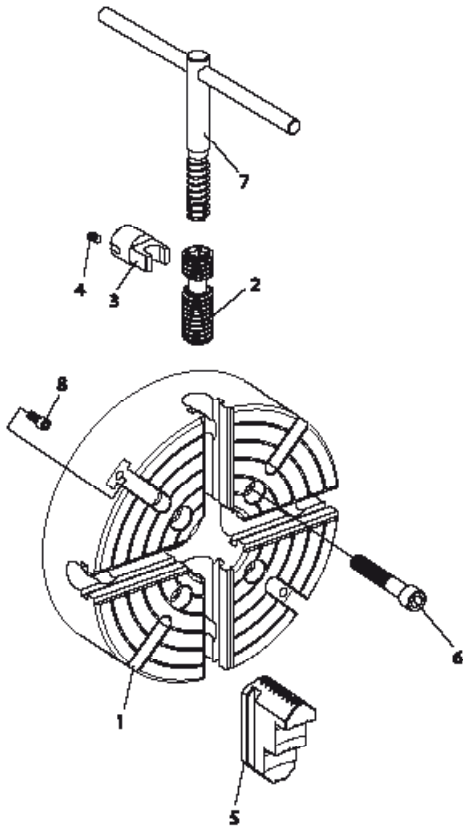

- 1. Futterkörper
- 2. Verstellspindel
- 3. Spindellager
- 4. Fixierschraube
- 5. Umkehraufsatzbacke
- 6. Befestigungsschraube
- 7. Schlüssel
- 8. T-Nut Schraube

- 1. Chuck body
- 2. Operating screw
- 3. Thrust bearing
- 4. Set screw
- 5. Hard solid reversible jaw
- 6. Chuck mounting bolt
- 7. Chuck wrench
- 8. T-Slot screw

Spannbereich / Clamping range

Ø mm	d1 min	d2 max	Ø max.
80	3	80	96
100	3	100	116
125	3	125	150
160	3	160	185
200	10	200	235
250	10	250	296
315	15	315	369
400	20	400	465
500	45	500	570
630	50	630	720
800	50	800	888

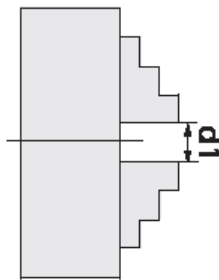

Planscheiben Independent chucks

Mit 4 einzeln verstellbaren Backen.
Die Planscheibe ist besonders geeignet zum Spannen von unregelmäßig geformten Werkstücken.

With 4 individually adjustable jaws.
This independent chuck is especially suitable for holding irregularly shaped work pieces.

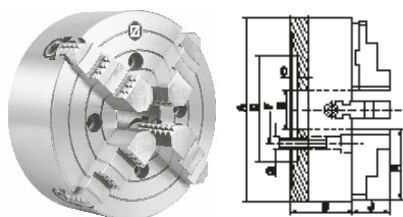

Zylindrische Aufnahme, einteilige Backen Centre mount, one-piece jaws

Guss / Cast iron

A (Ø) mm	B mm	C mm	D mm	E mm	F mm	G mm	H mm	J mm	RPM _{MAX} min-1	kg	Art.-Nr. / Order no.
80	42	3,5	55	22	66	4xM6	33	16	3000	1,9	ZE-4100-080
100	54	4	72	25	84	4xM8	42	23	3000	2,4	ZE-4100-100
125	56	4,5	95	30	108	4xM8	53	22	2500	5,0	ZE-4100-125
160	65	5	65	45	95	4xM10	61,5	31,5	2000	7,5	ZE-4100-160
200	75	6	75	56	95	4xM10	85	35	1800	10	ZE-4100-200
250	85	7	150	65	104,8	4xM12	92	40,3	1500	25	ZE-4100-250
315	95	7	175	80	133,4	4xM16	111	49,8	1200	39	ZE-4100-315
400	105	10	200	100	171,4	4xM16	129	49,8	800	61	ZE-4100-400
500	120	12	270	125	235	4xM20	152,5	59,8	500	105	ZE-4100-500
630	140	12	270	160	235	4xM20	177	59,8	400	211	ZE-4100-630
800	145	12	250	210	300	8xM20	202	70,8	300	319	ZE-4100-800

Inkl. 1 Satz einteiliger Umkehrbacken, Spannschlüssel, Befestigungsschrauben
Incl. 1 set hardened reversible jaws, wrench, fixing screws

Auf Anfrage auch mit geteilten Backen lieferbar / With two-piece jaws available upon request

Planscheiben in größeren Durchmessern und Ersatzbacken auf Anfrage lieferbar
Independent chucks with bigger diameters and spare jaws available upon request



Planscheiben

Independent chucks

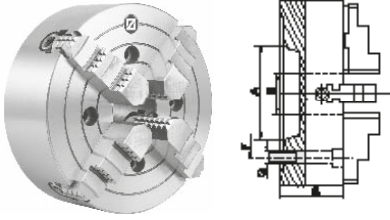

Kurzkegelaufnahme nach DIN 55026, einteilige Backen
According to DIN 55026, one-piece jaws

Guss / Cast iron

A Ø mm	KK Taper	B mm	D mm	E mm	F mm	G mm	RPM _{MAX} min-1	kg	Art.-Nr. / Order no.
200	4	75	63,5	50	82,6	4xM10	1800	17	○ ZE-4156-204
200	5	75	82,6	50	104,8	4xM10	1800	17	● ZE-4156-205
200	6	75	106,4	50	133,4	4xM12	1800	17	● ZE-4156-206
250	5	85	82,6	65	104,8	8xM10	1500	25,5	○ ZE-4156-255
250	6	85	106,4	65	133,4	4xM12	1500	25,5	○ ZE-4156-256
250	8	85	139,7	65	171,4	4xM16	1500	25,5	○ ZE-4156-258
315	5	95	82,6	80	104,8	4xM10	1200	40	○ ZE-4156-315
315	6	95	106,4	80	133,4	8xM12	1200	40	○ ZE-4156-316
315	8	95	139,7	80	171,4	4xM16	1200	40	○ ZE-4156-318
315	11	95	196,9	80	235	4xM20	1200	40	○ ZE-4156-311
400	6	105	106,4	100	133,4	8xM12	800	65	○ ZE-4156-406
400	8	105	139,7	100	171,4	4xM16	800	65	○ ZE-4156-408
400	11	105	196,9	100	235	4xM20	800	65	○ ZE-4156-411
500	8	120	139,7	125	171,4	8xM16	500	114	○ ZE-4156-508
500	11	120	196,9	125	235	8xM20	500	114	○ ZE-4156-511
630	8	140	139,7	125	171,4	8xM16	400	165	○ ZE-4156-638
630	11	140	196,9	160	235	8xM20	400	165	○ ZE-4156-611
630	15	140	285,8	160	330,2	4xM24	400	165	○ ZE-4156-615
800	11	145	196,9	180	235	8xM20	300	305	○ ZE-4156-811
800	15	145	285,8	180	330,2	8xM24	300	305	○ ZE-4156-815

Inkl. 1 Satz einteiliger Umkehrbacken, Spannschlüssel, Befestigungsschrauben
Incl. 1 set hardened reversible jaws, wrench, fixing screws

Auf Anfrage auch mit geteilten Backen lieferbar / With two-piece jaws available upon request

Planscheiben in größeren Durchmessern und Ersatzbacken auf Anfrage lieferbar
Independent chucks with bigger diameters and spare jaws available upon request

Planscheiben Independent chucks

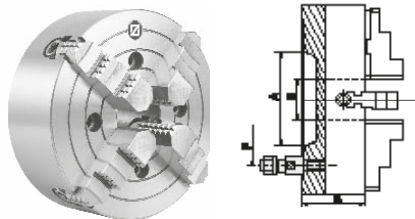

Kurzkegelaufnahme nach DIN 55027, einteilige Backen According to DIN 55027, one-piece jaws

Guss / Cast iron

A Ø mm	KK Taper	B mm	D mm	E mm	F mm	RPM _{MAX} min-1	kg	Art.-Nr. / Order no.
200	4	75	63,5	56	85	1800	10	● ZE-4157-204
200	5	75	82,6	56	104,8	1800	10	● ZE-4157-205
200	6	75	106,4	56	133,4	1800	10	● ZE-4157-206
250	5	85	82,6	65	104,8	1500	27,5	● ZE-4157-255
250	6	85	106,4	65	133,4	1500	27,5	● ZE-4157-256
250	8	85	139,7	65	171,4	1500	27,5	● ZE-4157-258
315	5	95	82,6	80	104,8	1200	39,5	● ZE-4157-315
315	6	95	106,4	80	133,4	1200	39,5	● ZE-4157-316
315	8	95	139,7	80	171,4	1200	39,5	● ZE-4157-318
315	11	95	196,9	80	235	1200	39,5	○ ZE-4157-311
400	6	105	106,4	100	133,4	800	60	● ZE-4157-406
400	8	105	139,7	100	171,4	800	60	● ZE-4157-408
400	11	105	196,9	100	235	800	60	● ZE-4157-411
500	8	120	139,7	125	171,4	500	95,5	● ZE-4157-508
500	11	120	196,9	125	235	500	95,5	● ZE-4157-511
630	8	140	139,7	125	171,4	400	165	● ZE-4157-638
630	11	140	196,9	160	235	400	165	● ZE-4157-611
630	15	140	285,8	160	330,2	400	165	○ ZE-4157-615
800	11	145	196,9	180	235	300	298	○ ZE-4157-811
800	15	145	285,8	180	330,2	300	298	○ ZE-4157-815

Inkl. 1 Satz einteiliger Umkehrbacken, Spanschlüssel, Befestigungsbolzen
Incl. 1 set hardened reversible jaws, wrench, fixing bolts

Auf Anfrage auch mit geteilten Backen lieferbar / With two-piece jaws available upon request

Planscheiben in größeren Durchmessern und Ersatzbacken auf Anfrage lieferbar
Independent chucks with bigger diameters and spare jaws available upon request

Planscheiben Independent chucks

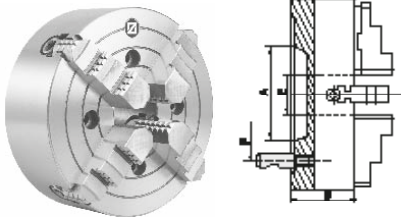

Kurzkegelaufnahme nach DIN 55029, einteilige Backen
According to DIN 55029, one-piece jaws

Guss / Cast iron

A Ø mm	KK Taper	B mm	D mm	E mm	F mm	RPM _{MAX} min-1	kg	Art.-Nr. / Order no.
160	3	65	54	45	70,6	2000	7,5	● ZE-4159-163
200	4	75	63,5	56	82,6	1800	10	● ZE-4159-204
200	5	75	82,6	56	104,8	1800	10	● ZE-4159-205
200	6	75	106,4	56	133,4	1800	10	● ZE-4159-206
250	5	85	82,6	65	104,8	1500	27,5	● ZE-4159-255
250	6	85	106,4	65	133,4	1500	27,5	● ZE-4159-256
250	8	85	139,7	65	171,4	1500	27,5	● ZE-4159-258
315	5	95	82,6	80	104,8	1200	39,5	● ZE-4159-315
315	6	95	106,4	80	133,4	1200	39,5	● ZE-4159-316
315	8	95	139,7	80	171,4	1200	39,5	● ZE-4159-318
315	11	95	196,9	80	235	1200	39,5	○ ZE-4159-311
400	6	105	106,4	100	133,4	800	60	● ZE-4159-406
400	8	105	139,7	100	171,4	800	60	● ZE-4159-408
400	11	105	196,9	100	235	800	60	● ZE-4159-411
500	8	120	139,7	125	171,4	500	95,5	● ZE-4159-508
500	11	120	196,9	125	235	500	95,5	● ZE-4159-511
630	8	140	139,7	125	171,4	400	165	● ZE-4159-638
630	11	140	196,9	160	235	400	165	● ZE-4159-611
630	15	140	285,8	160	330,2	400	165	○ ZE-4159-615
800	11	145	196,9	180	235	300	298	○ ZE-4159-811
800	15	145	285,8	180	330,2	300	298	○ ZE-4159-815

Inkl. 1 Satz einteiliger Umkehrbacken, Spannschlüssel, Befestigungsbolzen
Incl. 1 set hardened reversible jaws, wrench, fixing bolts

Auf Anfrage auch mit geteilten Backen lieferbar / With two-piece jaws available upon request

Planscheiben in größeren Durchmessern und Ersatzbacken auf Anfrage lieferbar
Independent chucks with bigger diameters and spare jaws available upon request

Flansche
Adaptor plates

Material = Stahl
Material = steel

Flansche nach DIN 55026 / DIN 55027 / DIN 55029
Weitere Flansche auf Anfrage

Adaptor plates according to DIN 55026 / DIN 55027 / DIN 55029
Further adaptor plates available upon request



Flansche für Drehfutter und Planscheiben

Adaptor plates for lathe and independent chucks



Stahl / Steel

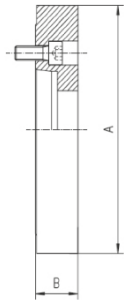

Kurzkegelaufnahme nach DIN 55026, futterseitig plan

According to DIN 55026, semi-machined

Für / for Ø mm	KK / Taper	A mm	B mm	E Durchlass / Thru-bore	Art.-Nr. / Order no.
160	5	162	23	79,5	● ZE-FP6-160/5
200	4	203	23	61	● ZE-FP6-200/4
200	5	203	23	79,5	● ZE-FP6-200/5
200	6	203	23	103	● ZE-FP6-200/6
250	5	253	28	79,5	● ZE-FP6-250/5
250	6	253	28	103	● ZE-FP6-250/6
250	8	253	28	136,2	● ZE-FP6-250/8
315	6	318	35	103	● ZE-FP6-315/6
315	8	318	35	136,2	● ZE-FP6-315/8
315	11	318	38	192,8	● ZE-FP6-315/11
400	6	405	35	103	○ ZE-FP6-400/6
400	8	405	35	136,2	○ ZE-FP6-400/8
400	11	405	35	192,8	○ ZE-FP6-400/11
500	8	505	35	136,2	○ ZE-FP6-500/8
500	11	505	36	192,8	○ ZE-FP6-500/11
500	15	505	42	281,5	○ ZE-FP6-500/15
630	8	635	45	136,2	○ ZE-FP6-630/8
630	11	635	45	192,8	○ ZE-FP6-630/11
630	15	635	45	281,5	○ ZE-FP6-630/15

Bitte beachten Sie, dass bei der DIN 55026 das Futter von vorne durchbohrt werden muss.
Please note that for DIN 55026 the chuck needs to be drilled for front mounting.

Kurzkegelaufnahme nach DIN 55027, futterseitig plan

According to DIN 55027, semi-machined



Stahl / Steel

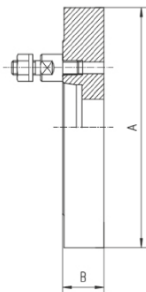

Für / for Ø mm	KK / Taper	A mm	B mm	E Durchlass / Thru-bore	Art.-Nr. / Order no.
125	3	127	20	51,4	● ZE-FP7-125/3
125	4	127	20	61	● ZE-FP7-125/4
160	3	162	23	51,4	● ZE-FP7-160/3
160	4	162	23	61	● ZE-FP7-160/4
160	5	162	23	79,5	● ZE-FP7-160/5
200	4	203	23	61	● ZE-FP7-200/4
200	5	203	23	79,5	● ZE-FP7-200/5
200	6	203	23	103	● ZE-FP7-200/6
250	5	253	28	79,5	● ZE-FP7-250/5
250	6	253	28	103	● ZE-FP7-250/6
250	8	253	28	136,2	● ZE-FP7-250/8
315	6	318	35	103	● ZE-FP7-315/6
315	8	318	35	136,2	● ZE-FP7-315/8
315	11	318	35	192,8	● ZE-FP7-315/11
400	6	405	35	103	● ZE-FP7-400/6
400	8	405	35	136,2	● ZE-FP7-400/8
400	11	405	35	192,8	● ZE-FP7-400/11
500	8	505	36	136,2	● ZE-FP7-500/8
500	11	505	36	192,8	● ZE-FP7-500/11
500	15	505	36	281,5	○ ZE-FP7-500/15
630	8	635	45	136,2	● ZE-FP7-630/8
630	11	635	45	192,8	● ZE-FP7-630/11
630	15	635	45	281,5	● ZE-FP7-630/15

Flansche für Drehfutter und Planscheiben

Adaptor plates for lathe and independent chucks

1
1.6

Flansche / Adaptor plates



Stahl / Steel

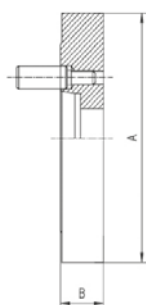

Kurzkegelaufnahme nach DIN 55029, futterseitig plan

According to DIN 55029, semi-machined

Für / for Ø mm	KK / Taper	A mm	B mm	E Durchlass / Thru-bore	Art.-Nr. / Order no.
125	3	127	28	51,4	● ZE-FP9-125/3
125	4	127	28	61	● ZE-FP9-125/4
160	3	162	29	51,4	● ZE-FP9-160/3
160	4	162	29	61	● ZE-FP9-160/4
160	5	162	32	79,5	● ZE-FP9-160/5
200	4	203	29	61	● ZE-FP9-200/4
200	5	203	32	79,5	● ZE-FP9-200/5
200	6	203	39	103	● ZE-FP9-200/6
250	5	253	32	79,5	● ZE-FP9-250/5
250	6	253	39	103	● ZE-FP9-250/6
250	8	253	42	136,2	● ZE-FP9-250/8
315	6	318	42	103	● ZE-FP9-315/6
315	8	318	45	136,2	● ZE-FP9-315/8
315	11	318	52	192,8	● ZE-FP9-315/11
400	6	405	42	103	○ ZE-FP9-400/6
400	8	405	45	136,2	● ZE-FP9-400/8
400	11	405	49	192,8	● ZE-FP9-400/11
500	8	505	42	136,2	● ZE-FP9-500/8
500	11	505	49	192,8	● ZE-FP9-500/11
630	8	635	42	136,2	● ZE-FP9-630/8
630	11	635	49	192,8	● ZE-FP9-630/11
630	15	635	52	281,5	● ZE-FP9-630/15

Kurzkegelaufnahme nach DIN 55026 (A2), fertig bearbeitet für Drehfutter nach DIN 6350

According to DIN 55026 (A2), fully machined for chucks acc. to DIN 6350



Stahl / Steel

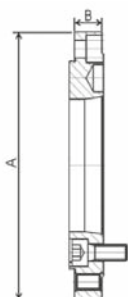

Für / for Ø mm	KK / Taper	A mm	B mm	F Lochkreis / PCD mm	E Durchlass / Thru-bore mm	Art.-Nr. / Order no.
160	5	160	21	104,8	79,5	● ZE-FV6-160/5
200	4	200	21	82,6	61	○ ZE-FV6-200/4
200	5	200	21	104,8	79,5	● ZE-FV6-200/5
200	6	200	21	133,4	103	● ZE-FV6-200/6
250	5	250	26	104,8	79,5	○ ZE-FV6-250/5
250	6	250	26	133,4	103	● ZE-FV6-250/6
250	8	250	26	171,4	136,2	○ ZE-FV6-250/8
315	6	315	33	133,4	103	● ZE-FV6-315/6
315	8	315	33	171,4	136,2	○ ZE-FV6-315/8
315	11	315	35	235	192,8	● ZE-FV6-315/11
400	6	400	33	133,4	103	○ ZE-FV6-400/6
400	8	400	33	171,4	136,2	○ ZE-FV6-400/8
400	11	400	33	235	192,8	○ ZE-FV6-400/11
500	8	500	34	171,4	136,2	○ ZE-FV6-500/8
500	11	500	34	235	192,8	○ ZE-FV6-500/11
630	8	630	42	171,4	136,2	○ ZE-FV6-630/8
630	11	630	42	235	192,8	○ ZE-FV6-630/11
630	15	630	42	330,2	281,5	○ ZE-FV6-630/15

Bitte beachten Sie, dass bei der DIN 55026 das Futter von vorne durchbohrt werden muss.
Please note that for DIN 55026 the chuck needs to be drilled for front mounting.



Flansche für Drehfutter und Planscheiben

Adaptor plates for lathe and independent chucks

1
1.6

Flansche / Adaptor plates



Stahl / Steel

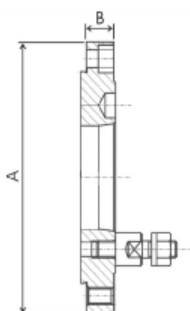

Kurzkegelaufnahme nach DIN 55027, fertig bearbeitet für Drehfutter nach DIN 6350

According to DIN 55027, fully machined for chucks acc. to DIN 6350

Für / for Ø mm	KK / Taper	A mm	B mm	F Lochkreis / PCD mm	E Durchlass / Thru-bore mm	Art.-Nr. / Order no.
125	3	125	18,5	75	51,4	ZE-FV7-125/3
125	4	125	21	85	61	ZE-FV7-125/4
160	3	160	21	75	51,4	ZE-FV7-160/3
160	4	160	21	85	61	ZE-FV7-160/4
160	5	160	21	104,8	79,5	ZE-FV7-160/5
200	4	200	21	85	61	ZE-FV7-200/4
200	5	200	21	104,8	79,5	ZE-FV7-200/5
200	6	200	21	133,4	103	ZE-FV7-200/6
250	5	250	26	104,8	79,5	ZE-FV7-250/5
250	6	250	26	133,4	103	ZE-FV7-250/6
250	8	250	26	171,4	136,2	ZE-FV7-250/8
315	6	315	33	133,4	103	ZE-FV7-315/6
315	8	315	33	171,4	136,2	ZE-FV7-315/8
315	11	315	33	235	192,8	ZE-FV7-315/11
400	6	400	33	133,4	103	ZE-FV7-400/6
400	8	400	33	171,4	136,2	ZE-FV7-400/8
400	11	400	33	235	192,8	ZE-FV7-400/11
500	8	500	34	171,4	136,2	ZE-FV7-500/8
500	11	500	34	235	192,8	ZE-FV7-500/11
630	8	630	42	171,4	136,2	ZE-FV7-630/8
630	11	630	42	235	192,8	ZE-FV7-630/11
630	15	630	42	330,2	281,5	ZE-FV7-630/15

Kurzkegelaufnahme nach DIN 55029, fertig bearbeitet für Drehfutter nach DIN 6350

According to DIN 55029, fully machined for chucks acc. to DIN 6350



Stahl / Steel

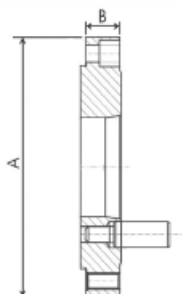

Für / for Ø mm	KK / Taper	A mm	B mm	F Lochkreis / PCD mm	E Durchlass / Thru-bore mm	Art.-Nr. / Order no.
125	3	125	26	70,6	51,4	ZE-FV9-125/3
125	4	125	26	82,6	61	ZE-FV9-125/4
160	3	160	27	70,6	51,4	ZE-FV9-160/3
160	4	160	27	82,6	61	ZE-FV9-160/4
160	5	160	30	104,8	79,5	ZE-FV9-160/5
200	4	200	27	82,6	61	ZE-FV9-200/4
200	5	200	30	104,8	79,5	ZE-FV9-200/5
200	6	200	36,5	133,4	103	ZE-FV9-200/6
250	5	250	30	104,8	79,5	ZE-FV9-250/5
250	6	250	36,5	133,4	103	ZE-FV9-250/6
250	8	250	39	171,4	136,2	ZE-FV9-250/8
315	6	315	39,5	133,4	103	ZE-FV9-315/6
315	8	315	42	171,4	136,2	ZE-FV9-315/8
315	11	315	52	235	192,8	ZE-FV9-315/11
400	6	400	39,5	133,4	103	ZE-FV9-400/6
400	8	400	39	171,4	136,2	ZE-FV9-400/8
400	11	400	47	235	192,8	ZE-FV9-400/11
500	8	500	39	171,4	136,2	ZE-FV9-500/8
500	11	500	47	235	192,8	ZE-FV9-500/11
500	15	500	50	330,2	281,5	ZE-FV9-500/15
630	8	630	39	171,4	136,2	ZE-FV9-630/8
630	11	630	47	235	192,8	ZE-FV9-630/11
630	15	630	50	330,2	281,5	ZE-FV9-630/15



Flansche für Drehfutter und Planscheiben

Adaptor plates for lathe and independent chucks

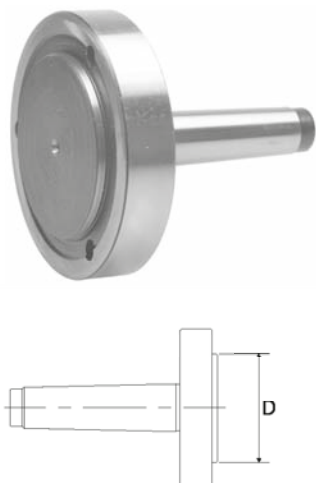

Fester MK-Futterflansch

Fixed flange with MT

- für zylindrische Drehfutter

- for chucks with centre mount

A (∅) mm	D mm	MK / MT	Art.-Nr. / Order no.
80	55	2	ZE-FMF-2/80
100	72	2	ZE-FMF-2/100
125	95	2	ZE-FMF-2/125
125	95	3	ZE-FMF-3/125
160	130	3	ZE-FMF-3/160

Passende Dreibacken-Drehfutter siehe Seite 28
Suitable three-jaw lathe chucks see page 28

MK-Grundkörper für mitlaufenden Futterflansch

MT base body for revolving adaptor

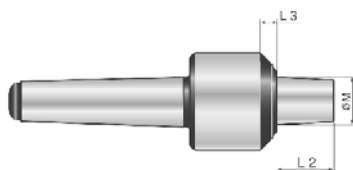

MK / MT	M mm	L2 mm	L3 mm	Art.-Nr. / Order no.
3	35	43	5	13-MGK-MK3
4	35	43	5	13-MGK-MK4
5	35	43	5	13-MGK-MK5
6	35	43	5	13-MGK-MK6
M80	35	44	6	13-MGK-M80

MK-Grundkörper für festen Futterflansch

MT base body for fixed adaptor

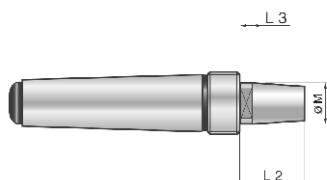

MK / MT	M mm	L2 mm	L3 mm	Art.-Nr. / Order no.
3	35	55	17	13-FGK-MK3
4	35	55	17	13-FGK-MK4
5	35	55	17	13-FGK-MK5
6	35	55	17	13-FGK-MK6

Futterflansch für MK-Grundkörper

Chuck adaptor for MT-base body

- für Drehfutter nach DIN 6350

- for chucks according to DIN 6350

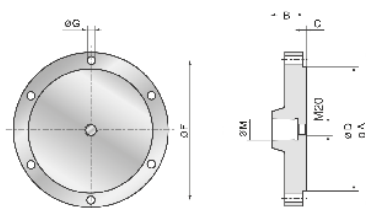

A mm	M mm	F mm	G mm	B mm	C mm	D mm	Art.-Nr. / Order no.
100	35	83	6,5	52,2	2,5	70	13-FFL-100
160	35	140	11	51,5	3,5	125	13-FFL-160
200	35	176	11	50,5	3,5	160	13-FFL-200
250	35	224	13	50,5	4,5	200	13-FFL-250

Drehfutter und Planscheiben

Sonderanfertigungen bis 5000 mm

Zum Beispiel:

- 8-Backen-Planspiralfutter/-Planscheiben
- Schwerlastplanscheiben
- Aufspannscheiben
- Wescott-Futter
- Kraftspannfutter

► **lieferbar auf Anfrage**



Big diameter chucks

Special designs up to 5000 mm

For example:

- 8-jaw lathe chucks/independent chucks
- Heavy-duty independent chucks
- Face plates
- Wescott lathe chucks
- Power chucks

➤ *available upon request*



Backen-Ausdrehringe Jaw turning rings

1
1.8

Backen-Ausdrehringe / Jaw turning rings



Für Innen- und Außenspannung For internal and external clamping

Das Set besteht aus einzelnen Ringen aus gehärtetem Spezialstahl mit je 3 Kurvensegmenten, die über 3 x 120° sowohl am inneren als auch am äußeren Umfang angeordnet sind. Durch die patentierten Ringe ist es möglich, Spannbacken präzise auszdrehen. Durch die stufenlose Einstellmöglichkeit kann man exakt soviel Material entfernen, wie nötig ist. Dies spart Zeit und Werkzeugkosten.

This set comprises individual rings from hardened special-purpose steel each consisting of 3 curved segments (3 x 120°) to be arranged both at the inner and outer circumference. These patented rings allow to turn-out jaws to a maximum precision. Thanks to an infinite adjustability it is possible to remove an exact amount of material thus saving set up time and costs.

- Innen- und Außenspannung mit 1 Ring
 - stufenloser Spannungsbereich für alle Futtergrößen
 - 1/10 mm genaue Einstellung des Drehdurchessers
 - optimale Zugänglichkeit des Werkzeuges
 - schnelle und flexible Handhabung
 - hohe Kosteneinsparung bei Spannbacken
 - geringe Rüstkosten
 - lieferbar für alle Futtergrößen von Ø 80 - 1000 mm
- internal and external clamping with only 1 ring
 - infinitely adjustable clamping range for all chucks
 - exact adjustment of boring diameter (1/10 mm precision)
 - ease of handling
 - less clamping jaws required
 - reduced set up times
 - available for all chuck sizes Ø 80 - 1000 mm

Für 3-Backen-Drehfutter For 3-jaw lathe chucks

Standard Ausführung Standard version

Größe / Size	Ringe / Rings	Spannbolzen inkl. / incl. clamping pin	Arbeitsbereich / Range	Art.-Nr. / Order no.
S-3	20	Je / each 3x M8 / M10	Ø = 0-200 mm	▶ 24-19508-S
L-3	29	Je / each 3x M8 / M10 / M12	Ø = 0-315 mm	▶ 24-19508-L
XL-3	10	Je / each 3x M16 / M20	Ø = 400-630 mm	▶ 24-19508-XL

Premium Ausführung Premium version

Inkl. flexiblen, verstellbaren Spannbolzen, die bis zu 1,5 mm der Schraubensenkung ausgleichen

Incl. flexible, adjustable clamping pins, which can compensate up to 1,5 mm of the bore

Größe / Size	Ringe / Rings	Spannbolzen inkl. / incl. clamping pin	Arbeitsbereich / Range	Art.-Nr. / Order no.
S-3	20	Je / each 3x M8 / M10	Ø = 0-200 mm	▶ 24-21508-S
L-3	29	Je / each 3x M8 / M10 / M12	Ø = 0-315 mm	▶ 24-21508-L
XL-3	10	Je / each 3x M16 / M20	Ø = 400-630 mm	▶ 24-21508-XL

Weitere Spannbolzen auf Anfrage lieferbar Other clamping pins available upon request



Backen-Ausdrehringe Jaw turning rings

Für 4-Backen-Drehfutter / For 4-jaw lathe chucks



Größe / Size	Ringe / Rings	Spannbolzen inkl. / incl. clamping pin	Arbeitsbereich / Range	Art.-Nr. / Order no.
S-4	20	Je / each 4x M8 / M10	Ø = 80-200 mm	▶ 24-41508-S



Größe / Size	Ringe / Rings	Spannbolzen inkl. / incl. clamping pin	Arbeitsbereich / Range	Art.-Nr. / Order no.
L-4	29	Je / each 4x M8 / M10 / M12	Ø = 80-250 mm	▶ 24-41508-L



Größe / Size	Ringe / Rings	Spannbolzen inkl. / incl. clamping pin	Arbeitsbereich / Range	Art.-Nr. / Order no.
XL-4	15	Je / each 4x M10 / M12 / M16	Ø = 200-500 mm	▶ 24-41508-XL

Für 6-Backen-Drehfutter / For 6-jaw lathe chucks



Größe / Size	Ringe / Rings	Spannbolzen inkl. / incl. clamping pin	Arbeitsbereich / Range	Art.-Nr. / Order no.
L-6	29	Je / each 6x M8 / M10 / M12	Ø = 80-250 mm	▶ 24-61508-L



Größe / Size	Ringe / Rings	Spannbolzen inkl. / incl. clamping pin	Arbeitsbereich / Range	Art.-Nr. / Order no.
XL-6	25	Je / each 4x M10 / M12 / M16	Ø = 200-500 mm	▶ 24-61508-XL

Für 2-, 3-, 4- und 6-Backen-Drehfutter / For 2-, 3-, 4- and 6-jaw lathe chucks



Größe / Size	Ringe / Rings	Spannbolzen inkl. / incl. clamping pin	Arbeitsbereich / Range Ø	Art.-Nr. / Order no.
XL 2/3/4/6	25	Je / each 6x M8 / M10 / M12 / M16	160-500 mm	▶ 24-81508-SET
		Je / each 4x M8 / M10		
		Je / each 4x M12 / M16		



Backen-Ausdrehvorrichtungen Jaw turning fixtures

Ausdrehvorrichtungen fur Dreibacken-Planspiralfutter Jaw turning fixtures for three-jaw scroll chucks

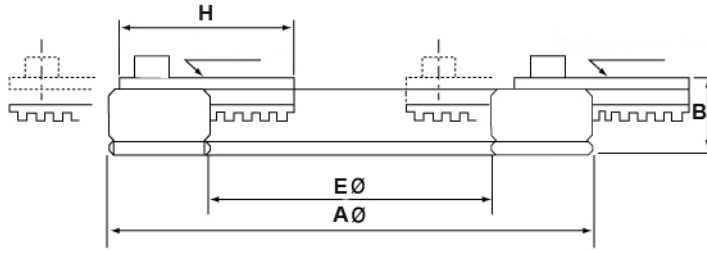

Fur Futter / For chuck	E Ø mm	A Ø mm	B mm	H mm	Einhangebereiche / Adjusting ranges mm	Max. Spannkraft / Max. gripping force (kN)	Max. Drehzahl / Max. speed (min-1)	kg	Art.-Nr. / Order no.
Ø 125-200	100	170	26	61	56-124 / 134-200	14,7	800	3	ZE-ADP3-200
Ø 160-250	125	200	26	61	85-150 / 170-230	14,7	700	4	ZE-ADP3-250
Ø 200-315	160	248	31	80	100-190 / 220-300	17,1	600	6	ZE-ADP3-315

Backen-Ausdrehringe fur Kraftspannfutter siehe Seite 66
Jaw turning rings for power chucks see page 66

Drehfutteranschlage Work piece stops



Zum Spannen von kurzen Teilen.

For clamping of short work pieces.

- wird durch 3 Magnete am Futterkorper befestigt
- parallel geschliffen
- Positionsgenauigkeit ±0,01 mm
- fur Werkstucke von Ø 15 - Ø 130 mm

- is fixed by 3 magnets onto the chuck body
- parallel ground
- accuracy of ±0,01 mm
- for work pieces Ø 15 - Ø 130 mm

Material: Aluminium

Material: Aluminium

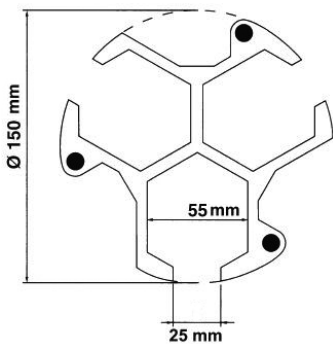

Hohe / Height mm	Art.-Nr. / Order no.
15	ZE-DFA-15
20	ZE-DFA-20
25	ZE-DFA-25
30	ZE-DFA-30
35	ZE-DFA-35
Satz / Set (15, 20, 25, 30, 35)	
	ZE-DFA-SATZ



Kraftspannfutter, Backen und Zubehör Power chucks, jaws and accessories

AUTOStrong Kraftspannfutter AUTOStrong power chucks

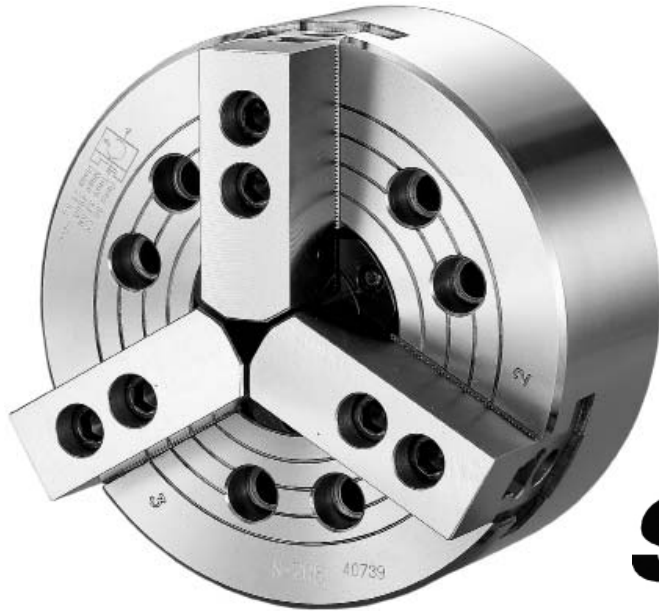

AUTO
Strong

Kraftspannfutter

Kraftspannfutter mit zylindrischer Aufnahme oder Kurzkegelaufnahme:

- Stahl
- 2-, 3- und 4-Backen
- ohne Durchgangsbohrung
- mit Durchgangsbohrung
- mit großer Durchgangsbohrung

Andere Aufnahmen auf Anfrage.

Alle Verschleißteile gehärtet und geschliffen für hohe Rundlaufgenauigkeit und Langlebigkeit. Schmiernippel in jeder Grundbacke.

Dreibacken-Keilstangen-Kraftspannfutter

Pneumatische Vorderendfutter

Hydraulikzylinder

Stationäre Kraftspannfutter

Power chucks

Power chucks with centre mount or taper mount

- steel
- 2, 3, and 4 jaws
- without bore
- with bore
- with big bore

Other mountings available upon request.

All sliding surfaces are hardened and ground for high runout precision and long service life. Lubrication nipple in each base jaw.

Three-jaw wedge bar power chuck

Pneumatic power chucks

Hydraulic cylinders

Stationary power chucks

Zweibacken-Kraftspannfutter mit Durchgangsbohrung - 1,5 x 60°

Two-jaw power chucks with bore - 1,5 x 60°

Strong AUTO

Zylindrische Aufnahme, mit Durchgangsbohrung
Centre mount, with bore

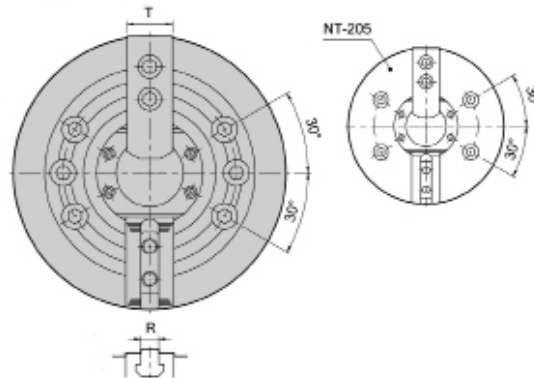
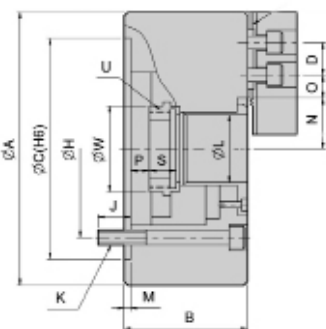

Stahl / Steel

Typ / Type	Backenhub / Jaw stroke mm	Zugrohrhub / Plunger stroke mm	Max. Betätigungskraft / Max. draw bar pull force (kN)	Max. Spannkraft / Max. gripping force (kN)	Max. Betätigungsdruck / Max. operating pressure (kN)	Passende harte Aufsatzbacken / Matching hard jaws	Passende weiche Aufsatzbacken / Matching soft jaws	Passender Zylinder / Matching Cylinder	Max. Drehzahl / Max. speed (rpm)	kg	Art.-Nr. / Order no.
NT-205	5,4	10	11,66	24	19,5	HJ05	HC05	M1036	7000	6,8	● 29-NT-205
NT-206	5,5	12	14,66	38	18,9	HJ06	HC06	M1246	6000	12,8	● 29-NT-206
NT-208	7,4	16	23,20	58,59	17,3	HJ08	HC08	M1552	4900	22	● 29-NT-208
NT-210	8,8	19	28,70	74	18,4	HJ10	HC10	M1875	4200	34	● 29-NT-210
NT-212	10,6	23	38	98	18,4	HJ12	HC12	M2091	3400	55	● 29-NT-212
NT-215	10,6	23	47,29	12	15,3	HJ15	HC15	M2511	2500	106	○ 29-NT-215
NT-218	10,6	23	47,29	12	15,3	HJ15	HC15	M2511	2000	122	○ 29-NT-218

Inkl. je 1 Satz Grund- und weiche Aufsatzbacken, Befestigungsschrauben, Zugrohradapterrohling
 Incl. 1 set each of hardened base jaws and soft top jaws, fixation screws, blank draw tube adaptor

Typ / Type	A mm	B mm	C(H6) mm	S mm	H mm	M mm	T mm	R mm	L mm	K	W mm	N max.	O max.	O min.	P max.	P min.	J mm	U max.	D mm
NT-205	135	60	110	20	82,55	4	23	10	33	3-M10	45	26,5	19,75	7,75	1	-9	15,5	M40x1,5	14
NT-206	169	81	140	19	104,78	5	32	12	45	6-M10	60	32	22,75	9,25	11	-1	16	M55x2	20
NT-208	210	91	170	20,5	133,35	5	37	14	52	6-M12	66	38,7	29,75	14,75	14,5	-1,5	20	M60x2	25
NT-210	254	100	220	25	171,45	5	42	16	75	6-M16	94	51	33,75	14,25	8,5	-10,5	22	M85x2	30
NT-212	304	110	220	28	171,45	6	52	21	91	6-M16	108	61,3	45,75	15,75	8	-15	23	M100x2	30
NT-215	381	133	300	43	235	6	62	22	117,5	6-M20	139	82	46,75	13,75	7	-16	30	M130x2	43
NT-218	450	133	300	43	235	6	62	22	117,5	6-M20	139	82	79,75	15,25	7	-16	35	M130x2	43

Backen kompatibel zu Kitagawa Typ BT200
Jaws compatible with Kitagawa type BT200



Zwei- / Dreibacken-Kombinations-Kraftspannfutter mit Durchgangsbohrung - 1,5 x 60°

Two- / Three-jaw combined power chucks with bore - 1,5 x 60°



DIN 55026, mit Durchgangsbohrung According to DIN 55026, with bore

- Kann als 2- oder 3-Backenfutter verwendet werden
- can be used as 2- or 3-jaw-chuck

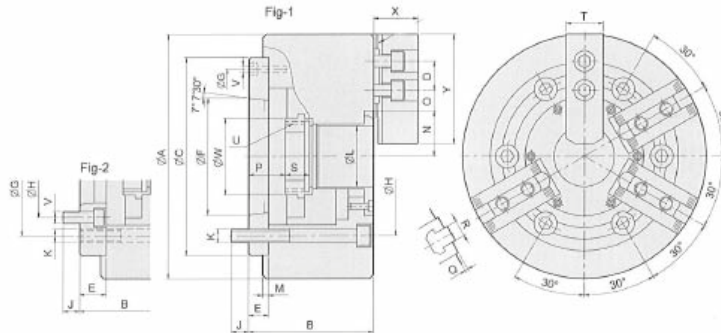
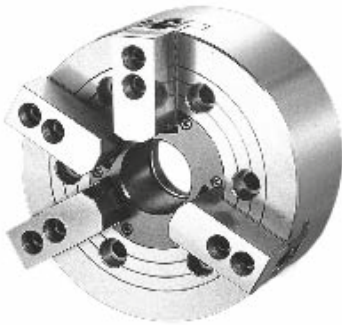

Stahl / Steel

Typ / Type	Backenhub / Jaw stroke mm	Zugrohrhub / Plunger stroke mm	Max. Betätigungskraft / Max. pull force (kN)	Max. Spannkraft / Max. gripping force (kN)	Max. Betätigungsdruck / Max. operating pressure (kN)	Passende harte Aufsatzbacken / Matching hard jaws	Passende weiche Aufsatzbacken / Matching soft jaws	Passender Zylinder / Matching Cylinder	Max. Drehzahl / Max. speed (rpm)	kg	Art.-Nr. / Order no.
NHT-208A5	7,4	16	(2-Ba.) 14,66 (3-Ba.) 21,99	38 56,99	12.1 17.2	HJ06	HC08-1	M1552	3500	26	● 29-NHT-208A5
NHT-208A6	7,4	16	(2-Ba.) 14,66 (3-Ba.) 21,99	38 56,99	12.1 17.2	HJ06	HC08-1	M1552	3500	25	● 29-NHT-208A6

Typ / Type	A mm	B mm	C(H6) mm	M mm	H mm	L mm	K mm	J mm	D mm	N max. mm	O max. mm	O min. mm	P max. mm	P min. mm	T mm	R mm	S mm	U max	W mm
NHT-208A5	210	113	170	5	104,78	52	6xM12	13	20	41,8	34	7,5	37,5	21,5	32	12	20,5	M60x2,0	66
NHT-208A6	210	107	170	5	133,35	52	6xM12	17	20	41,8	34	7,5	31,5	15,5	32	12	20,5	M60x2,5	66



Dreibacken-Kraftspannfutter ohne Durchgangsbohrung - 1,5 x 60°

Three-jaw power chucks without bore - 1,5 x 60°

1

1.10

Strong AUTO

Zylindrische Aufnahme, ohne Durchgangsbohrung
Centre mount, without bore

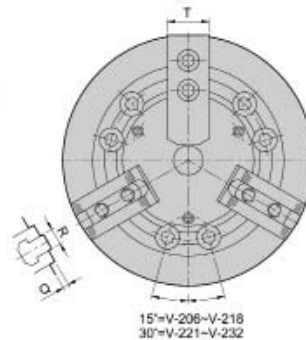
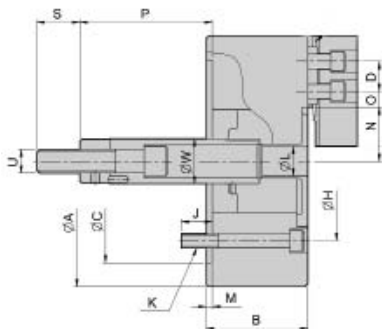

Stahl / Steel

Typ / Type	Backenhub / Jaw stroke mm	Zugrohrhub / Plunger stroke mm	Spannbereich max. / Gripping max. mm	Spannbereich min. / Gripping min. mm	Max. Betätigungs-kraft / Max. pull force (kN)	Max. Spannkraft / Max. gripping force (kN)	Max. Betätigungs-druck / Max. operating pressure (kN)	Trägheitsmoment / Moment of inertia (kgf-m ²)	Passende harte Aufsatzbacken / Matching hard jaws	Passende weiche Aufsatzbacken / Matching soft jaws	Passender Zylinder / Matching Cylinder	Max. Drehzahl / Max. speed (rpm)	kg	Art.-Nr. / Order no.
V-206	9,2	20	165	18	18	51,5	26,5	0,045	HJ06	HC06	MS105C	5200	12	● 29-V-206
V-208	9,7	21	210	12	25	75	25,5	0,137	HJ08	HC08	MS125C	4500	23	● 29-V-208
V-210	8,8	25	254	16	29	108	28,6	0,3	HJ10	HC10	MS125C	4000	34,5	● 29-V-210
V-212	10,5	30	304	18	41	156	27,5	0,72	HJ12-1	HC12-1	MS150C	3300	59,5	● 29-V-212
V-215	16	35	381	68	82	249	32,6	1,8	HJ15-1	HC15-1	MS200C	3000	101	○ 29-V-215
V-218	16	35	450	130	82	249	32,6	2,9	HJ15-1	HC15-1	MS200C	2700	134	○ 29-V-218
V-224*	16	35	573	138	82	273	32,6	7	HJ24-1	HC24-1	MS200C	1760	220	○ 29-V-224

* Verzahnung / serration 3 x 60°

Inkl. je 1 Satz Grund- und weiche Aufsatzbacken, Befestigungsschrauben
Incl. 1 set each of hardened base jaws and soft top jaws, fixation screws

Typ / Type	A mm	B mm	C(H6) mm	M mm	H mm	L mm	K mm	J mm	D mm	N max. mm	Q max. mm	Q min. mm	P max. mm	P min. mm	T mm	R mm	S mm	U max	W mm
V-206	165	74	140	5	104,78	21	6-M10	14	20	38,7	15,25	9,25	104,6	84,6	31	12	36	M16x2,0	34
V-208	210	85	170	5	133,35	25	6-M12	20	25	46,75	22,25	11,75	132	111	35	14	36	M20x2,5	38
V-210	254	89	220	5	171,45	34	6-M16	18	30	51,1	30,75	11,25	158	133	40	16	36	M20x2,5	45
V-212	304	106	220	6	171,45	34	6-M16	22	30	61	48,75	12,75	163	133	50	18	36	M20x2,5	50
V-215	381	114	300	6	235	-	6-M20	29	43	77,5	50,25	23,25	104	69	50	25,5	55	M30x3,5	60
V-218	450	114	300	6	235	-	6-M20	29	43	108	50,25	23,23	92	57	50	25,5	55	M30x3,5	60
V-224	610	125	380	6	330,2	-	6-M24	31	60	125	93,5	24,5	97	62	65	25	55	M30x3,5	60



Dreibacken-Kraftspannfutter ohne Durchgangsbohrung - 1,5 x 60°

Three-jaw power chucks without bore - 1,5 x 60°



DIN 55026, ohne Durchgangsbohrung
According to DIN 55026, without bore

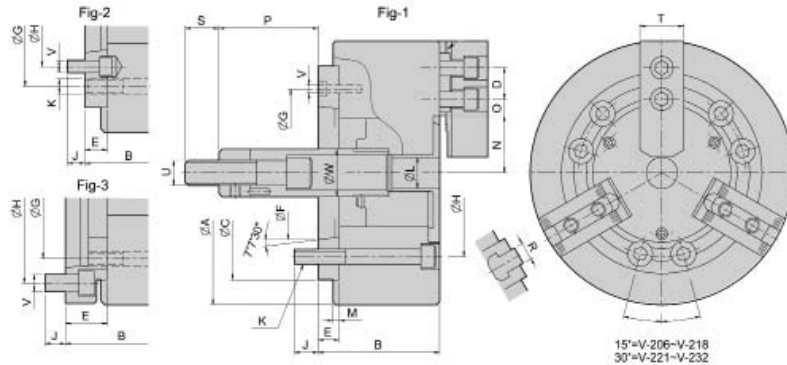

Stahl / Steel

Typ / Type	Fig	Backenhub / Jaw stroke mm	Zugrohrhub / Plunger stroke mm	Max. Betätigungs-kraft / Max. pull force (kN)	Max. Spannkraft / Max. gripping force (kN)	Max. Betätigungs-druck / Max. operating pressure (kN)	Trägheitsmoment / Moment of inertia (kN x m2)	Passende harte Aufsatzbacken / Matching hard jaws	Passende weiche Aufsatzbacken / Matching soft jaws	Passender Zylinder / Matching Cylinder	Max. Drehzahl / Max. speed (rpm)	kg	Art.-Nr. / Order no.
V-206A5	1	9,2	20	18	52,49	26,5	0,05	HJ06	HC06	MS105C	5000	13,2	29-V-206A5
V-206A6	3	9,2	20	18	52,49	26,5	0,059	HJ06	HC06	MS105C	5000	15,8	29-V-206A6
V-208A5	2	9,7	21	25	75	25,5	0,154	HJ08	HC08	MS125C	4500	25,8	29-V-208A5
V-208A6	1	9,7	21	25	75	25,5	0,149	HJ08	HC08	MS125C	4500	25	29-V-208A6
V-210A6	2	8,8	25	29	108	28,6	0,35	HJ10	HC10	MS125C	4000	40,5	29-V-210A6
V-210A8	1	8,8	25	29	108	28,6	0,33	HJ10	HC10	MS125C	4000	37,5	29-V-210A8
V-212A8	1	10,5	30	41	156	27,5	0,75	HJ12-1	HC12-1	MS150C	3300	62,5	29-V-212A8
V-212A11	3	10,5	30	41	156	27,5	0,888	HJ12-1	HC12-1	MS150C	3300	72,9	29-V-212A11
V-215A8	2	16	35	82	249	32,6	2,05	HJ15-1	HC15-1	MS200C	3000	115	29-V-215A8
V-215A11	1	16	35	82	249	32,6	1,92	HJ15-1	HC15-1	MS200C	3000	108	29-V-215A11
V-218A8	2	16	35	82	249	32,6	3,35	HJ15-1	HC15-1	MS200C	2700	134	29-V-218A8
V-218A11	1	16	35	82	249	32,6	3,05	HJ15-1	HC15-1	MS200C	2700	141	29-V-218A11
V-224A11*	2	16	35	82	249	32,6	7,6	HJ24-1	HC24-1	MS200C	1760	239	29-V-224A11
V-224A15*	1	16	35	82	273	32,6	7,38	HJ24-1	HC24-1	MS200C	1760	232	29-V-224A15

* Verzahnung / serration 3 x 60°
Inkl. je 1 Satz Grund- und weiche Aufsatzbacken, Befestigungsschrauben
Incl. 1 set each of hardened base jaws and soft top jaws, fixation screws

Typ / Type	A mm	B mm	H mm	D mm	C mm	K mm	M mm	J mm	L mm	E mm	F mm	G mm	O max.	O min.	P max.	P min.	S mm	U max	W mm	N max.	T mm	R mm	V
V-206A5	165	84	104,78	20	140	6-M10	5	14	21	15	82,563	116	14,75	7,25	89,6	69,6	36	M16x2,0	34	38,7	31	12	3-M6
V-206A6	165	104	133,35	20	140	6-M10	5	16	21	35	106,375	104,78	14,75	7,25	69,6	49,6	36	M16x2,0	34	38,7	31	12	6-M12
V-208A5	210	103	104,78	25	170	6-M12	5	13	25	23	82,563	133,35	22,25	10,25	109	88	36	M20x2,5	38	46,8	35	14	6-M10
V-208A6	210	97	133,35	25	170	6-M12	5	18	25	17	106,375	150	22,25	11,75	115	94	36	M20x2,5	38	46,3	35	14	3-M6
V-210A6	254	109	133,35	30	220	6-M16	5	18	34	25	106,375	171,45	30,75	11,25	133	108	36	M20x2,5	45	51,1	40	16	6-M12
V-210A8	254	102	171,45	30	220	6-M16	5	25	34	18	139,719	190	30,75	11,25	140	115	36	M20x2,5	45	51,1	40	16	6-M8
V-212A8	304	118	171,45	30	220	6-M16	6	25	34	18	139,719	190	48,75	12,75	145	115	36	M20x2,5	50	61	50	18	6-M8
V-212A11	304	150	235	30	220	6-M16	6	28	34	50	196,869	171,45	48,75	12,75	113	83	36	M20x2,5	50	61	50	18	6-M20
V-215A8	381	141	171,45	43	300	6-M20	6	24	-	33	139,719	235	50,25	23,25	71	36	55	M30x3,5	60	77,5	50	25,5	6-M16
V-215A11	381	130	235	43	300	6-M20	6	32	-	22	196,869	260	50,25	23,25	82	47	55	M30x3,5	60	77,5	50	25,5	3-M10
V-218A8	450	141	171,45	43	300	6-M20	6	24	-	33	139,719	235	50,25	23,25	59	24	50	M30x3,5	60	108	62	25,5	6-M16
V-218A11	450	130	235	43	300	6-M20	6	32	-	22	196,869	260	50,25	23,25	70	35	55	M30x3,5	60	108	50	25,5	3-M10
V-224A11	610	146	235	60	380	6-M24	6	28	-	27	196,869	330,2	93,5	24,5	70	35	55	M30x3,5	60	125	65	25	6-M20
V-224A15	610	146	330,2	60	380	6-M24	6	34	-	27	285,775	330,2	93,5	24,5	70	35	55	M30x3,5	60	125	65	25	3-M12



Dreibacken-Kraftspannfutter mit Durchgangsbohrung - 1,5 x 60°

Three-jaw power chucks with bore - 1,5 x 60°



Zylindrische Aufnahme, mit Durchgangsbohrung

Centre mount, with bore



Stahl / Steel

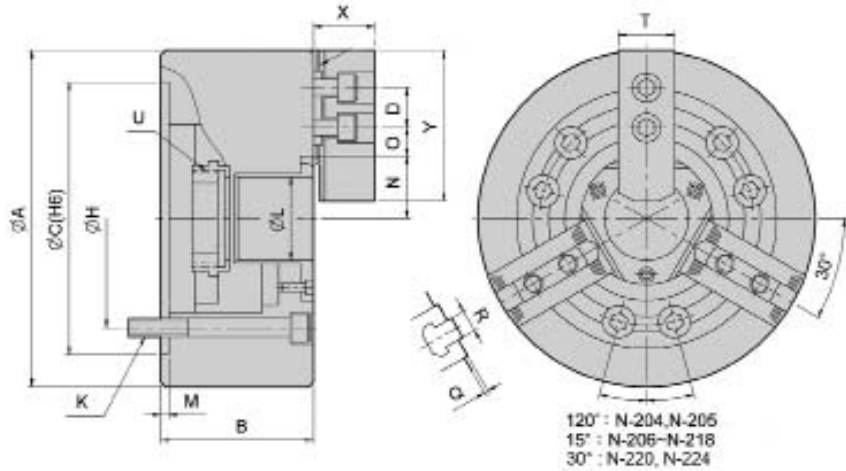

120° : N-204, N-205
15° : N-206-N-218
30° : N-220, N-224

Typ / Type	Backenhub / Jaw stroke mm	Zugrohrhub / Plunger stroke mm	Max. Betätigungs-kraft / Max. Draw bar pull force (kN)	Max. Spannkraft / Max. gripping force (kN)	Max. Betätigungs-druck / Max. operating pressure (kN)	Trägheitsmoment / Moment of inertia (kgf-m ²)	Passende harte Aufsatzbacken / Matching hard jaws	Passende weiche Aufsatzbacken / Matching soft jaws	Passender Zylinder / Matching Cylinder	Max. Drehzahl / Max. speed (rpm)	kg	Art.-Nr. / Order no.
N-204	5,4	10	14	28,50	31,6	0,007	HJ05	HC04	M0928	8000	4	● 29-N-204
N-205	5,4	10	17,50	36	28,5	0,018	HJ05	HC05	M1036	7000	7	● 29-N-205
N-206	5,5	12	22	57	28,5	0,057	HJ06	HC06	M1246	6000	13,5	● 29-N-206
N-208	7,4	16	34,89	89	26,5	0,17	HJ08	HC08	M1552	4900	23	● 29-N-208
N-210	8,8	19	43	111	27,5	0,315	HJ10	HC10	M1875	4200	35	● 29-N-210
N-212	10,6	23	57	147	27,5	0,737	HJ12	HC12	M2091	3300	56,5	● 29-N-212
N-215	10,6	23	71	180	23,5	2,27	HJ15	HC15	M2511	2500	111	● 29-N-215
N-218	10,6	23	71	180	23,5	3,55	HJ15	HC15	M2511	2000	164	○ 29-N-218
N-220*	10,6	23	90	234	30,6	6,5	HJ24-1	HC24-1	ML2816	1800	190	○ 29-N-220
N-224*	12	26	90	234	26,5	14,8	HJ24-1	HC24-1	ML3320	1400	270	○ 29-N-224

* Verzahnung / serration 3 x 60°

Inkl. je 1 Satz Grund- und weiche Aufsatzbacken, Befestigungsschrauben, Zugrohradapterrohling
Incl. 1 set each of hardened base jaws and soft top jaws, fixation screws, blank draw tube adaptor

Typ / Type	A mm	B mm	C(H6) mm	H mm	M mm	L mm	U max.	T mm	Y mm	X mm	D mm	N max. mm	O max. mm	O min. mm	R mm	K mm
N-204	110	59	85	70,6	4	26	M32x1,5	23	49,5	24	14	23,2	13,75	6,75	10	3-M10x60
N-205	135	60	110	82,55	4	33	M40x1,5	23	54	26	14	26,5	19,75	7,75	10	3-M10x60
N-206	169	81	140	104,78	5	45	M55x2	32	73	37	20	32	22,75	9,25	12	6-M10x80
N-208	210	91	170	133,35	5	52	M60x2	37	95	38	25	38,7	29,75	14,75	14	6-M12x90
N-210	254	100	220	171,45	5	75	M85x2	42	110	43	30	51	33,75	14,25	16	6-M16x100
N-212	304	110	220	171,45	6	91	M100x2	52	130	51	30	61,3	45,75	15,75	21	6-M16x110
N-215	381	133	300	235	6	117,5	M130x2	62	165	66	43	82	46,75	13,75	22	6-M20x135
N-218	450	133	300	235	6	117,5	M130x2	62	165	66	43	82	79,25	13,75	22	6-M20x135
N-220	510	134	380	330,2	6	180	M190x3	65	180	73	60	112,5	60,5	24,5	25	6-M24x135
N-224	610	147	520	463,6	6	205	M215x3	65	180	73	60	139,9	87,5	24,5	25	6-M20x150

Backen kompatibel zu Kitagawa Typ B200
Jaws compatible with Kitagawa type B200



Dreibacken-Kraftspannfutter mit Durchgangsbohrung - 1,5 x 60°

Three-jaw power chucks with bore - 1,5 x 60°



DIN 55026, mit Durchgangsbohrung
According to DIN 55026, with bore

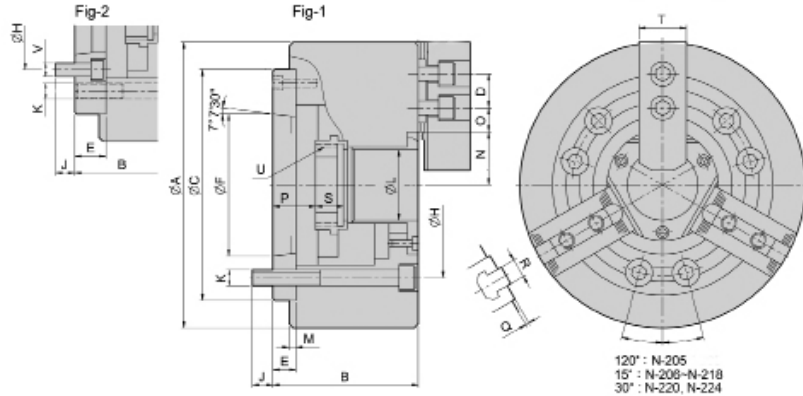

Stahl / Steel

Typ / Type	Fig	Backenhub / Jaw stroke mm	Zugrohrhub / Plunger stroke mm	Max. Betätigungs-kraft / Max. Draw bar pull force (kN)	Max. Spannkraft / Max. gripping force (kN)	Max. Betätigungs-druck / Max. operating pressure (kN)	Passende harte Aufsatzbacken / Matching hard jaws	Passende weiche Aufsatzbacken / Matching soft jaws	Passender Zylinder / Matching Cylinder	Max. Drehzahl / Max. speed (rpm)	kg	Art.-Nr. / Order no.
N-205A4	1	5,4	10	17,50	36	28,5	HJ05	HC05	M1036	7000	7,8	29-N-205A4
N-205A5	3	5,4	10	17,50	36	28,5	HJ05	HC05	M1036	7000	9,0	29-N-205A5
N-206A4	2	5,5	12	22	57	28,5	HJ06	HC06	M1246	6000	15,5	29-N-206A4
N-206A5	1	5,5	12	22	57	27,5	HJ06	HC06	M1246	6000	14,7	29-N-206A5
N-208A5	2	7,4	16	34,89	89	26,5	HJ08	HC08	M1552	4900	25,8	29-N-208A5
N-208A6	1	7,4	16	34,89	89	26,5	HJ08	HC08	M1552	4900	25	29-N-208A6
N-210A6	2	8,8	19	43	111	27,5	HJ10	HC10	M1875	4200	41	29-N-210A6
N-210A8	1	8,8	19	43	111	27,5	HJ10	HC10	M1875	4200	38	29-N-210A8
N-212A6	2	10,6	23	57	147	27,5	HJ12	HC12	M2091	3300	62,5	29-N-212A6
N-212A8	1	10,6	23	57	147	27,5	HJ12	HC12	M2091	3300	59,5	29-N-212A8
N-215A8	2	10,6	23	71	180	23,5	HJ15	HC15	M2511	2500	125	29-N-215A8
N-215A11	1	10,6	23	71	180	23,5	HJ15	HC15	M2511	2500	118	29-N-215A11
N-218A8	2	10,6	23	71	180	23,5	HJ15	HC15	M2511	2000	178	29-N-218A8
N-218A11	1	10,6	23	71	180	23,5	HJ15	HC15	M2511	2000	171	29-N-218A11
N-220A11*	2	10,6	23	90	234	30,6	HJ24-1	HC24-1	ML2816	1800	215	29-N-220A11
N-224A11*	2	12	26	90	234	26,5	HJ24-1	HC24-1	ML3320	1400	332	29-N-224A11

* Verzahnung / serration 3 x 60°

Inkl. je 1 Satz Grund- und weiche Aufsatzbacken, Befestigungsschrauben, Zugrohradapterrohling
Incl. 1 set each of hardened base jaws and soft top jaws, fixation screws, blank draw tube adaptor

Typ / Type	A mm	B mm	D mm	E mm	F mm	C mm	H mm	J mm	K	L mm	M mm	N max.	O max.	O min.	P max.	P min.	Q mm	R mm	S mm	T mm	U max.	V
N-205A4	135	71	14	15	63,513	110	82,55	15,5	3xM10	33	4	26,5	19,75	7,75	16	6	2	10	20	23	M40x1,5	3xM6
N-205A5	135	88	14	32	82,563	110	104,78	14	3xM10	33	4	26,5	19,75	7,75	33	23	2	12	20	25	M40x1,5	6xM10
N-206A4	169	96	20	20	63,513	140	82,55	16	6xM10	45	5	32	22,75	9,25	26	14	2	12	19	31	M55x2,0	6xM10
N-206A5	169	91	20	15	82,563	140	104,78	16	6xM10	45	5	32	22,75	9,25	26	14	2	12	19	32	M55x2,0	6xM10
N-208A5	210	109	25	23	82,563	170	104,78	13	6xM12	52	5	38,7	29,75	14,75	37,5	21,5	2	14	20,5	37	M60x2,0	6xM12
N-208A6	210	103	25	17	106,375	170	133,35	18	6xM12	52	5	38,7	29,75	14,75	31,5	15,5	2	14	20,5	37	M60x2,0	6xM12
N-210A6	254	120	30	25	106,375	220	133,35	18	6xM16	75	5	51	33,75	14,25	33,5	14,5	2	16	25	42	M85x2,0	6xM16
N-210A8	254	113	30	18	139,719	220	171,45	24	6xM16	75	5	51	33,75	14,25	26,5	7,5	2	16	25	42	M85x2,0	6xM16
N-212A6	304	129	30	25	106,375	220	133,35	18	6xM16	91	6	61,3	45,75	15,75	33	10	2	21	28	50	M100x2,0	6xM12
N-212A8	304	122	30	18	139,719	220	171,45	25	6xM16	91	6	61,3	45,75	15,75	26	3	2	21	28	50	M100x2,0	3xM8
N-215A8	381	160	43	33	139,719	300	171,45	24	6xM20	117,5	6	82	46,75	13,75	40	17	5	24	43	62	M130x2,0	6xM20
N-215A11	381	149	43	22	196,869	300	235	28	6xM20	117,5	6	82	46,75	13,75	29	6	5	24	43	62	M130x2,0	6xM20
N-218A8	450	160	43	33	139,719	300	171,45	24	6xM20	117,5	6	82	79,25	13,75	40	17	5	22	43	62	M130x2,0	6xM20
N-218A11	450	149	43	22	196,869	300	235	28	6xM20	117,5	6	82	79,25	13,75	29	6	5	22	43	62	M130x2,0	6xM20
N-220A11	510	169	60	41	196,869	380	235	30	6xM24	180	6	112,5	60,5	24,5	52	29	5	25	38	65	M190x3,0	6xM20
N-224A11	610	186	60	45	196,869	520	235	28	6xM24	205	6	139,9	87,5	24,5	61	35	5	25	38	65	M215x3,0	6xM20



Lagerstandard / in stock
innerhalb weniger Tage / within a few days
auf Anfrage / on request
auslaufende Größe / as stock lasts

Dreibacken-Kraftspannfutter mit großer Durchgangsbohrung - 1,5 x 60° Three-jaw power chucks with big bore - 1,5 x 60°

1
1.10



DIN 55026, mit großer Durchgangsbohrung
According to DIN 55026, with big bore

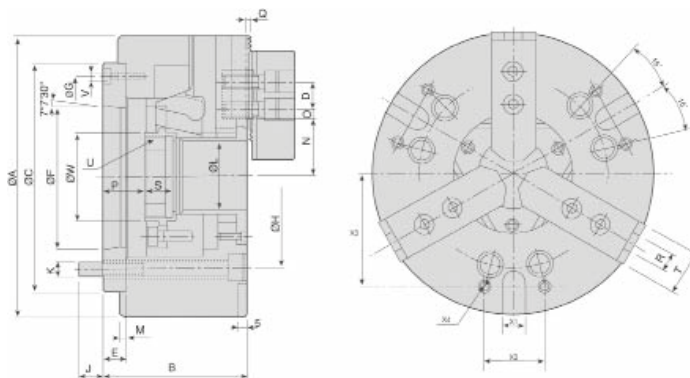

Stahl / Steel

Typ / Type	Backenhub / Jaw stroke mm	Zugrohrhub / Plunger stroke mm	Max. Betätigungskraft / Max. Draw bar pull force (kN)	Max. Spannkraft / Max. gripping force (kN)	Max. Betätigungsdruck / Max. operating pressure (kN)	Passende harte Aufsatzbacken / Matching hard jaws	Passende weiche Aufsatzbacken / Matching soft jaws	Passender Zylinder / Matching Cylinder	Max. Drehzahl / Max. speed (rpm)	kg	Art.-Nr. / Order no.
NB-206A5	6	13	22	57	18,4	HJ06	HC06	M1552	6000	14,5	● 29-NB-206A5
NB-208A6	7,4	16	34,89	89	20,5	HJ08	HC08	M1868	4600	24	● 29-NB-208A6
NB-210A8	8,8	19	43	111	27,5	HJ10	HC10	M1878	4200	37,4	● 29-NB-210A8
NB-212A8	8,8	19	43	111	27,5	HJ10	HC10	M1878	4200	37,4	○ 29-NB-212A8
NB-212A11	10,6	23	57	147	20,5	HJ12	HC12	M2511	3200	65	○ 29-NB-212A11
NB-215A15	10,6	23	71	180	25,5	HJ15	HC15	M2816	2500	130	○ 29-NB-215A15
NB-218A15	10,6	23	71	180	25,5	HJ15	HC15	M2816	2000	160	○ 29-NB-218A15

Inkl. je 1 Satz Grund- und weiche Aufsatzbacken, Befestigungsschrauben, Zugrohradapterrohling
Incl. 1 set each of hardened base jaws and soft top jaws, fixation screws, blank draw tube adaptor

Typ / Type	A mm	B mm	C mm	D mm	E mm	F mm	G mm	H mm	J mm	K	L mm	M mm	O max.	O min.	P max.	P min.	Q mm	R mm	S max.	T min.	U max	V	W mm
NB-206A5	170	97	140	20	22	82,563	116	104,78	16	6xM10	52	5	18,25	9,25	30	17	2	12	16	32	M60x2,0	3xM6	60
NB-208A6	210	103	170	25	17	106,375	150	133,35	19,5	6xM12	66	5	23,75	11,75	31,5	15,5	2	14	20	37	M74x2,0	3xM6	80
NB-210A8	254	113	220	30	24	139,719	190	171,45	24	6xM16	78	5	33,75	14,25	26,5	7,5	2	16	25	42	M87x2,0	6xM8	94
NB-212A8	254	118	220	30	18	139,719	190	171,45	24	6xM16	122	5	33,75	14,25	26,5	7,5	2	16	25	42	M87x2,0	6xM8	94
NB-212A11	304	134	300	30	22	196,869	260	235	28	6xM20	122	6	36,25	12,75	42	19	2	21	28	52	M135x2	3xM10	143
NB-215A15	405	154	380	43	27	285,775	330	330,2	33	6xM24	142	6	45,25	15,25	34	11	5	22	43	62	M155x2	3xM12	164
NB-218A15	457	154	380	43	27	285,775	330	330,2	33	6xM24	166	6	63,25	18,25	34	11	5	22	43	62	M180x3	3xM12	189

Backen kompatibel zu Kitagawa Typ BB200
Jaws compatible with Kitagawa type BB200



Kraftspannfutter, Backen und Zubehör / Power chucks, jaws and accessories

Vierbacken-Kraftspannfutter mit Durchgangsbohrung - 1,5 x 60°

Four-jaw power chucks with bore - 1,5 x 60°



Zylindrische Aufnahme, mit Durchgangsbohrung

Centre mount, with bore



Stahl / Steel

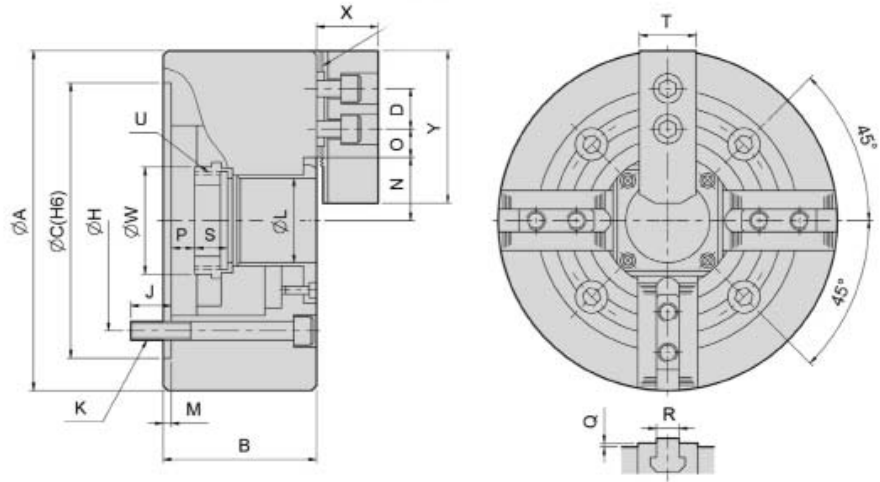

Typ / Type	Backenhub / Jaw stroke mm	Zugrohrhub / Plunger stroke mm	Max. Betätigungskraft / Max. Draw bar pull force (kN)	Max. Spannkraft / Max. gripping force (kN)	Max. Betätigungsdruck / Max. operating pressure (kN)	Trägheitsmoment / Moment of inertia (kgf-m ²)	Passende harte Aufsatzbacken / Matching hard jaws	Passende weiche Aufsatzbacken / Matching soft jaws	Passender Zylinder / Matching Cylinder	Max. Drehzahl / Max. speed (rpm)	kg	Art.-Nr. / Order no.
NIT-206	5,5	12	22	57	28,5	0,058	HJ06	HC06	M1546	4500	14	29-NIT-206
NIT-208	7,4	16	34,89	89	26,5	0,177	HJ08	HC08	M1552	3600	24	29-NIT-208
NIT-210	8,8	19	43	111	27,5	0,324	HJ10	HC10	M1875	3200	36	29-NIT-210
NIT-212	10,6	23	57	147	27,5	0,763	HJ12	HC12	M2091	2700	58,5	29-NIT-212
NIT-215	10,6	23	71	180	23,5	2,331	HJ15	HC15	M2511	1900	114	29-NIT-215
NIT-218	10,6	23	71	180	23,5	3,798	HJ15	HC15	M2511	1500	140	29-NIT-218
NIT-224*	12	26	90	234	26,5	15,2	HJ24-1	HC24-1	ML3320	1000	284	29-NIT-224

* Verzahnung / serration 3 x 60°
 Inkl. je 1 Satz Grund- und weiche Aufsatzbacken, Befestigungsschrauben, Zugrohradapterrohling
 Incl. 1 set each of hardened base jaws and soft top jaws, fixation screws, blank draw tube adaptor

Typ / Type	A mm	B mm	C(H6) mm	H mm	M mm	L mm	U max.	T mm	Y mm	X mm	D mm	N max. mm	O max. mm	O min. mm	R mm	K mm
206	169	81	140	104,78	5	45	M55x2	31	73	37	20	32	22,75	9,25	12	4-M10x80
208	210	91	170	133,35	5	52	M60x2	35	95	38	25	38,7	29,75	14,75	14	4-M12x90
210	254	100	220	171,45	5	75	M85x2	40	110	43	30	51	33,75	14,25	16	4-M16x100
212	304	110	220	171,45	6	91	M100x2	50	130	51	30	61,3	45,75	15,75	21	4-M16x110
215	381	133	300	235	6	117,5	M130x2	62	165	66	43	82	42,25	16,75	22	4-M20x135
218	450	133	300	235	6	117,5	M130x2	62	165	66	43	82	79,75	15,25	22	4-M20x135
224	610	147	520	463,6	6	205	M215x3	65	180	73	60	139,9	87,5	24,5	25	8-M24x150



Vierbacken-Kraftspannfutter mit Durchgangsbohrung - 1,5 x 60°

Four-jaw power chucks with bore - 1,5 x 60°

Strong AUTO

DIN 55026, mit Durchgangsbohrung
According to DIN 55026, with bore

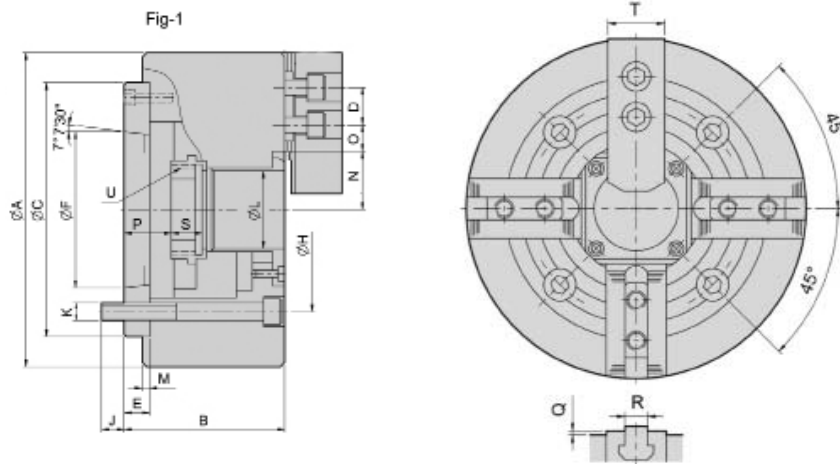

Stahl / Steel

Typ / Type	Backenhub / Jaw stroke mm	Zugrohrhub / Plunger stroke mm	Max. Betätigungskraft / Max. Draw bar pull force (kN)	Max. Spannkraft / Max. gripping force (kN)	Max. Betätigungsdruck / Max. operating pressure (kN)	Trägheitsmoment / Moment of inertia (kgf-m ²)	Passende harte Aufsatzbacken / Matching hard jaws	Passende weiche Aufsatzbacken / Matching soft jaws	Passender Zylinder / Matching Cylinder	Max. Drehzahl / Max. speed (rpm)	kg	Art.-Nr. / Order no.
NIT-206A5	5,5	12	22	57	28,5	0,058	HJ06	HC06	M1246	4500	13,7	29-NIT-206A5
NIT-208A5	7,4	16	34,40	88	26,5	0,177	HJ08	HC08	M1552	3600	24	29-NIT-208A5
NIT-208A6	7,4	16	34,40	88	26,5	0,177	HJ08	HC08	M1552	3600	24	29-NIT-208A6
NIT-210A6	8,8	19	43	111	27,5	0,324	HJ10	HC10	M1875	3200	36	29-NIT-210A6
NIT-210A8	8,8	19	43	111	27,5	0,324	HJ10	HC10	M1875	3200	36	29-NIT-210A8
NIT-212A8	10,6	23	57	147	27,5	0,763	HJ12	HC12	M2091	2700	58,5	29-NIT-212A8
NIT-215A8	10,6	23	71	180	23,5	2,331	HJ15	HC15	M2511	1900	114	29-NIT-215A8
NIT-215A11	10,6	23	71	180	23,5	2,331	HJ15	HC15	M2511	1900	114	29-NIT-215A11

Inkl. je 1 Satz Grund- und weiche Aufsatzbacken, Befestigungsschrauben, Zugrohradapterrohling
Incl. 1 set each of hardened base jaws and soft top jaws, fixation screws, blank draw tube adaptor

Typ / Type	A mm	B mm	D mm	E mm	F mm	C mm	H mm	J mm	K	L mm	M mm	N max.	O max.	O min.	P max.	P min.	Q mm	R mm	S mm	T mm	U max.	W mm
206A5	169	91	15	15	82,563	140	104,78	16	6xM10	45	5	32	22,75	9,25	26	14	2	12	19	32	M55x2,0	60
208A5	210	109	25	23	82,563	170	104,78	13	6xM12	52	5	38,7	29,75	14,75	37,5	21,5	2	14	20,5	37	M60x2,0	66
208A6	210	103	25	17	106,375	170	133,35	18	6xM12	52	5	38,7	29,75	14,75	31,5	15,5	2	14	20,5	37	M60x2,0	66
210A6	254	120	30	25	106,375	220	133,35	18	6xM16	75	5	51	33,75	14,25	33,5	14,5	2	16	25	42	M85x2,0	94
210A8	254	113	30	18	139,719	220	171,45	24	6xM16	75	5	51	33,75	14,25	26,5	7,5	2	16	25	42	M85x2,0	94
212A8	304	122	30	18	139,719	220	171,45	25	6xM16	91	6	61,3	45,75	15,75	26	3	2	21	28	52	M100x2,0	108
215A8	381	160	43	33	139,719	300	171,45	24	6xM20	117,5	6	82	46,75	13,75	40	17	5	24	43	62	M130x2,0	139
215A11	381	149	43	22	196,869	300	235	28	6xM20	117,5	6	82	46,75	13,75	29	6	5	24	43	62	M130x2,0	139



Großes Dreibacken-Keilstangen-Kraftspannfutter ohne Durchgangsbohrung - Kreuzversatz

Large three-jaw wedge type power chuck, without bore - cross tenon



Zylindrische Aufnahme, ohne Durchgangsbohrung Centre mount, without bore

- Grundbacken mit manuell einstellbarem Radialspiel
- für den vertikalen Einsatz geeignet
- master jaw with manual radial setting function
- suitable for vertical lathes

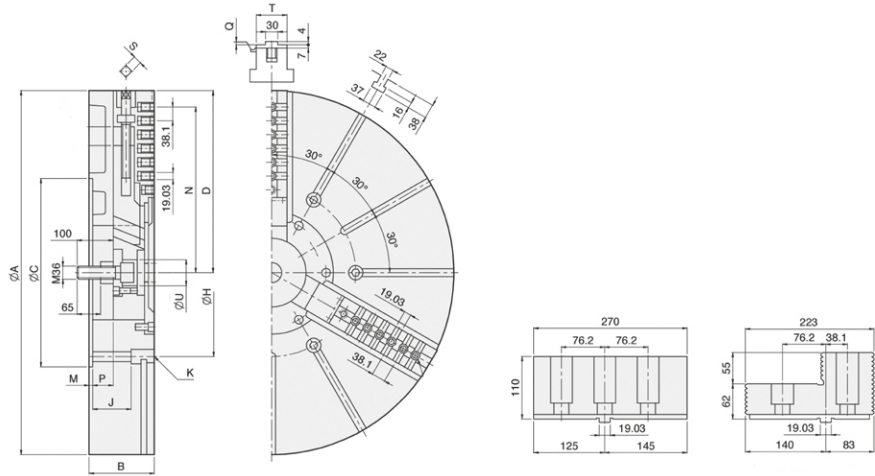

Stahl / Steel

Typ / Type	Zugrohrhub / Plunger stroke mm	Backenhub / Jaw stroke mm	Max. Betätigungskraft / Max. Draw bar pull force (kN)	Max. Spannkraft / Max. gripping force (kN)	Max. Betätigungsdruck / Max. operating pressure (kN)	Trägheitsmoment / Moment of inertia (kgf-m ²)	Passende harte Aufsatzbacken / Matching hard jaws	Passende weiche Aufsatzbacken / Matching soft jaws	Passender Zylinder / Matching Cylinder	Max. Drehzahl / Max. speed (rpm)	kg	Art.-Nr. / Order no.
V-240	57	23+30	180	320	42,8	0,082	HJ40-1	HC40-1	MS250C	630	645	29-V-240
V-250	57	23+30	180	320	42,8	0,168	HJ40-1	HC40-1	MS250C	500	890	29-V-250
V-263	60	24+40	200	360	46,9	0,548	HJ40-1	HC40-1	MS250C	400	1800	29-V-263

Inkl. 1 Satz Grundbacken, Befestigungsschrauben
Incl. 1 set of hardened base jaws, fixation screws

Typ / Type	A mm	B mm	C mm	D max	H mm	J mm	K	M mm	N max.	P max.	P min.	Q mm	S mm	T mm	U mm
V-240	1005	180	520	502	463,6	108	M24	8	457	59	2	4	19	85	72
V-250	1250	180	520	623	463,6	108	M24	8	563	59	2	4	19	85	72
V-263	1600	220	720	796	647,6	144	M30	8	738	82	22	6	22	110	72

Auch als 4- und 6-Backen Ausführung auf Anfrage lieferbar
Also available as 4- or 6-jaw type upon request



Pneumatische Kraftspannfutter

Pneumatic power chucks

Strong AUTO

Pneumatische Vorderendfutter mit zylindrischer Aufnahme

Pneumatic power chucks with centre mount

- mit integriertem Pneumatikzylinder
- mit Eil- und Spannhub
- Spanndruck- und Spannhubkontrolle
- with built-in pneumatic cylinder
- fast and clamping jaw stroke
- clamping pressure and stroke control



Stahl / Steel

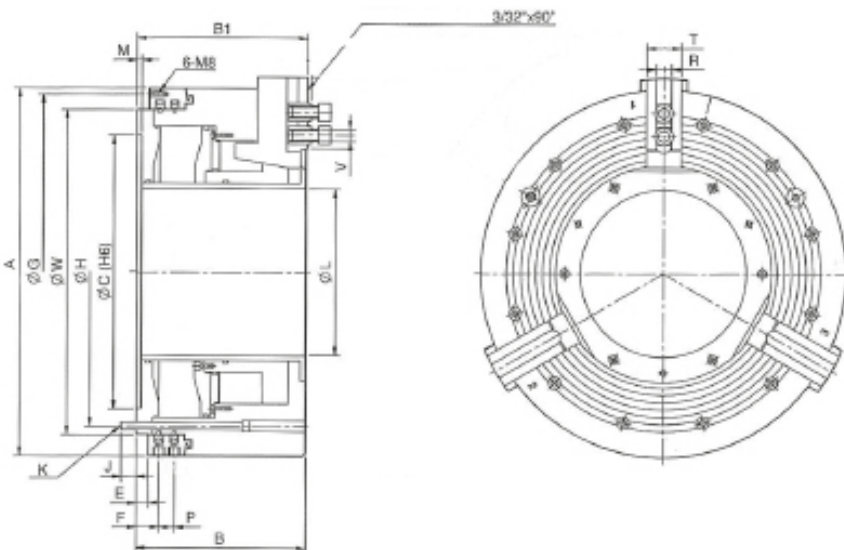

Typ / Type	A mm	Durchgangsbohrung / Through-Hole mm	Gesamtbackenhub / Total stroke jaw mm	Spannhub / Clamping stroke mm	Zylinderfläche / Piston Area (cm ²)	Betriebsdruck min.-max. / Operating Pressure min.-max. (bar)	Max. Spannkraft / Max. gripping force (kN)	Max. Drehzahl / Max. speed (rpm)	Trägheitsmoment / Moment of inertia (kgf-m ²)	Luftverbrauch / Air consumption	kg	Art.-Nr. / Order no.
PBES-605*	605	275	25,4	8,5	954	2-10	180	1100	20,6	39,5	360	29-PBES-605
PBES-850*	850	375	25,4	12	1342	2-10	250	750	110	68	980	29-PBES-850

* Verzahnung / serration 3/32" x 90°

Inkl. je 1 Satz Grund- und weiche Aufsatzbacken
Incl. 1 set each of hardened base jaws and soft top jaws

Typ / Type	B mm	B1 mm	C mm	E mm	F mm	G mm	H mm	J mm	K	L mm	M mm
PBES-605	280	282	450	20	37	585	508	25	12-M12	275	8
PBES-850	352	354	700	25	44,5	830	745	30	12-M16	375	8

Typ / Type	P max.	R mm	T mm	V mm	W mm
PBES-605	26	25,5	57	M20	535
PBES-850	33	30	75	M24	775

Ersatzbacken auf Anfrage lieferbar
Spare jaws available upon request

Flansche nach DIN 55026 für Kraftspannfutter Adaptor plates according to DIN 55026 for power chucks

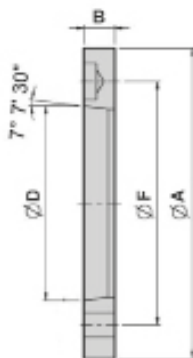

Stahl / Steel

Spindel / Spindle	A mm	B mm	D mm	F mm	Passende Futter / Matching chucks	Art.-Nr. / Order no.
A4	110	15	63,513	82,55	N-205	● 29-FN-205/4
A4	110	15	63,513	82,55	NT-205	○ 29-FNT-205/4
A5	140	15	82,563	104,78	N-206, NB-306, V-206	● 29-FN-206/5
A5	140	15	82,563	104,78	NT-206, VT-206	○ 29-FNT-206/5
A5	140	15	82,563	104,78	NIT-206	○ 29-FNIT-206/5
A6	170	17	106,375	133,35	N-208, NB-208, V-208	● 29-FN-208/6
A6	170	17	106,375	133,35	NT-208, VT-208	○ 29-FNT-208/6
A6	170	17	106,375	133,35	NIT-208	○ 29-FNIT-208/6
A6	170	17	106,375	133,35	NHT-208	○ 29-FNHT-208/6
A8	220	18	139,719	171,45	N-210, N-212, NB-210, V-210, V-212	● 29-FN-210/8
A8	220	18	139,719	171,45	NT-210, NT-212, VT-210, VT-212	○ 29-FNT-210/8
A8	220	18	139,719	171,45	NIT-210, NIT-212, VIT-212	○ 29-FNIT-210/8
A11	300	22	196,869	235	N-215, N-218, NB-212, V-215, V-218	○ 29-FN-215/11
A11	300	22	196,869	235	NT-215, VT-215	○ 29-FNT-215/11
A11	300	22	196,869	235	NIT-215, VIT-218	○ 29-FNIT-215/11
A15	380	27	285,775	330,2	N-220, V-221, V-224, V-232, NB-215, NB-218	○ 29-FN-220/15
A15	380	27	285,775	330,2	VIT-224, VIT-232	○ 29-FVIT-224/15
A20	520	25	412,775	463,6	N-224, N-232, V-240, V-250	○ 29-FN-224/20



Fertiger Zugrohradapter inkl. Gewinde nach Kundenwunsch
Ready machined draw tube adapter incl. thread according to customer's requirement

Art.-Nr. / Order no.

Beispiel / Ordering example = 29-ZRA-M74X2,0

▶ 29-ZRA-



Hydraulikzylinder mit Durchgang für hohe Drehzahlen

Hydraulic high speed cylinders with trough-hole

AUTO
Strong

Typ M
Type M



- kompakte und leichte Bauweise
- große Bohrung
- geeignet für hohe Drehzahlen
- *small sized and light-weight design*
- *large bore*
- *suitable for high speeds*

Typ / Type	Kolbendurchmesser / Piston dia mm	Kolbenfläche Druckseite / Piston area Pressure side cm ²	Kolbenfläche Zugseite / Piston area Pull side cm ²	Kolbenhub / Piston stroke mm	Max. Zugrohrkraft (öffnen) / Max. draw bar pull-push side kgf	Max. Zugrohrkraft (schließen) / Max. draw bar pull-pull side kgf	Max. Betriebsdruck / Max. operating pressure kgf / cm ²	Max. Drehzahl / Max. speed	Trägheitsmoment / Moment of inertia kg / m ²	kg	Gesamtundichtheit / Total leakage L / min	Art.-Nr. / Order no.
M0928	90	53,2	48,3	10	19,9 (2029)	18 (1835)	40,8	8000	0,006	5,5	3,0	29-M0928
M1036	105	71	68,5	15	24,8 (2529)	24 (2447)	40,8	8000	0,011	8,6	3,0	29-M1036
M1236	125	100	89	15	38 (3875)	33 (3365)	40,8	7000	0,019	13	3,0	29-M1236
M1246	125	100	89	15	38 (3875)	33 (3365)	40,8	7000	0,019	12	3,0	29-M1246
M1546	155	161	155	22	60 (6118)	56 (5710)	40,8	6200	0,052	18	3,9	29-M1546
M1552	155	161	150	22	60 (6118)	56 (5710)	40,8	6200	0,052	16,8	3,9	29-M1552
M1868	180	198	197	25	74 (7546)	73,5 (7495)	40,8	4700	0,098	28	4,2	29-M1868
M1870	180	198	183	25	74 (7546)	69 (7036)	40,8	4700	0,095	26,5	4,2	29-M1870
M1875	180	198	183	25	74 (7546)	69 (7036)	40,8	4700	0,095	26	4,2	29-M1875
M1878	180	198	183	25	74 (7546)	69 (7036)	40,8	4700	0,095	25,5	4,2	29-M1878
M2085	205	252	234	30	94 (9584)	88 (8973)	40,8	3800	0,15	37,5	4,5	29-M2085
M2091	205	252	234	30	94 (9584)	88 (8973)	40,8	3800	0,15	37	4,5	29-M2091
M2511	250	348	336	23	124 (12644)	120 (12236)	40,8	2800	0,45	57	7,0	29-M2511

Inkl. Kühlmittelsammler
Incl. coolant collector

Abmessungen siehe nächste Seite
Dimensions see next page

Dichtungssatz für Hydraulikzylinder

Seal kit for hydraulic cylinder



Für Typ / For type	Art.-Nr. / Order no.
M0928	29-M0928DS
M1036	29-M1036DS
M1236	29-M1236DS
M1246	29-M1246DS
M1546	29-M1546DS
M1552	29-M1552DS
M1868	29-M1868DS
M1870	29-M1870DS
M1875	29-M1875DS
M1878	29-M1878DS
M2085	29-M2085DS
M2091	29-M2091DS
M2511	29-M2511DS

Hydraulikzylinder mit Durchgang für hohe Drehzahlen Hydraulic high speed cylinders with trough-hole

Typ M, Abmessungen Type M, Dimensions

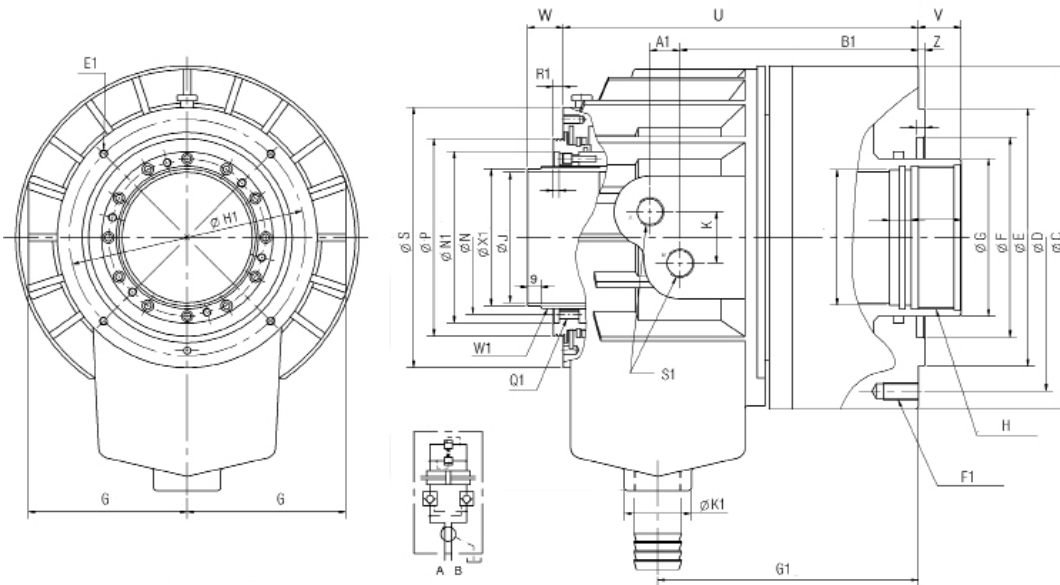

Typ / Type	C1 mm	E1 mm	F1 mm	G1 mm	H1 mm	J1 mm	K1 mm	L1 mm	M1 mm	N1 mm	O1 mm	P1 mm	Q1 mm	R1 mm	S1 mm	T1 mm	U1 mm	W1 mm	X1 mm	B mm	C mm
M0928	25	M6x1,0	M8x1,25	110	76	58	44	15	34	53	14	4	M4x0,7	5	PT1/4"	5	116	M34x1,5	32	85	120
M1036	25	M5x0,8	M10x1,5	126	88	68	53	15	38	64	14	4	M5x0,8	4	PT3/8"	6	136	M44x1,5	42	101	136
M1236	25	M6x1,0	M10x1,5	135	98	76	47	15	38	76	14	4	M5x0,8	6	PT1/2"	6	169	M52x1,5	50	99	154,5
M1246	30	M6x1,0	M10x1,5	135	98	76	47	15	50	76	14	4	M5x0,8	6	PT1/2"	6	169	M52x1,5	50	99	154,5
M1546	30	M6x1,0	M10x1,5	145	110	86	47	15	50	85	14	4	M6x1,0	7	PT1/2"	6	187,5	M58x1,5	56	103	190
M1552	30	M6x1,0	M10x1,5	145	110	86	47	15	55	85	14	4	M6x1,0	7	PT1/2"	6	187,5	M58x1,5	56	103	190
M1868	35	M6x1,0	M10x1,5	166	155	101	47	15	70	108	16	4	M6x1,0	7,5	PT1/2"	6	220	M84x2	81	126	215
M1870	35	M6x1,0	M10x1,5	166	155	101	47	15	75	108	16	4	M6x1,0	7,5	PT1/2"	6	220	M84x2	81	126	215
M1875	35	M6x1,0	M10x1,5	166	155	101	47	15	80	108	16	4	M6x1,0	7,5	PT1/2"	6	220	M84x2	81	126	215
M1878	35	M6x1,0	M10x1,5	166	155	101	47	20	82	108	16	4	M6x1,0	7,5	PT1/2"	6	220	M84x2	81	126	215
M2085	35	M6x1,0	M12x1,75	182	165	110	47	20	89	120	16	4	M6x1,0	7	PT1/2"	6	267	M99x2	96	141	240
M2091	35	M6x1,0	M12x1,75	182	165	110	47	15	95	120	16	4	M6x1,0	7	PT1/2"	6	267	M99x2	96	141	240
M2511	45	M6x1,0	M16x2,0	197	206	129	55	20	123	160	18	5	M6x1,0	7	PT1/2"	6	294	-	134,6	186	310

Typ / Type	D mm	E mm	F mm	G mm	H mm	J mm	K mm	L mm	N mm	P mm	Q mm	S mm	T mm	U max mm	V min mm	V max mm	W min mm	W mm	x mm	z mm	A1 mm	B1 mm
M0928	100	80	65	44	M38x1,5	28	25	54	44	59	65	90	105	156	9	-1	35	25	3	5	9	108
M1036	115	100	65	48	M42x1,5	36	32	62	54	73	80	104	115	179,5	10	-5	39	24	2,5	5	11	120,5
M1236	130	100	80	65	M42x1,5	36	36	67	64	85	90	118	114	184	10	-5	40	25	4	5	11	126,5
M1246	130	100	80	65	M55x2	46	36	67	64	85	90	118	114	184	10	-5	40	25	4	5	11	126,5
M1546	170	130	85	65	M55x2	46	36	75	73	96	102	137	130	196	17	-5	47	25	4	5	11	136
M1552	170	130	85	70	M60x2	52	36	75	73	96	102	137	130	196	17	-5	47	25	4	5	11	136
M1868	190	160	120	85	M75x2	68	36	84	98	121	131	166	160	230	20	-5	50	25	4	5	17,5	152,5
M1870	190	160	120	95	M78x2	70	36	84	98	121	131	166	160	230	20	-5	50	25	4	5	17,5	152,5
M1875	190	160	120	95	M85x2	75	36	84	98	121	131	166	160	230	20	-5	50	25	4	5	17,5	152,5
M1878	190	160	120	95	M87x2	78	36	84	98	121	131	166	160	230	20	-5	50	25	4	5	17,5	152,5
M2085	215	180	140	110	M93x2	85	36	93	108	138	148	182	185	253	25	-5	55	25	3	5	21	166,5
M2091	215	180	140	110	M100x2	91	36	93	108	138	148	182	185	253	25	-5	55	25	3	5	21	166,5
M2511	275	230	166	140	M130x2	117,5	36	89	148	178	-	232	215	296	18	-5	38	15	3	6	27	184,5



Einzelne Backen für Kraftspannfutter Single jaws for hydraulic power chucks

Strong AUTO

Weiche Aufsatzbacken, Stück Soft top jaws, piece

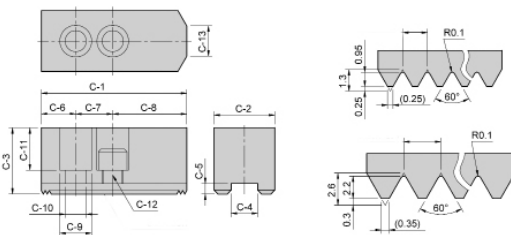

Typ / Type	C-1 mm	C-2 mm	C-3 mm	C-4 mm	C-5 mm	C-6 mm	C-7 mm	C-8 mm	C-9 mm	C-10 mm	C-11 mm	C-12 mm	C-13 mm	Verzahnung / Serration	kg	Art.-Nr. / Order no.
HC04	53	23	23	10	5	9	14	30	13,5	9	14	M8	3	1,5x60°	0,2	● 29-HC-04
HC05	62	25	30	10	5	9	14	39	13,5	9	21	M8	5	1,5x60°	0,3	● 29-HC-05
HC06	73	31	36	12	5	15	20	38	17	11	23	M10	14	1,5x60°	0,5	● 29-HC-06
HC08	95	35	37	14	5	24	25	46	19	13	22	M12	16	1,5x60°	0,8	● 29-HC-08
HC10	110	40	42	16	5	30	30	50	19	13	27	M12	18	1,5x60°	1,3	● 29-HC-10
HC12	130	50	50	21	5	39	30	61	25	17	30	M16	23	1,5x60°	2,2	● 29-HC-12
HC12-1	130	50	50	18	5	39	30	61	23	15	30	M14	23	1,5x60°	2,2	● 29-HC-12-1
HC15	165	62	62	22	8	37	43	85	32	21	38	M20	-	1,5x60°	4,2	● 29-HC-15
HC15-1	165	62	62	25,5	5	37	43	85	32	21	38	M20	-	1,5x60°	4,2	● 29-HC-15-1
HC24-1	180	65	70	25	9	40	60	80	32	21	45	M20	-	3,0x60°	5,3	● 29-HC-24-1
HC32-1	210	74	90	25	9	40	80	90	32	21	65	M20	-	3,0x60°	9,8	○ 29-HC-32-1

Preis pro Stück / Price per piece

Strong AUTO

Harte Aufsatzbacken, Stück Hard top jaws, piece

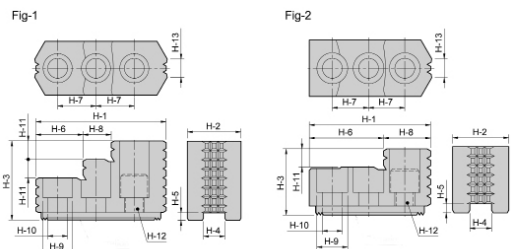

Typ / Type	H-1 mm	H-2 mm	H-3 mm	H-4 mm	H-5 mm	H-6 mm	H-7 mm	H-8 mm	H-9 mm	H-10 mm	H-11 mm	H-12 mm	H-13 mm	Abb. / Fig	Verz. / Serration	kg	Art.-Nr. / Order no.
HJ05	53	23	27,5	10	4	30,5	14	22,5	13,5	8,5	10	M8	6	2	1,5x60°	0,2	● 29-HJ-05
HJ06	67	31	36	12	5	39,5	20	27,5	17	11	10	M10	11	2	1,5x60°	0,3	● 29-HJ-06
HJ08	86	35	51	14	5	31	25	18	19	13	12	M12	12	1	1,5x60°	0,6	● 29-HJ-08
HJ10	99,5	40	54	16	5	43	30	17	19	13	13	M12	15	1	1,5x60°	1,0	● 29-HJ-10
HJ12	103	50	52	21	4	62,5	30	40,5	25	17	17	M16	30	2	1,5x60°	1,2	● 29-HJ-12
HJ12-1	103	50	52	18	5	62,5	30	40,5	22	15	17	M14	30	2	1,5x60°	1,2	● 29-HJ-12-1
HJ15	149	62	86	22	8	63	43	34	32	21	20	M20	40	1	1,5x60°	3,2	● 29-HJ-15
HJ15-1	149	62	86	25,5	5	63	43	34	32	21	20	M20	40	1	1,5x60°	3,2	● 29-HJ-15-1
HJ24-1	159,5	80	90	25	9	104,5	60	55	32	21	40	M20	55	2	3,0x60°	4,7	● 29-HJ-24-1

Preis pro Stück / Price per piece

ACHTUNG: Es handelt sich nicht um Backensätze, sondern um einzelne Backen
Für Zwei-Backen-Futter bitte 2 Stück bzw. für Drei-Backen-Futter 3 Stück usw. bestellen

ATTENTION: No sets are delivered, but single jaws
For two-jaw chucks please order 2 pieces, for three-jaw chucks 3 pieces etc.

**Backen kompatibel zu Kitagawa Kraftspannfuttern
Jaws compatible with Kitagawa power chucks**

Segmentbacken für Kraftspannfutter - Verzahnung 1,5 x 60° Pie jaws for power chucks - serration 1,5 x 60°

Weiche Segmentbacken für Kraftspannfutter, Satz Soft pie jaws for power chucks, set



- besonders für verformungsempfindliche Werkstücke geeignet
- Spannkraftübertragung auf große Spannfläche, da das Werkstück fast vollständig umschlossen wird
- können als Backenrohling für Sonderbacken genutzt werden
- suitable for thin-walled work pieces
- large clamping nearly the entire circumference of the work piece
- can be used as blanks for special jaws

Stahl / Steel

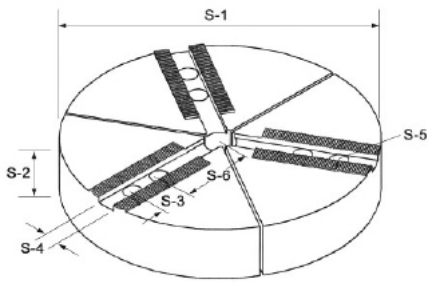

Für Futter-Typ / For chuck type	S-1 mm	S-2 mm	S-3 mm	S-4 mm	S-5 mm	S-6 mm	Durchg. / Thru hole mm	Verzahnung / Serration mm	Art.-Nr. / Order no.
206	169	40	20	12	M10	49,5	25	1,5x60°	● 29-SAB-06
208	200	40	25	14	M12	51	25	1,5x60°	● 29-SAB-08
208	200	50	25	14	M12	51	25	1,5x60°	○ 29-SAB-08-1
210	250	50	30	16	M12	65	25	1,5x60°	○ 29-SAB-10
212	300	50	30	21	M16	81	25	1,5x60°	○ 29-SAB-12

Preis pro Satz / Price per set

Nutensteine T-Nuts



Nutenstein für Kraftspannfutter, Stück T-nut for power chucks, piece



Fig. 1

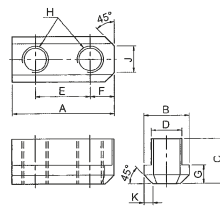

Fig. 2

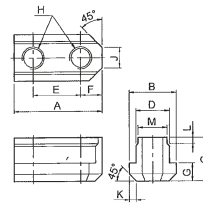
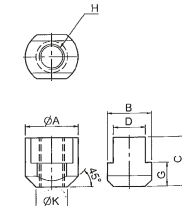

Fig. 3



Typ / Type	A mm	B mm	C mm	D mm	E mm	F mm	G mm	H mm	J mm	K mm	L mm	M mm	Abb. / Fig.	Passend zu Futter / Matching chuck	Art.-Nr. / Order no.
N0205-OH	26	14,5	15	10	14	6	5,5	M8	5	2	-	-	1	N-204, N-205	● 29-N0205-OH
N0206-OH	36	17,5	18,5	12	20	8,2	7,5	M10	8	2,5	-	-	1	N-206, NB-306	● 29-N0206-OH
N0208-OH	46,5	20,5	20,5	14	25	10,5	8,5	M12	12	4	-	-	1	N-208, NB-208	● 29-N0208-OH
N0210-OH	51	22,5	21,5	16	30	11	8,5	M12	11	3	-	-	1	N-210, NB-210	● 29-N0210-OH
N0212-OH	55,5	29,5	27,8	21	30	12	11,5	M16	13	4,5	-	-	1	N-212, NB-212	● 29-N0212-OH
N0215-OH	80	33,5	45,5	24	43	17	16,5	M20	11	5	8	22	2	N-215, N-218	● 29-N0215-OH
V0206-OH	36,5	17,5	22,5	12	20	7,5	7,5	M10	6	3	-	-	1	V-206, NHT-208	● 29-V0206-OH
V0208-OH	48	20,5	25,5	14	25	11	9,5	M12	8	4	-	-	1	V-208	● 29-V0208-OH
V0210-OH	55	22,5	25,5	16	30	11	9,5	M12	8	4	-	-	1	V-210	● 29-V0210-OH
V0212-OH	55,5	26,5	33,5	18	30	11,5	13,5	M14	12	5	-	-	1	V-212	● 29-V0212-OH
V0215-OH	42	35	39,2	25,5	-	-	19	M20	-	25	-	-	3	V-215, V-218	● 29-V0215-OH
V0215-OH1	42	35	41,2	26	-	-	19	M20	-	25	-	-	3	V-215P3,0	● 29-V0215-1-OH
V0224-OH	46	37,5	45	25	-	-	19	M20	-	26,5	-	-	3	N-220, N-224, V-221, V-224, V-232	● 29-V0224-OH

Lieferung erfolgt ohne Schrauben / Screws not included
Preis pro Stück / Price per piece

Lagerstandard / in stock
innerhalb weniger Tage / within a few days
auf Anfrage / on request
auslaufende Größe / as stock lasts

Ausdrehvorrichtungen für Kraftspannfutter

Jaw turning fixtures for power chucks

1

1.10

Ausdrehvorrichtungen für Kraftspannfutter

Jaw turning fixtures for power chucks

- schnelle und flexible Handhabung

- ease of handling

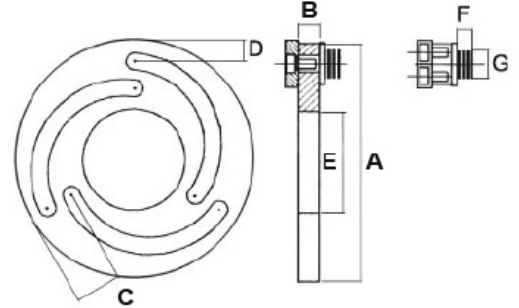

Für Futter-Typ / For chuck type	B mm	A mm	E mm	D mm	C mm	F mm	G mm	kg	Art.-Nr. / Order no.
205	12	140	60	12	28	9	13	2	● 29-ADKF-05
206	12	168	80	12	32	9	16,5	2	● 29-ADKF-06
208	12	218	115	15	36	9	18,5	3	● 29-ADKF-08
210	12	258	150	17	40	9	18,5	4	● 29-ADKF-10
212	15	316	188	21	50	9	22,5	6	● 29-ADKF-12
215	20	380	230	23	52	16	31	11	● 29-ADKF-15

Spannzangenfutter Collet chucks

Strong AUTO



Kraftspannzangenfutter CR Collet chucks CR power operated

- kompakte Bauweise
- hohe Rundlaufgenauigkeit
- compact design
- high concentricity

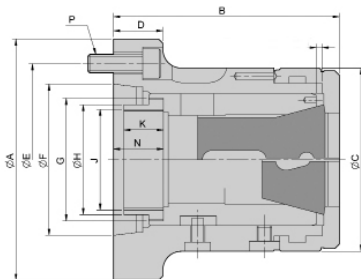

Futter / Chuck	Spannzange / Collet	○ max.	⬡ max.	□ max.
CR26	161E	26	22	18
CR30	163E	30	26	21
CR42	173E	42	36	30
CR60	185E	60	52	42
CR80	193E	80	69	56

Typ / Type	A mm	Aufnahme / Mounting	Max. Stangendurchmesser / Bar capacity mm	Spannhub / Sleeve stroke mm	Max. Betätigungskraft / Max. operating force (kN)	Max. Spannkraft / Max. gripping force (kN)	Max. Drehzahl / Max. speed (Upm)	kg	Art.-Nr. / Order no.
CR26A4	112	A2-4	26	5	20	44	7000	4,5	29-CR-26A4
CR30A4	112	A2-4	30	5	20	44	7000	4,1	29-CR-30A4
CR42	155	Zyl Ø140	42	7	25	55	6000	6,2	29-CR-42
CR42A5	135	A2-5	42	7	25	55	6000	6,2	29-CR-42A5
CR42A6	170	A2-6	42	7	25	55	6000	11,5	29-CR-42A6
CR60	185	Zyl Ø170	60	7	30	65	5000	13	29-CR-60
CR60A6	170	A2-6	60	7	30	65	5000	13	29-CR-60A6
CR80A8	220	A2-8	80	7	35	73	4000	21	29-CR-80A8

Typ / Type	B mm	C mm	D mm	E mm	F mm	G mm	H mm	J max.	K mm	N mm	P mm	T mm
CR26A4	103,5	85	30	82,55	63,513	M50x1,5	45	M40x1,5	15	21,7	3-M10	2,3
CR30A4	103,5	85	30	82,55	63,513	M50x1,5	45	M40x1,5	15	21,7	3-M10	2,3
CR42	114	100	23	104,78	140	M66x1,5	66	M55x2,0	25	-	3-M10	3,1
CR42A5	124	100	27	104,78	82,563	M66x1,5	60	M55x2,0	25	27,4	4-M10	3,1
CR42A6	124	100	32	133,35	106,375	M66x1,5	66	M60x2,0	22	27,4	4-M12	3,1
CR60	139	130	30	133,35	170	M90x1,5	80	M74x2,0	30	-	6-M12	3,1
CR60A6	145	130	27	133,35	106,375	M90x1,5	80	M74x2,0	30	29,9	4-M12	3,1
CR80A8	170	156	35	171,45	139,719	M114x2,0	99	M90x2,0	27,5	34,9	6-M16	6,1

Pneumatische Spannzangenfutter für Druckspannzangen Pneumatic collet chucks for dead length collets

- pneumatische Spannung
- hochpräzise Werkstückzentrierung
- horizontal und vertikal einsetzbar
- pneumatic clamping
- precise centering of work piece
- for horizontal and vertical application

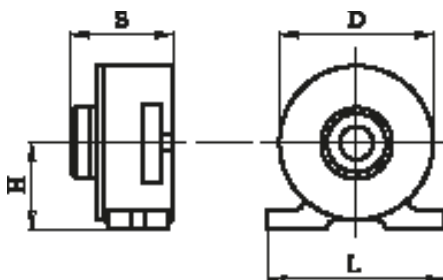

Für SZ / For collet	D mm	H mm	L mm	S mm	Spannkraft / Clamping force bei / per 6 bar	Spannkraft / Clamping force bei / per 8 bar	Spannkraft / Clamping force bei / per 10 bar	Art.-Nr. / Order no.
161E (2-26)	152	77	170	97	5 kN	7 kN	9 kN	14-PSF-161E
173E (3-42)	165	85	180	117	6 kN	8 kN	10 kN	14-PSF-173E

Spannzangenfutter Collet chucks

1

1.11

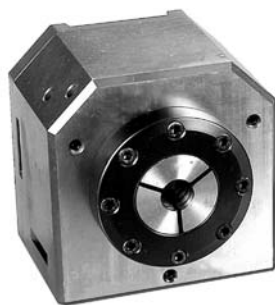

Pneumatische Spannzangenfutter, Module Pneumatic chucking devices, modules

- Pneumatisch betätigte Spannzangenfutter
- für den Einsatz mehrerer Futter nebeneinander geeignet
- horizontal und vertikal einsetzbar
- pneumatically operated collet chuck
- suitable for side by side application
- for horizontal and vertical use

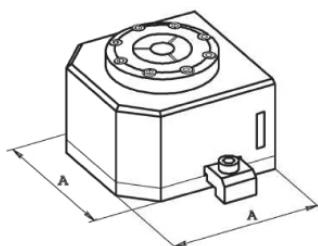
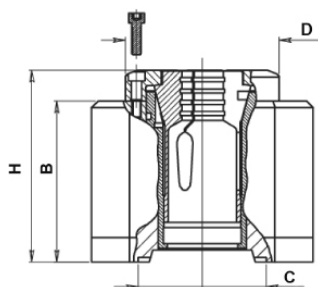

Inkl. zwei Spannpratzen
Incl. two brackets

Für SZ / For collet	B mm	H mm	C mm	D mm	Art.-Nr. / Order no.
120E (2-12)	70	82	42	58	▶ 14-PSM-120E
140E (2-18)	70	82	42	58	▶ 14-PSM-140E
161E (2-26)	100	119	80	96	▶ 14-PSM-161E
173E (3-42)	100	119	80	96	▶ 14-PSM-173E
W20 (1-20)	70	82	42	-	▶ 14-PSM-W20

Spannzangenfutter für Druckspannzangen Collet chucks for dead-length collets

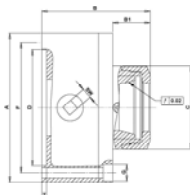

Technische Merkmale:

- Handbetätigung mit Schlüssel am Futterkörper
- Standardaufnahme DIN 6350
- einsetzbar auf Dreh- und Schleifmaschinen

Technical features:

- manually operated by wrench
- standard mounting DIN 6350
- suitable for turning and grinding

Für SZ / For collet	A mm	B mm	B1 mm	C mm	D (H6) mm	F mm	G Ø	T mm	SW mm	RPM _{MAX} min ⁻¹	Art.-Nr. / Order no.
161E (2-26)	160	115	40	90	125	140	3x10,5	5	11	4500	▶ 79-SZF-161E
163E (2-30)	160	115	40	90	125	140	3x10,5	5	11	4500	▶ 79-SZF-163E
164E (2-32)	160	115	40	90	125	140	3x10,5	5	11	4500	▶ 79-SZF-164E
173E (3-42)	160	115	40	90	125	140	3x10,5	5	11	4500	▶ 79-SZF-173E
185E (4-60)	200	125	78	152	160	176	3x10,5	5	11	4000	▶ 79-SZF-185E

Inkl. Betätigungsschlüssel, Hakenschlüssel und Befestigungsschrauben
Incl. wrench, hook spanner and fixing screws



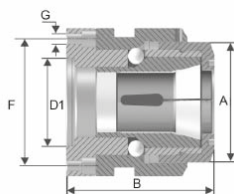

Handhebelfutter, zylindrische Aufnahme Lever-operated collet chuck, centre mount

- Schnellspannfutter für Spannzangen Typ 173E
- Betätigung über Handhebel
- collet chuck for collets type 173E
- manually operated by a lever

Für SZ / For collet	B mm	A mm	D1 mm	F mm	G mm	RPM _{MAX} min-1	Art.-Nr. / Order no.
173E (3-42)	130	96	70	101	5 x 8,5	2000	ZE-HHF-173E

Passende Spannzangen auf Seite 199
Suitable collets see page 199

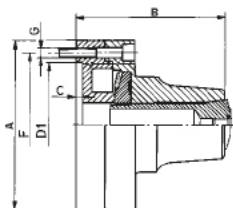

5C-Spannzangenfutter, mit zylindrischer Aufnahme 5C-collet chuck, centre mount

C mm	A (Ø) mm	D1 mm	F mm	G mm	B mm	RPM _{MAX} min-1	kg	Art.-Nr. / Order no.
4	126	95	108	3 x M8 x 45	107,4	6000	4,5	ZE-SF5C-125

5C-Spannzangenfutter, mit Adapter 5C-collet chuck, with adapter

Aufnahme / mount	Kurzkegel / Taper	Art.-Nr. / Order no.
DIN 55027	4"	ZE-SF5C/7-125/4
DIN 55027	5"	ZE-SF5C/7-125/5
DIN 55029	4"	ZE-SF5C/9-125/4
DIN 55029	5"	ZE-SF5C/9-125/5

Inkl. Spannschlüssel und Befestigungsschrauben
Incl. wrench and fixing screws

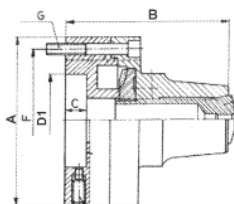

5C-Spannzangenfutter, mit zylindrischer Aufnahme, mit radialer Feineinstellung 5C-collet chuck, centre mount, with radial fine adjustment

C mm	A (Ø) mm	D1 mm	F mm	G mm	B mm	RPM _{MAX} min-1	kg	Art.-Nr. / Order no.
15	126	55	108	3 x M8 x 70	127	6000	6	ZE-SF5C-125FE

Inkl. Spannschlüssel und Befestigungsschrauben
Incl. wrench and fixing screws

Mit allen gängigen Spindelaufnahmen lieferbar. Passende Spannzangen auf Seite 198
Available for all spindle tapers. Suitable collets see page 198

Spannzangenfutter Collet chucks

1

1.11

Spannzangenfutter / Collet chucks

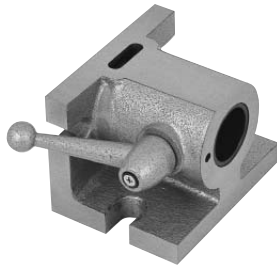

Spannzangenhalter für 5C-Spannzangen 5C-collet fixture

- Handbetätigt
- horizontal und vertikal einsetzbar
- Schnellspannhebel
- *manually operated*
- *for horizontal and vertical use*
- *quick clamping with lever*

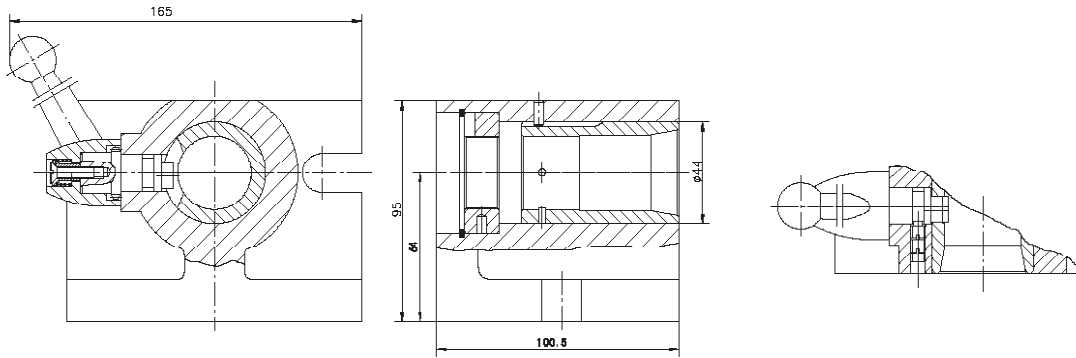

kg

Art.-Nr. /
Order no.

5

14-SHV-5C



Spannzangenhalter-Set 2-teilig, für 5C-Spannzangen 5C-collet block set, 2-piece

- zum Spannen von Werkstücken ohne separates Spannzangenfutter, z.B. in Drehfutterm oder Schraubstöcken
- inkl. 4-Kant- und 6-Kant-Hülse
- Spitzenhöhe: 22,2 mm
- *for clamping of workpieces without separate collet chuck*
- *incl. square and hexagonal sleeve*
- *centre height: 22,2 mm*

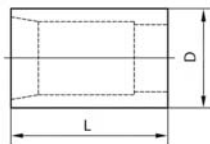

L
mm

D
mm

kg

Art.-Nr. /
Order no.

70

44,45

1,5

14-SHDF-5C

Dreh- und schwenkbares Spannzangenfutter
Universal angle collet chuck

- für Spannzangen ER40 (2-30)
 - mit Skalenring 360°
 - Toleranz ± 0,01 mm / 100 mm
 - 45° schwenkbar
 - Nonius
- for collets ER40 (2-30)
 - 360° scale ring
 - tolerance ± 0.01 mm / 100 mm
 - 45° vertical tilting
 - Vernier

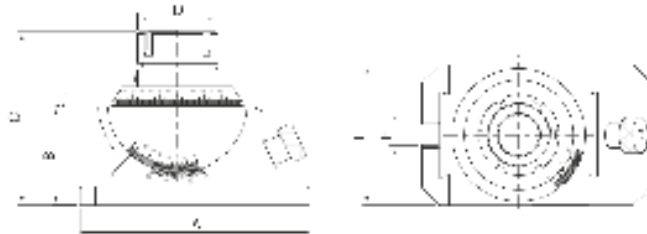

A mm	B mm	C mm	D mm	E mm	F mm	Art.-Nr. / Order no.
180	77	136	63	110	16	ZE-SZS-ER40

Passende Spannzangen Seite 191
Suitable collets see page 191

Spannzangenvorrichtungen
Collet fixtures



Spannzangenvorrichtungen
Collet fixtures

- mit zylindrischer Aufnahme
 - geeignet als stationäre Spannvorrichtung oder zur Aufnahme im Drehfutter
- cylindrical mounting
 - suitable as stationary clamping device or for use in lathe chucks

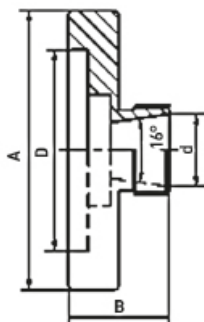

Für SZ / For collet	A mm	D mm	B mm	Art.-Nr. / Order no.
ER 16	45	22	25	ZE-SPV-ER16-045
ER 25	100	72	36	ZE-SPV-ER25-100
ER 32	80	55	42	ZE-SPV-ER32-080
ER 32	125	95	42	ZE-SPV-ER32-125

Passende Spannzangen Seite 191
Suitable collets see page 191

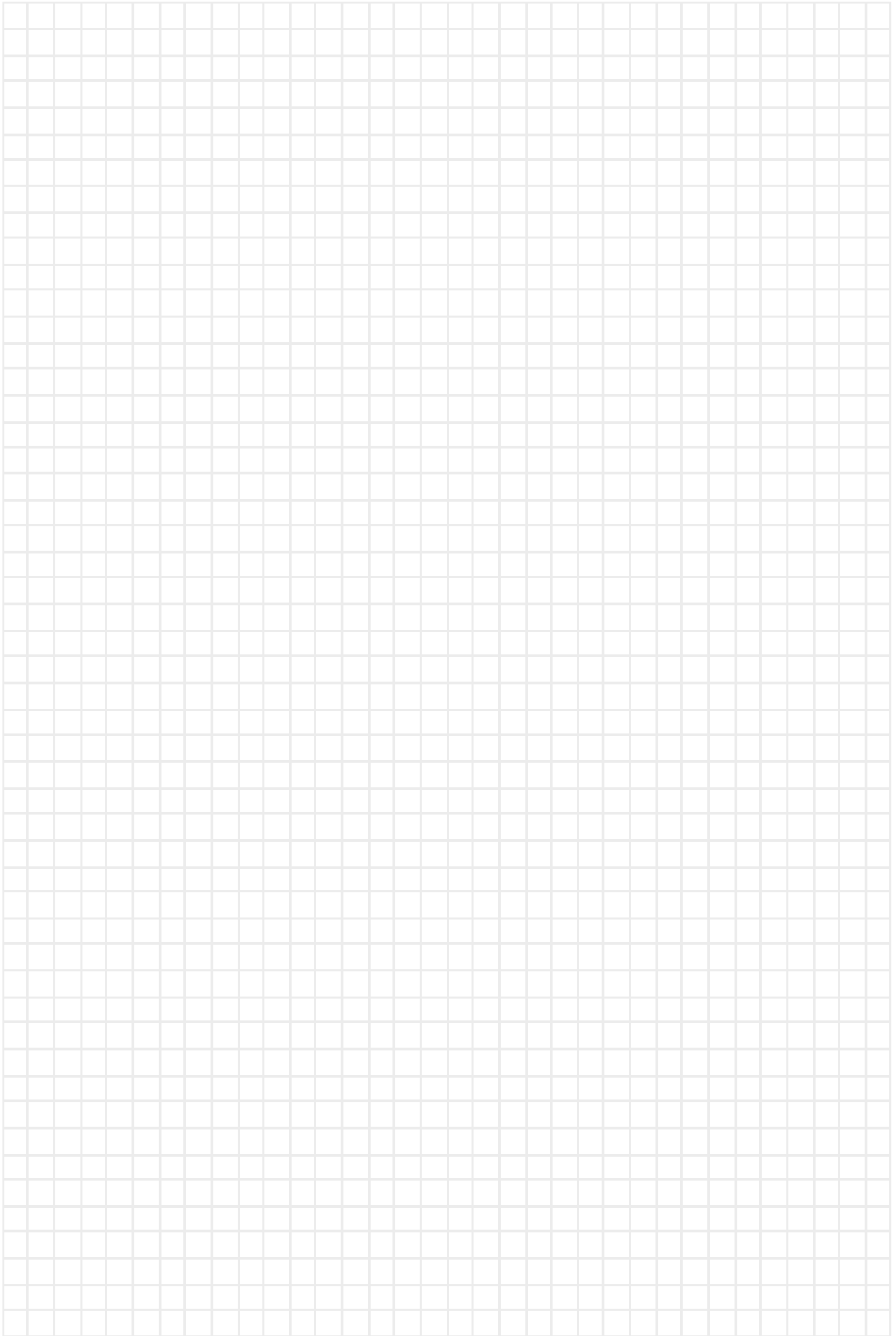

- Lagerstandard / *in stock*
- ▶ innerhalb weniger Tage / *within a few days*
- auf Anfrage / *on request*
- * auslaufende Größe / *as stock lasts*



Aufspannvorrichtungen, Prismenblöcke und Winkelprismen, Schraubböcke, Magnetspannplatten, Klauenkästen, Kreuz- und Schiebetische, Aufspannwinkel und Aufspannwürfel

Clamping fixtures, V-blocks and angle prisms, levelling screws, magnetic plates, box jaws, cross and slide tables, angle plates and clamping cubes

2

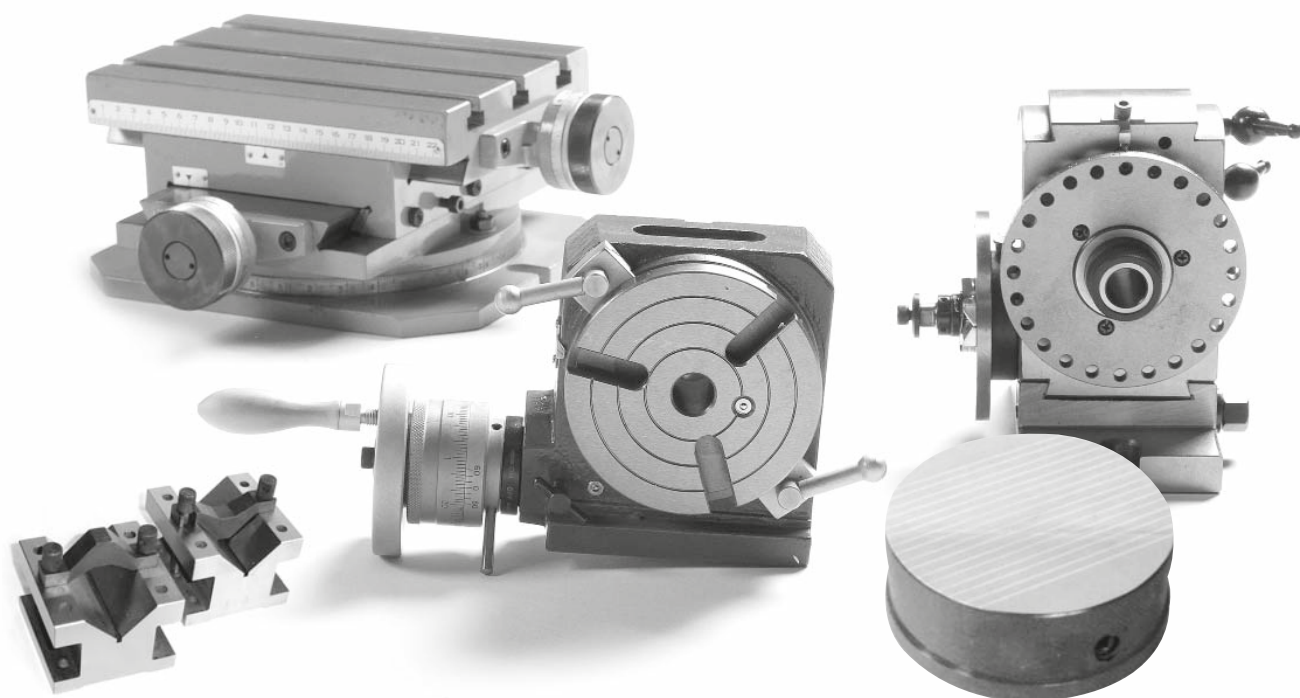

■ Inhalt:

2.1 | Aufspannvorrichtungen

- | Rundtische
- | Teilapparate
- | Reitstöcke
- | Zubehör für Teilapparate und Rundtische
- | Rundtische und Teilapparate inkl. Drehfutter
- | Schwenkbare Rundtische, Spanntische
- | Stationäre Drehfutter
- | Drehfutter auf Drehplatte

2.2 | Prismenblöcke und Winkelprismen

2.3 | Schraubböcke

2.4 | Magnetspannplatten

2.5 | Klauenkästen

2.6 | Kreuz- und Schiebetische

2.7 | Aufspannwinkel und Aufspannwürfel

■ Content:

2.1 | Clamping fixtures

- | Rotary tables
- | Indexing fixtures
- | Tailstocks
- | Accessories for indexing fixtures and rotary tables
- | Rotary tables and indexing fixtures incl. lathe chucks
- | Rotary table, tiltable and swivel angle plates
- | Stationary lathe chucks
- | Lathe chucks on swivel plate

2.2 | V-Blocks and angle prisms

2.3 | Levelling screws

2.4 | Magnetic plates

2.5 | Box jaws

2.6 | Cross and slide tables

2.7 | Angle plates and clamping cubes

Rundtische und Teilapparate

Rotary tables and indexing fixtures

2
2.1

Aufspannvorrichtungen / Clamping fixtures

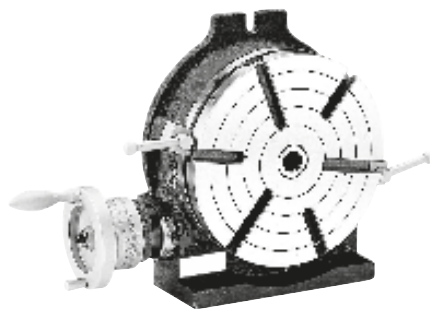

Präzisions-Rundtisch

Precision rotary table

- horizontal und vertikal einsetzbar
 - Übersetzung 90:1
 - 360° Skalierung, Skaleneinteilung 1', mit Nonius 10'', Vorschub 4° je Umdrehung
 - Parallelität 0,02 mm, Rechtwinkligkeit 0,02 mm, Rundlaufgenauigkeit 0,015 mm
- for horizontal and vertical applications
 - ratio 90:1
 - 360° graduation, 1' graduation, with vernier 10'', feed 4° per rotation
 - parallelism 0,02 mm, squareness 0,02 mm, runout 0,015 mm

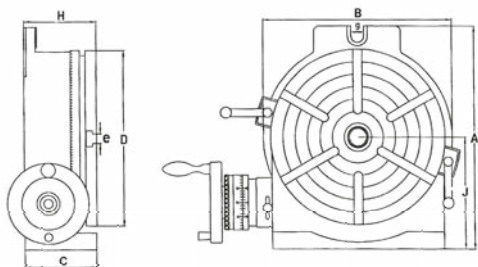

Max. Belastung /
Max. load cap.

Typ / Type	MK / MT	A mm	C mm	B mm	D mm	e mm	H mm	J mm	Nuten / Slots	Nut (g) / Slot (g) mm	Hor. kg	Vert. kg	kg	Art.-Nr. / Order no.
110	2	138	58	118	110	11	72	80	3	-	35	18	8	ZE-RT-110
150	2	205	78	163	150	11	80	102	3	17	40	20	13	ZE-RT-150
200	3	265	100	219	205	14	102	135	3	17	80	40	27	ZE-RT-200
250	3	321	106	276	254	14	109	163	6	17	90	50	38	ZE-RT-250
300	4	388	123	330	305	16	125	194	6	17	120	60	70	ZE-RT-300
350	4	445	123	389	353	16	125	225	6	17	130	70	91	ZE-RT-350
406	4	503	128	435	406	16	130	255	6	17	140	70	124	ZE-RT-406

Passende Flansche und Zubehör siehe Seite 77 und 78
Suitable adaptor plates and accessories see page 77 and 78



Direkt-Teilapparat

Simple indexing spacer

- horizontal und vertikal einsetzbar
 - schnell verstellbar, einfache Handhabung
 - inkl. Drehfutter und Rastplatten 2, 3, 4, 6, 8, 12, 24-fach einstellbar
- for horizontal and vertical applications
 - ease of handling
 - incl. lathe chuck and masking plates in 2, 3, 4, 6, 8, 12, 24 sections adjustable

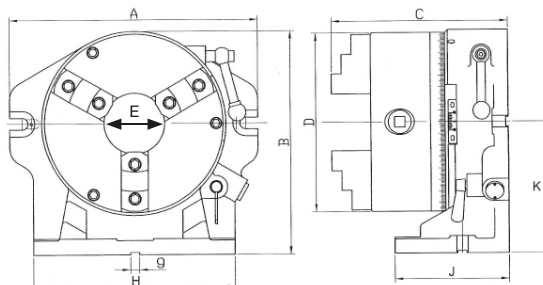
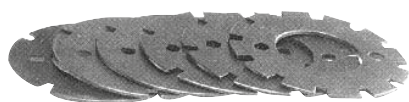

Typ / Type	Durchlass Teilapparat / Trough hole spacer mm
165	44
200	63
310	106

Typ / Type	Teilung / division	A mm	B mm	C mm	D mm	H mm	J mm	K mm	Nut (g) / Slot (g) mm	Spannbereich / clamp. range	E mm	kg	Art.-Nr. / Order no.
165	2-24	253	225	179	160	187	115	130	16	3-160	44	30	ZE-TA-165
200	2-24	318	274	209	200	230	157	157	16	4-200	58	52	ZE-TA-200
310	2-48	432	388	315	315	350	228	228	16	10-315	105	163	ZE-TA-310

Inkl. Dreiflanken-Drehfutter, Rastplatten
Incl. 3-jaw lathe chuck and masking plates



Teilapparate Indexing fixtures

Teilapparat mit Handrad Super indexing spacer with hand wheel

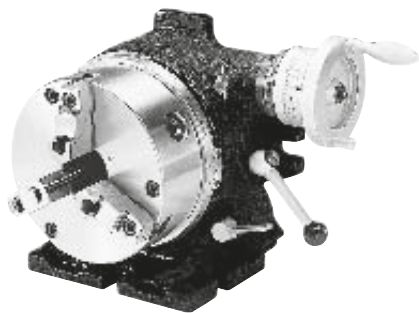

- horizontal und vertikal einsetzbar
 - Übersetzung 90:1, Skaleneinteilung 1' mit Nonius 10"
 - Teilung durch Indexrastung in 2, 3, 4, 6, 8, 12 und 24 Teile
 - inkl. Drehfutter, Aufspannscheibe, Rastplatten
- for horizontal and vertical applications
 - ratio 90:1, 1' graduation, with vernier 10"
 - indexing graduation in 2, 3, 4, 6, 8, 12 and 24 sections
 - incl. lathe chuck, face plate and masking plates

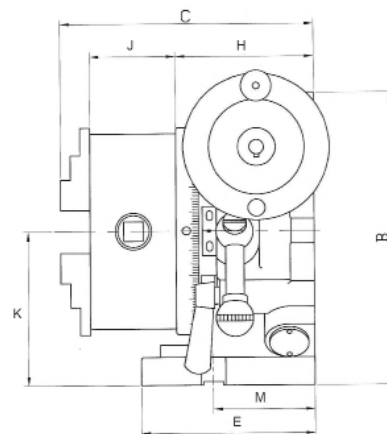
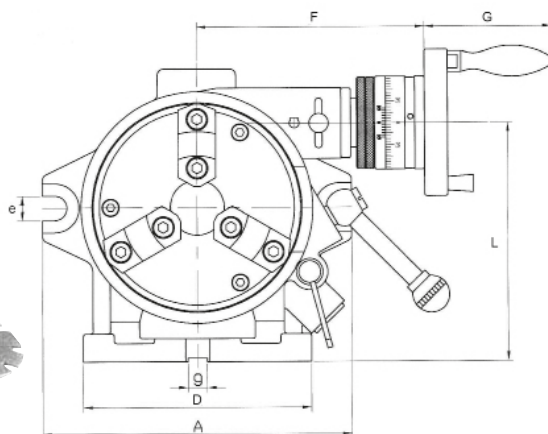
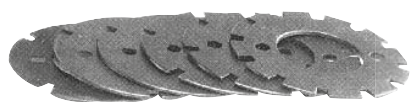
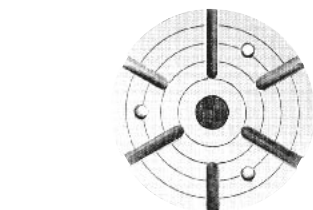

Typ / type	Teilung / division	Futter / chuck			Aufspannscheibe / face plate		A mm	D mm	B mm	C mm
		Ø	Spann- bereich / clamp. range	Bohrung-Ø / hole-Ø	Ø	Dicke / thickness				
165	2-24	160	4-156	44	203	50	250	220	235	221
200	2-24	210	4-180	58	254	58	310	225	285	243

Typ / Type	E mm	F mm	G mm	H mm	J mm	K mm	L mm	M mm	e mm	Nut (g) / Slot (g) mm	kg	Art.-Nr. / Order no.
165	150	184	82	112	66	123	186	80	18	16	45	ZE-TAK-165
200	160	201	82	125	75	155	232	90	18	16	79	ZE-TAK-200

Inkl. Dreibacken-Drehfutter, Aufspannscheibe, Rastplatten
Incl. 3-jaw lathe chuck, face plate and masking plates



Halb-Universal Teilapparat Semi-universal dividing head

- Teilung durch Indexrastung in 2, 3, 4, 6, 8, 12 und 24 Teile
- horizontal/vertikal schwenkbar von -10° bis +90°
- durch indirekte Teilung jede Teilung 2 bis 50 und viele Teilungen bis 380 möglich (Übersetzungsverhältnis 1:40)
- direct indexing in 2, 3, 4, 6, 8, 12 and 24 sections
- horizontally/vertically tiltable from -10° to +90°
- indirect indexing of all numbers from 2 to 50 and many numbers up to 380 (ratio 1:40)

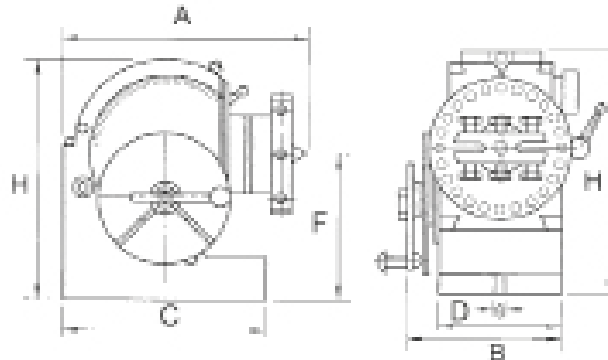
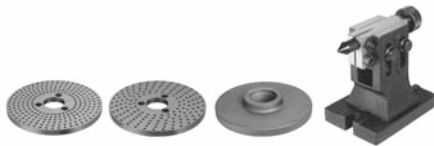

F mm	MK / MT	A mm	B mm	H mm	C mm	D mm	Nut (g) / Slot (g) mm	Spindel / Spindle Ø	Flansch / Adapter Ø	inkl. Reitstock / incl. tailstock	kg	Art.-Nr. / Order no.
100	2	196	133	173	160	91	16	16	100	RSV-108	22	ZE-HUT-1
126	3	253	163	220	207	114	16	20	130	RSV-145	36	ZE-HUT-2

Inkl. Reitstock, Flansch und 2 Teilscheiben / Incl. tailstock, adaptor plate and 2 dividing plates

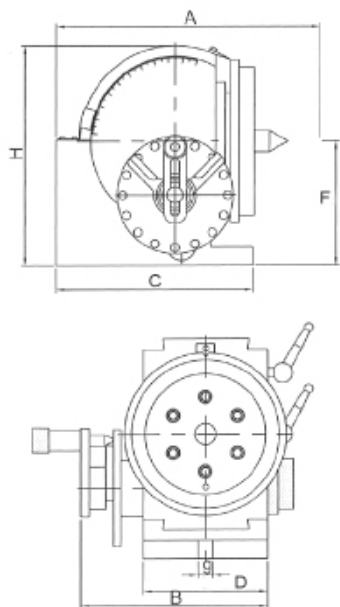

Universal Teilapparat Universal dividing head

- beliebige Winkel einstellbar durch direkte oder indirekte Teilung
- Teilung durch Indexrastung in 2, 3, 4, 6, 8, 12 und 24 Teile
- durch indirekte Teilung jede Teilung 2 bis 50 und viele Teilungen bis 380 möglich (Übersetzungsverhältnis 1:40)
- schnelle Umstellung auf Direktteilung
- Horizontal / vertikal schwenkbar von -10° bis +90°
- any angle possible by direct or indirect indexing
- direct indexing in 2, 3, 4, 6, 8, 12 and 24 sections
- indirect indexing of all numbers from 2 to 50 and many numbers up to 380 possible (ratio 1:40)
- easy conversion to direct indexing
- horizontally / vertically tiltable from -10° to +90°

F mm	MK / MT	A mm	B mm	H mm	C mm	D mm	Nut (g) / Slot (g) mm	Spindel / Spindle Ø	kg	Art.-Nr. / Order no.
134	4	285	202	237	213	134	16	25	36	ZE-VUT-2A

Inkl. Reitstock und 2 Teilscheiben / Incl. tailstock and 2 dividing plates



Zubehör für Teilapparate und Rundtische

Accessories for indexing fixtures and rotary tables

Teilscheiben für Rundtische

Dividing plates for rotary tables

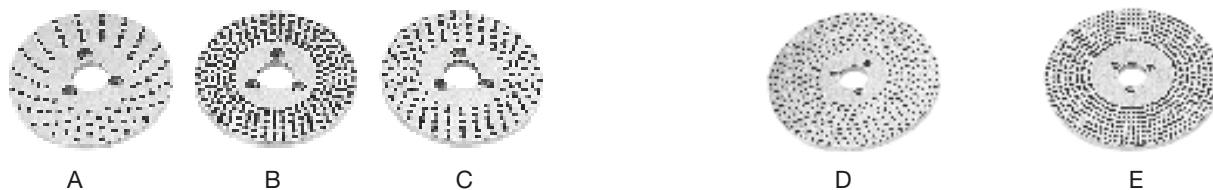

Typ / Type
Mögliche Teilungen / possible divisions

A	15, 16, 17, 18, 19, 20
B	21, 23, 27, 29, 31, 33
C	37, 39, 41, 43, 47, 49

Typ / Type
Mögliche Teilungen / possible divisions

D	26, 28, 30, 32, 34, 37, 38 39, 41, 43, 44, 46, 47, 49 51, 53, 57, 59
E	61, 63, 67, 69, 71, 73, 77 79, 81, 83, 87, 89, 91, 93 97, 99

Satz / Set	Passend zu / Suitable for	Typ / Type	Art.-Nr. / Order no.
1	ZE-RT-110 / -150	A, B, C	ZE-TS-1
2	ZE-RT-200	D, E	ZE-TS-2
3	ZE-RT-250 / -300 / -350 / -406	D, E	ZE-TS-3

Reitstöcke für Rundtische und Teilapparate

Tailstocks for rotary tables and dividing heads



- höhenverstellbar

- height adjustable

Passend zu / Suitable for	Höhe / height		Nut (g) / Slot (g) mm	kg	Art.-Nr. / Order no.
	max.	min.			
ZE-HUT-1, ZE-RT-110 / -150	108	80	16	4	ZE-RSV-108
ZE-HUT-2, ZE-TA-165, ZE-TAK-165, ZE-RT-200	150	115	16	6	ZE-RSV-145
ZE-TA-200, ZE-TAK-200, ZE-RT-250 / -300	205	130	16	8	ZE-RSV-200
ZE-RT-350 / -406, ZE-TA-310	260	182	16	12	ZE-RSV-260

Zubehör für Teilapparate und Rundtische

Accessories for indexing fixtures and rotary tables

2
2.1

Aufspannvorrichtungen / Clamping fixtures



Reitstöcke Tailstocks

- hochpräzise Ausführung
 - mit Pinole MK 3
 - ohne Höhenverstellung
- high precision type
 - with quill MT 3
 - without height adjustment

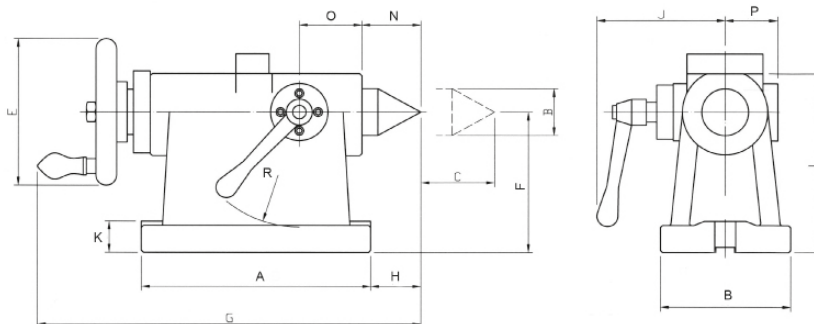

F	MK / MT	C	D	E	A	B	G	H	K	J	L	M	N	O	P	Q	R	Nut (g)/ Slot (g)	kg	Art.-Nr. / Order no.
135	3	55	Ø14	125	215	120	332	25	25	109	164	19	40	69	44	70	80	18	21	ZE-RSF-135
160	3	55	Ø18	140	230	130	356	30	30	129	193	19	45	70	52	80	95	18	23	ZE-RSF-160
210	3	55	Ø18	140	230	146	356	30	30	129	243	23	45	70	52	80	95	18	29,4	ZE-RSF-210

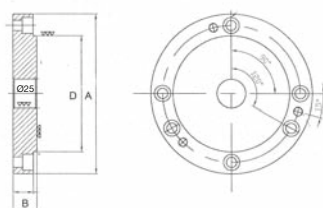

Flansche für Rundtische Adaptor plates for rotary tables

Passend zu / Suitable for	A	D	B	kg	Art.-Nr. / Order no.
ZE-RT-150 / -200	138	100	20	2	ZE-FLRT-0
ZE-RT-200 / -250	170	130	21	4	ZE-FLRT-1
ZE-RT-250 / -300 / -350	195	155	24	6	ZE-FLRT-2
ZE-RT-300 / -350 / -406	210	165	24	5	ZE-FLRT-3

Zentrierdorne mit Morsekegel für Rundtisch-Flansche Centering arbors with morse taper for rotary table adaptor plates



Passend zu / Suitable for	MK / MT	Art.-Nr. / Order no.
ZE-RT-150 / -200	2	ZE-ZD-MK2
ZE-RT-200 / -250	3	ZE-ZD-MK3
ZE-RT-300 / -350 / -406	4	ZE-ZD-MK4

Teilapparate und Rundtische inkl. Drehfutter Indexing fixtures and rotary tables incl. lathe chuck



Beispiel / example

Rundtisch inkl. Dreibacken-Drehfutter, geteilte Backen Rotary table incl. three-jaw lathe chuck, two-piece jaws

Typ / Type	Drehfutter-Ø / Chuck-Ø	Art.-Nr. / Order no.
RT150	130	▶ ZE-RT-150DF
RT200	160	▶ ZE-RT-200DF
RT250	190	▶ ZE-RT-250DF
RT300	250	▶ ZE-RT-300DF

**Auf Anfrage auch mit einteiligen Backen lieferbar /
With one-piece jaws available upon request**



Beispiel / example

Teilapparat inkl. Dreibacken-Drehfutter, einteilige Backen Indexing fixture incl. three-jaw lathe chuck, one-piece jaws

Typ / Type	Drehfutter-Ø / Chuck-Ø	Art.-Nr. / Order no.
VUT2A	200	▶ ZE-VUT-200KPL

Inkl. Reitstock und 2 Teilscheiben / Incl. tailstock and 2 dividing plates

Schwenkbarer Präzisions-Rundtisch

Precision rotary table, tiltable

Typ UT

Type UT

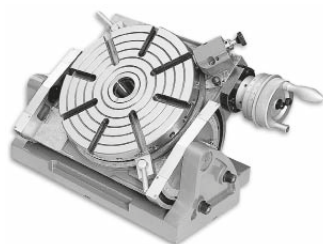

- stabile Bauweise
 - Spitzhöhe verstellbar von min. 113 mm bis max. 230 mm
 - Winkel verstellbar 90°
 - mit 10" Nonius
 - Skalenteilung 1'
- rugged construction
 - center height min. 113 mm up to max. 230 mm
 - tilting range 90°
 - with 10" vernier
 - graduation 1'

A	B	C	D	E	F	Übers. / Ratio	MK / MT	kg	Art.-Nr. / Order no.
305	172	366	192	340	460	90:1	5	97	13-UT300
Teilscheiben / Dividing plates									
A: 24, 25, 26, 28, 32, 37, 38, 41, 42, 43									
B: 46, 47, 49, 51, 53, 54, 57, 58, 59, 62, 66									
									13-UT300-TS

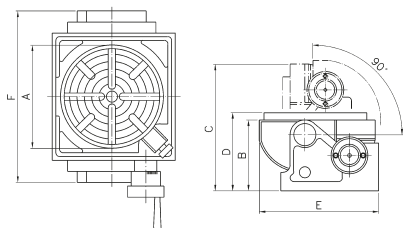

Passende Reitstöcke siehe Seiten 77 und 78
Suitable tailstocks see pages 77 and 78

Flansch passend zu Typ UT

Adaptor plate suitable for type UT

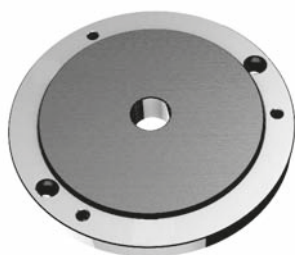

passend zu Typ / suitable for type	für Drehfutter Ø / for chuck Ø	Art.-Nr. / Order no.
UT 300	250	13-UT-300FL

Passendes Drehfutter siehe Seite 13, Typ ZE-6353-250
(muss von vorne durchbohrt werden)
Suitable chuck see page 13, type ZE-6353-250
(needs to be drilled from front)

Schwenkbare Spanntische, 90°

Heavy-duty tilting plates, 90°

- zum Aufspannen von verschiedenen Vorrichtungen, wie z.B. Schraubstöcken, Drehfuttern, etc.
- used for mounting of different devices, such as vices, lathe chucks, etc.

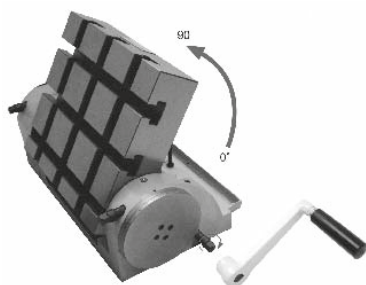

Belastbarkeit / loading capacity	Horizontal / horizontal kg	Vertikal / vertical kg
14-SSP-150	30	12
14-SSP-270	45	20
14-SSP-320	70	35

A	B	C	D	E	Positioniernut g / positioning slot g	G	H	F	J	L	K	M	N	P	Q	R	S	Nut (e) / Slot (e) mm	T	kg	Art.-Nr. / Order no.
180	285	113	156	150	16	20	115	44	16	50	44	28	50	50	30	145	140	10	251	18	14-SSP-150
255	399	150	270	258	16	22	155	72	20	70	72	55	80	80	45	207	192	12	291	60	14-SSP-270
300	449	169	320	298	16	26	169	92	25	75	92	60	98	100	48	232	217	16	305	83	14-SSP-320

Spanntische Swivel angle plates

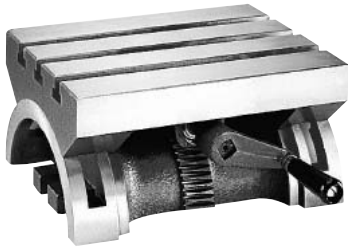

Schwenkbarer Spanntisch, Typ HWCK2 Swivel angle plate, type HWCK2

- in beide Richtungen schwenkbar
- $\pm 45^\circ$ verstellbar
- swivel-type
- adjustable $\pm 45^\circ$

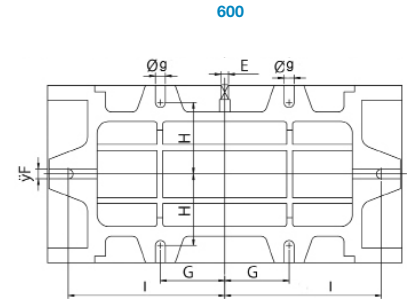
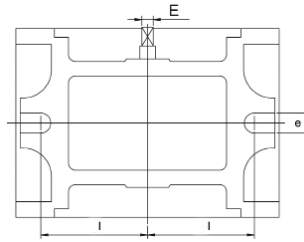
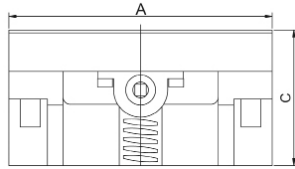
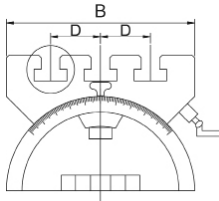
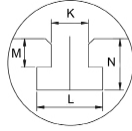

Größe / Size	A mm	B mm	C mm	D mm	E mm	e mm	g mm	I mm	G mm	H mm	J mm	K mm	L mm	M mm	N mm	kg	Art.-Nr. / Order no.
180x130	185	132	95	35	8	14	-	75	-	-	-	13	23	10	18	7,5	14-HWCK2-180
250x178	255	180	136	50	10	16	-	95	-	-	-	16	26	13,5	29	29	14-HWCK2-250
380x260	380	255	181	69	13	18	-	150	-	-	-	16	26	14	25	56	14-HWCK2-380
600x300	600	300	202	80	13	16	17	265	109	121	16	16	26	13	23	85	14-HWCK2-600

Dreh- und schwenkbarer Spanntisch Swivel and tiltable angle plate

- 360° drehbar, 30° schwenkbar
- schnelle, einfache Einstellung
- Präzisionsgeschliffene Grundplatte
- Belastbarkeit: 15 kg
- 360° rotatable, 30° tiltable
- fast and simple setting
- plate is precisely ground
- loading capacity: 15 kg

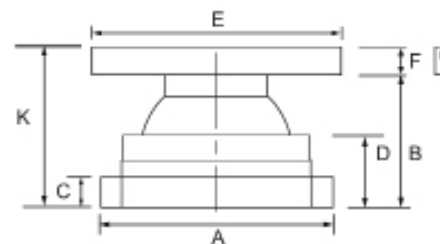
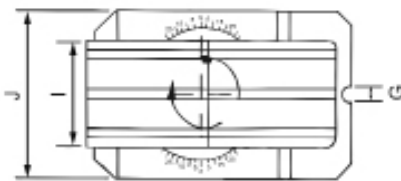

A mm	B mm	C mm	D mm	E mm	I mm	F mm	G mm	H mm	J mm	K mm	kg	Art.-Nr. / Order no.
190	120	20	72	200	100	34	17	12	140	153	15	ZE-MDS-200
190	120	20	72	250	126	34	17	12	140	153	17	ZE-MDS-250

Stationäre Drehfutter Stationary lathe chucks

Stationäre Dreibacken-Drehfutter, extraflach Stationary three-jaw lathe chucks, extra thin

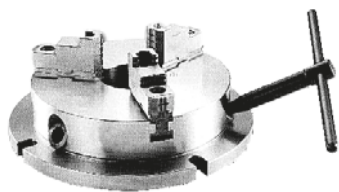

- Winkel zwischen Handgriff und Drehplatte beträgt 30°, dadurch bequeme Bedienung
- geringe Bauhöhe des Futters für mehr Arbeitsraum
- harte und weiche Aufsatzbacken können eingesetzt werden
- 30° angle between wrench and base for ease of handling
- extra thin chuck design increases machining space
- may be used with hard or soft top jaws

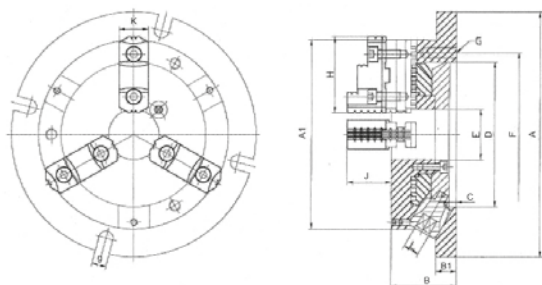

Typ / Type	A mm	A1 mm	B mm	B1 mm	D mm	F mm	E mm	C mm	G mm	H mm	K mm	J mm	L mm	g mm	Spannbereich / Clamp. range mm	kg	Art.-Nr. / Order no.
170	220	170	58	18	130	147	45	6	3-M10	68	26	40	10	13	8-160	12	ZE-SDF3-170
210	270	210	65	20	155	172	60	6	3-M10	82	28	43	11	13	11-200	20	ZE-SDF3-210
255	315	255	73	20	190	210	80	6	3-M12	93	32	52	12	16	12-250	30	ZE-SDF3-255
305	370	305	80	22	250	285	105	5	3-M12	118	40	59	14	18	15-300	47	ZE-SDF3-305

Inkl. Bedienschlüssel / Incl. wrench

Stationäre Vierbacken-Drehfutter Stationary four-jaw lathe chuck

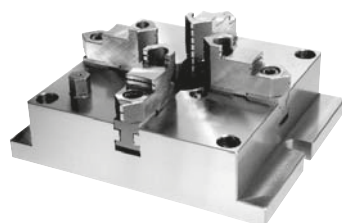

- sichere Spannung des Werkstücks (Genauigkeit 0,03 mm)
- hohe Werkstücke können aufgrund der niedrigen Bauweise ebenfalls gespannt werden
- rechtwinklige Werkstücke können paarweise mit zwei Backen gespannt werden
- mit Schmutzabdeckung
- mit Durchgangsbohrung für das Spannen langer Werkstücke
- der Bedienschlüssel wird vertikal angesetzt
- mehrere Futter können kombiniert werden
- safe gripping of work piece (precision within 0,03 mm)
- large work pieces can be held thanks to low profile body
- able to grip square work pieces by using this chuck as a two-way jaw unit
- with dirt cover
- with thru bore
- handle is set on the face and does not interfere with the table
- several chucks may be combined

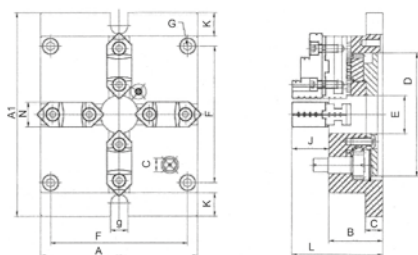

Typ / Type	A mm	A1 mm	F mm	g mm	K mm	N mm	D mm	E mm	C mm	B mm	L mm	J mm	G mm	Spannbereich / Clamp. range mm	kg	Art.-Nr. / Order no.
165	165	215	144	18	25	26	130	40	18	57	96	39	4-M10	4-128	14	ZE-SDF4-165
200	200	250	174	18	25	28	160	55	20	65	108	43	4-M12	5-162	22	ZE-SDF4-200
250	250	310	218	18	30	32	200	70	22	72	122	50	4-M14	6-200	36	ZE-SDF4-250
310	310	380	274	22	35	40	260	100	25	85	141	56	4-M16	10-265	62	ZE-SDF4-310

Passende Aufsatzbacken siehe Seiten 24 und 25
Suitable jaws see pages 24 and 25



Stationäre Drehfutter Stationary lathe chucks



Dreibacken-Drehfutter mit Winkeltrieb Three-jaw lathe chuck with angle drive

- Winkeltrieb mit zweifacher Bedienmöglichkeit
- geringe Bauhöhe des Futter für mehr Arbeitsraum
- harte und weiche Aufsatzbacken können eingesetzt werden
- angle drive with dual operation
- extra thin chuck design increases machining space
- may be used with hard or soft top jaws

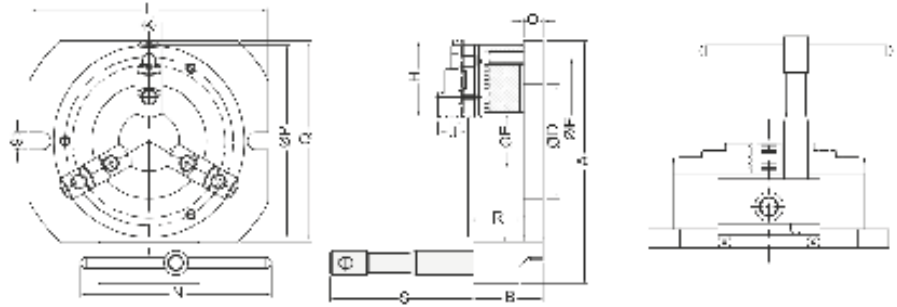

Typ / Type	A	B	D	F	E	O	G	H	S	K	J	L	g	N	P	Q	R	Spannbereich / Clamp. range mm	kg	Art.-Nr. / Order no.
150	219	83	90	147	45	20	3-M10	72	150	26	39	215	18	200	165	175	67	8-160	18	ZE-SDF3WT-150
200	254	83	120	176	58	20	3-M10	82	150	28	43	250	18	200	200	200	76,5	8-180	25	ZE-SDF3WT-200
250	327	83	190	250	87	24	3-M12	100	150	35	50	324	18	200	273	283	87	12-260	49	ZE-SDF3WT-250
300	364	83	220	285	105	24	3-M12	114	150	40	56	360	18	200	310	320	96	15-300	64	ZE-SDF3WT-300

**Inkl. Vierbacken-Drehfutter auf Anfrage lieferbar
Incl. four-jaw lathe chuck available upon request**



Drehfutter auf Drehplatte

Lathe chucks on swivel plate

Dreibacken-Drehfutter auf Drehplatte

Three-jaw chuck with swivel base

- 360° Skala
- einfache Handhabung
- für stationäre Anwendungen

- 360° scale
- smooth swivel motion and easy handling
- for stationary use

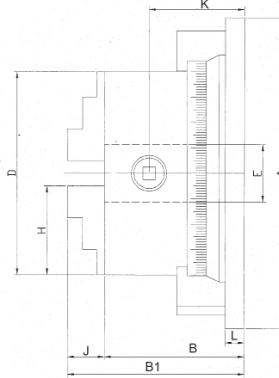
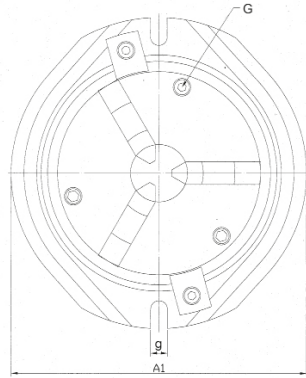
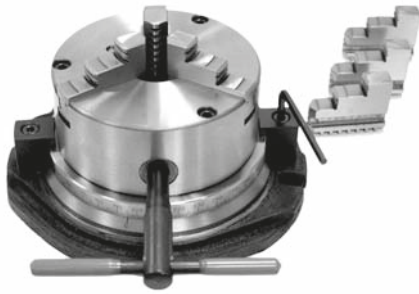

Typ / Type	A mm	A1 mm	B1 mm	B mm	D mm	E mm	L mm	H mm	G mm	K mm	J mm	g mm	kg	Art.-Nr. / Order no.
160	245	233	139	110	160	45	15	70	3-M8	69	29	14	18	ZE-1300-160
200	305	270	159	125	200	65	20	86	3-M10	75	34	18	31	ZE-1300-200

Inkl. je 1 Satz Dreh- und Bohrbacken, Bedienschlüssel / Incl. 1 set each of solid jaws internally / externally stepped, wrench

Vierbacken-Drehfutter auf Drehplatte

Four-jaw chuck with swivel base

- 360° Skala
- einfache Handhabung
- für stationäre Anwendungen

- 360° scale
- smooth swivel motion and easy handling
- for stationary use

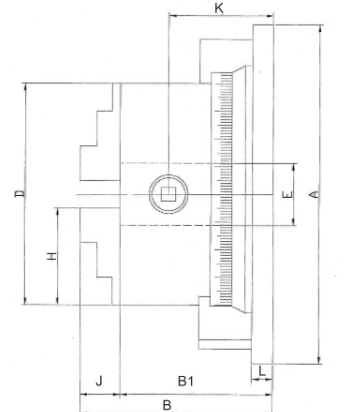
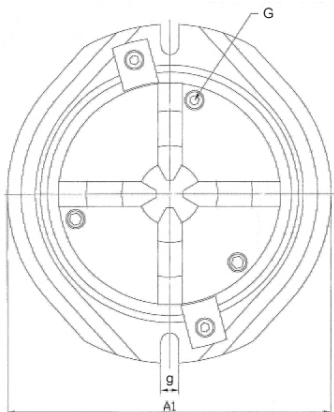
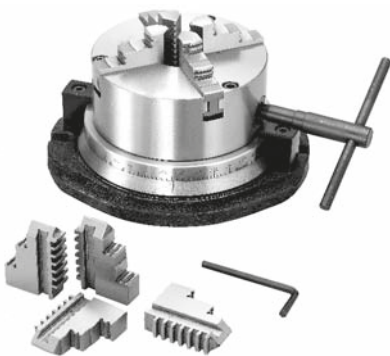

Typ / Type	A mm	A1 mm	B1 mm	B mm	D mm	E mm	L mm	H mm	G mm	K mm	J mm	g mm	kg	Art.-Nr. / Order no.
160	245	233	139	110	160	45	15	70	3-M8	69	29	14	18	ZE-1400-160
200	305	270	159	125	200	65	20	86	3-M10	75	34	18	31	ZE-1400-200

Inkl. je 1 Satz Dreh- und Bohrbacken, Bedienschlüssel / Incl. 1 set each of solid jaws internally / externally stepped, wrench

Prismenblöcke V-blocks

Prismenblöcke mit Spannbügel V-blocks with clamping bracket



- geeignet zum Spannen von Rundmaterial
- 1 Prisma, 90°
- Spezialstahl gehärtet 52 - 58 HRC
- Parallelität: 0,005 / 100 mm
- Rechtwinkligkeit: 0,005 / 100 mm
- Lieferung paarweise
- suitable for clamping round material
- one V-groove 90°
- hardened special steel 52 - 58 HRC
- parallelism: 0,005 / 100 mm
- squareness: 0,005 / 100 mm
- delivered in pairs

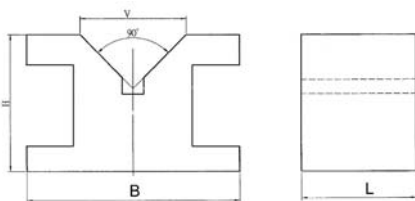

B mm	L mm	H mm	V mm	Art.-Nr. / Order no.
35	35	30	11,5	14-PPSB-35
60	60	50	30	14-PPSB-60
75	100	75	60	14-PPSB-75
105	105	78	60	14-PPSB-105

Preis pro Paar / Price per pair

Prismenblöcke V-blocks

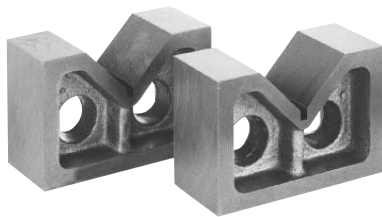

- aus Spezialguss
- prismatischer Einschnitt 90°
- Lieferung paarweise
- special cast iron
- V-groove 90°
- delivered in pairs

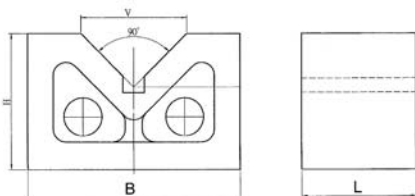

B mm	L mm	H mm	V mm	Art.-Nr. / Order no.
50	27	32	25	14-PP-50
76	35	61	44	14-PP-76
100	45	67	53	14-PP-100
130	51,5	79,5	64	14-PP-130
156	66	90,5	81	14-PP-156
181	77	110	85,4	14-PP-181
206	103	143	116	14-PP-206

Preis pro Paar / Price per pair

Prismenblöcke magnetisch, mit Schalter Magnetic V-blocks, switchable



- Paarweise bearbeitet
- mit Schalter
- gehärteter Stahl
- 90° Prisma
- Rechtwinkligkeit: 0,02 / 100 mm
- Lieferung paarweise
- machined in pairs
- with switch
- hardened steel
- 90° V-groove
- squareness: 0,02 / 100 mm
- delivered in pairs

Größe / Size mm L x B x H	Für / for Ø mm	Magnetkraft / Magnetic force kg	Art.-Nr. / Order no.
70 x 40 x 50	6-38	15	14-PPMS-70
100 x 50 x 80	6-44	20	14-PPMS-100
150 x 50 x 100	6-40	23	14-PPMS-150

Preis pro Paar / Price per set

Lagerstandard / in stock
innerhalb weniger Tage / within a few days
auf Anfrage / on request
auslaufende Größe / as stock lasts



Prismenblöcke V-blocks

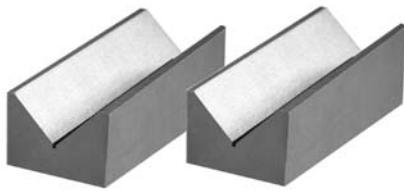

Prismenpaare V-block pairs

- paarweise geschliffen
- gehärteter Spezialstahl
- prismatischer Einschnitt 90°
- Lieferung paarweise
- machined in pairs
- hardened special steel
- V-groove 90°
- delivered in pairs

L x B x H / L x W x H mm	Güte / Grade	Für / for Ø mm	Genauigkeit / Accuracy mm	Art.-Nr. / Order no.
75 x 40 x 30	0	5-40	± 0,008	14-PBL-75/0
100 x 47 x 40	0	5-55	± 0,008	14-PBL-100/0
150 x 55 x 45	0	5-60	± 0,008	14-PBL-150/0
200 x 65 x 55	0	5-75	± 0,008	14-PBL-200/0
75 x 40 x 30	1	6-40	± 0,016	14-PBL-75/1
100 x 40 x 30	1	6-50	± 0,016	14-PBL-100/1
150 x 50 x 40	1	8-60	± 0,016	14-PBL-150/1
200 x 70 x 50	1	8-70	± 0,016	14-PBL-200/1
75 x 40 x 30	3	6-40	± 0,064	14-PBL-75/3
100 x 40 x 30	3	6-50	± 0,064	14-PBL-100/3
150 x 50 x 40	3	8-60	± 0,064	14-PBL-150/3
200 x 70 x 50	3	8-70	± 0,064	14-PBL-200/3

Preis pro Paar / Price per set

Winkelprismen Angle prisms

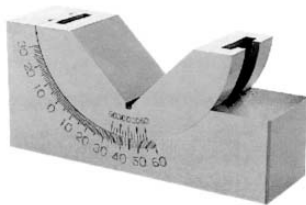

Winkelprismen, einstellbar Angle prisms, adjustable

- prismatischer Einschnitt 90°
- Stahl, 58 - 64 HRC
- Rechtwinkligkeit: ± 0,01 mm
- Winkel einstellbar von -30° bis +60°
- V-groove 90°
- high carbon steel, 58 - 64 HRC
- squareness: ± 0,01 mm
- angle adjustable from -30° to +60°

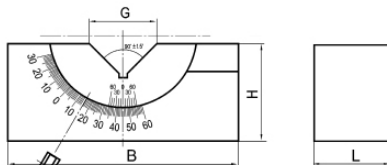

L mm	B mm	H mm	G mm	kg	Art.-Nr. / Order no.
25	75	33	25	0,5	14-WPE-25
30	102	30	46	1	14-WPE-30
46	102	46	46	1,5	14-WPE-46

Preis pro Stück / Price per piece

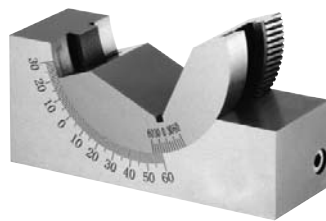

Winkelprismen, einstellbar mit Schneckengetriebe Angle prisms, adjustable by worm gear

- prismatischer Einschnitt 90°
- Stahl, 50 - 54 HRC
- Rechtwinkligkeit: ± 0,01 mm
- Winkel einstellbar von -30° bis +60° mit Schneckengetriebe
- V-groove 90°
- steel, 50 - 54 HRC
- squareness: ± 0,01 mm
- angle adjustable from -30° to +60° by worm gear

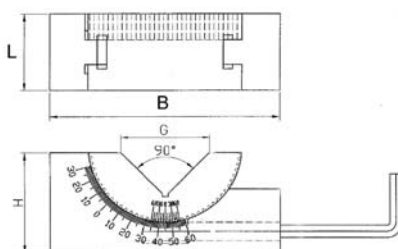

L mm	B mm	H mm	G mm	kg	Art.-Nr. / Order no.
25	75	32	29,5	0,5	14-WPESG-25
30	102	47	51,9	1	14-WPESG-30
46	102	47	53,4	1,4	14-WPESG-46

Preis pro Stück / Price per piece



Schraubböcke Levelling screws



Schraubböcke Levelling screws

Bereich / Range mm	D mm	C mm	kg	Art.-Nr. / Order no.
65-90	38	28,5	0,5	14-NVS-95
90-140	50	40	1,2	14-NVS-150
140-230	53	45	2,3	14-NVS-230
265-360	73	45	4,6	14-NVS-375

Preis pro Stück / Price per piece



Schraubböcke magnetisch Magnetic levelling screws

Bereich / Range mm	D mm	C mm	kg	Art.-Nr. / Order no.
42-47	40	35	0,4	14-NVSM-50
51-65	40	35	0,5	14-NVSM-65
67-87	45	40	0,7	14-NVSM-85
86-116	45	40	0,7	14-NVSM-110
110-170	50	45	1,4	14-NVSM-165

Preis pro Stück / Price per piece

Permanentmagnet-Spannplatten

Permanent magnetic plates

- für Fräs- und Schleifarbeiten
 - Erzeugung der Magnetkraft durch Permanentmagnete
 - mit enger Querspolteilung
 - Ein- / Ausschalten über 6-Kant-Schlüssel
 - Haftkraft bis zu 100 N/cm²
- for milling and grinding operations
 - generation of magnetic force by permanent magnets
 - narrow pole pitch
 - on/off-operation by hexagonal wrench
 - holding force up to 100 N/cm²

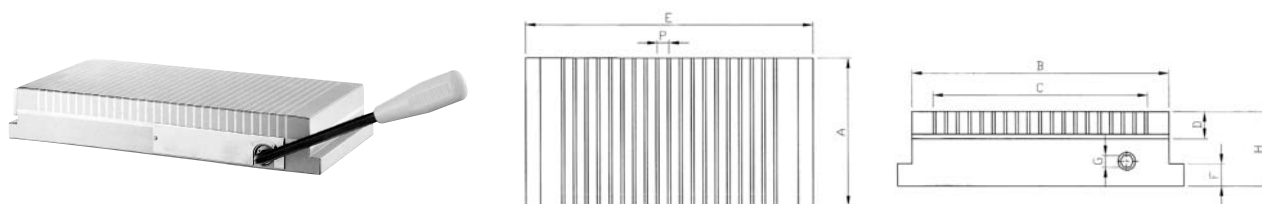

Größe / Size mm	A mm	B mm	C mm	D mm	P mm	G mm	E mm	F mm	H mm	kg	Art.-Nr. / Order no.
100x175	100	175	146	20	8 (2+6)	8	187	15	50	8	● 14-PMP18-100/175
125x250	125	250	206	20	8 (2+6)	8	262	15	50	15	● 14-PMP18-125/250
150x300	150	300	256	20	8 (2+6)	8	318	15	50	19	● 14-PMP18-150/300
150x450	150	450	406	20	8 (2+6)	8	468	15	50	28	● 14-PMP18-150/450
200x400	200	400	365	20	8 (2+6)	8	418	15	50	32	● 14-PMP18-200/400
250x500	250	500	456	20	8 (2+6)	8	518	15	50	50	● 14-PMP18-250/500
300x600	300	600	550	18	8 (2+6)	8	620	15	48	74	● 14-PMP18-300/600

Permanentmagnet-Rundfutter

Round permanent magnetic chucks

- für Dreh- und Schleifmaschinen, Teilapparate und Rundtische
 - Erzeugung der Magnetkraft durch Permanentmagnete
 - Ein- / Ausschalten über Schlüssel
 - Haftkraft bis zu 100 N/cm²
- for turning and grinding machines, dividing heads and rotary tables
 - generation of magnetic force by permanent magnets
 - on/off-operation by wrench
 - holding force up to 100 N/cm²

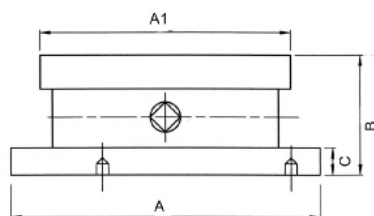
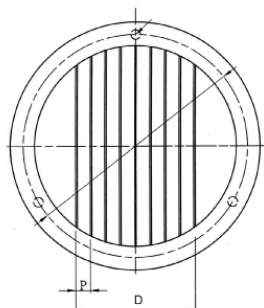

A1 mm	D mm	C mm	A mm	P mm	B mm	kg	Art.-Nr. / Order no.
150	101	18	200	9 (2+7)	78	9	● 14-PMPRD18-150
200	137	18	200	9 (2+7)	78	13	● 14-PMPRD18-200
250	191	18	250	9 (2+7)	78	20	● 14-PMPRD18-250
300	227	18	305	9 (2+7)	78	31	● 14-PMPRD18-300

Klauenkästen Box jaws

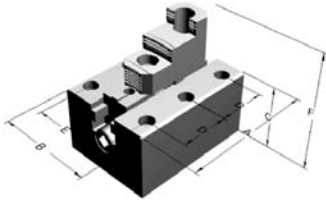

Satz à 4 Stück / Set of 4 pcs.

- Material: Stahl

- material: steel

Typ / Type	A mm	B mm	C mm	D mm	E mm	F mm	H mm	Art.-Nr. / Order no.
1	220	160	114	80	120	207	60	14-KLK-220
2	280	200	124	110	150	218,5	70	14-KLK-280
3 *	345	265	135	142,5	190	247,5	80	14-KLK-345
4 *	400	320	160	150	240	255	90	14-KLK-400

* mit 1 Stufe / with 1 step

Sonderanfertigungen auf Anfrage
Special sizes available upon request

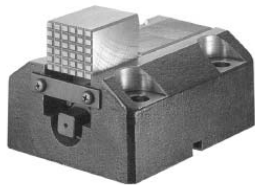

Strong AUTO

HB4-160, Satz à 4 Stück / set of 4 pcs.

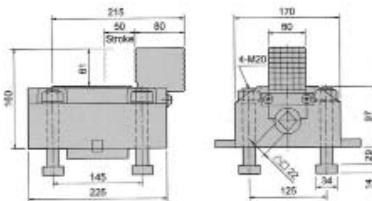

Höhe / Height mm	Backenhub / Jaw stroke mm	Max. Spannkraft / Max. gripping force kN	kg	Art.-Nr. / Order no.
160	50	39,2	29	29-HB4-160

HB4-189, Satz à 4 Stück / set of 4 pcs.

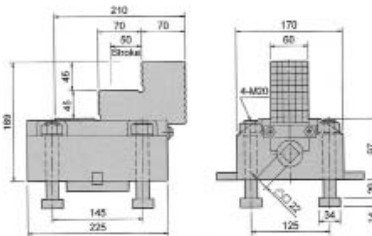

Höhe / Height mm	Backenhub / Jaw stroke mm	Max. Spannkraft / Max. gripping force kN	kg	Art.-Nr. / Order no.
189	50	39,2	31	29-HB4-189

HB4-2P, Satz à 4 Stück / set of 4 pcs.

- mit geteilten Backen

- with two-piece jaws

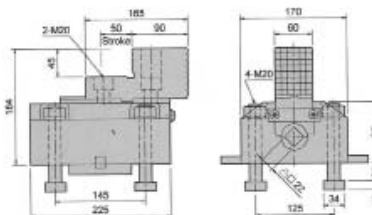

Höhe / Height mm	Backenhub / Jaw stroke mm	Max. Spannkraft / Max. gripping force kN	kg	Art.-Nr. / Order no.
184	50	39,2	31	29-HB4-2P

Kreuz- und Schiebetische

Cross and slide tables

BAZIS



Typ CP Type CP

Stationäre Schiebetische mit einer Achse.

Stationary slide tables with 1 axis.

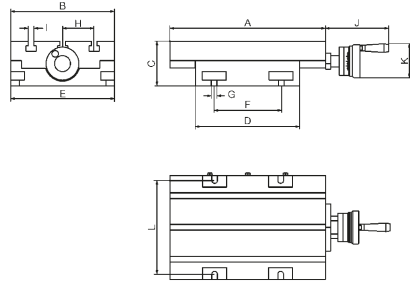

Typ CP / Type CP	A mm	B mm	C mm	D mm	E mm	F mm	G mm	H mm	I mm	J mm	K mm	L mm	T-Nuten / T-nuts
CP-0	230	164	66	164	164	-	-	50	10	56	56	-	3
CP-1	330	220	94	220	220	140	12	67	12	137	70	198	3
CP-2	430	240	100	260	240	150	16	72	12	135	70	216	3
CP-3	600	240	98	310	240	200	16	72	12	135	70	216	3
CP-4	800	240	110	415	240	300	16	72	12	140	100	216	3
CP-5	800	320	104	415	320	300	16	72	12	140	100	300	4

Typ CP / Type CP	X-Verfahrweg / X-Travel mm	Auflösung / Resolution mm	Gewinde- steigung / Thread lead	Max. Werkstückgewicht / Max. weight of work p. kg	Max. Arbeitsdruck / Max. pressure kg	kg	Art.-Nr. / Order no.
CP-0	70	0,05	2	55	500	10	● 18-CP-0
CP-1	110	0,05	4	105	700	25	● 18-CP-1
CP-2	170	0,05	4	270	900	35	● 18-CP-2
CP-3	290	0,05	4	270	980	45	● 18-CP-3
CP-4	385	0,05	4	290	1200	62	▶ 18-CP-4
CP-5	385	0,05	4	290	1200	85	▶ 18-CP-5

Typ MF Type MF

BAZIS



Stationäre Koordinatentische mit zwei Achsen.

Stationary cross tables with 2 axes.

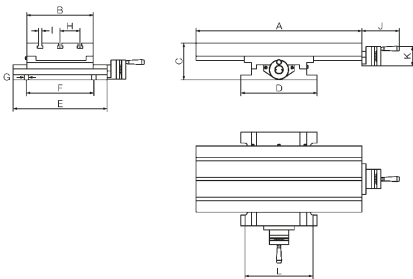

Typ MF / Type MF	A mm	B mm	C mm	D mm	E mm	F mm	G mm	H mm	I mm	J mm	K mm	L mm	T-Nuten / T-nuts
MF-0	230	164	101	225	225	160	12	50	10	56	56	191	3
MF-1	330	220	125	256	280	210	16	67	12	137	70	210	3
MF-2	430	240	132	276	340	244	16	72	12	135	70	246	3
MF-3	600	240	133	276	340	244	16	72	12	135	70	246	3

Typ MF / Type MF	X-Verfahrweg / X-Travel mm	Y-Verfahrweg / Y-Travel mm	Auflösung / Resolution mm	Gewinde- steigung / Thread lead	Max. Werkst.gewicht / Max. weight of work p. kg	Max. Arbeitsdruck / Max. pressure kg	kg	Art.-Nr. / Order no.
MF-0	120	110	0,05	2	55	500	16	● 18-MF-0
MF-1	190	130	0,05	4	105	700	33	● 18-MF-1
MF-2	240	160	0,05	4	270	900	46	● 18-MF-2
MF-3	350	160	0,05	4	270	980	56	● 18-MF-3



Kreuztische Cross tables

BAZIS



Typ MF DRILL Type MF DRILL

Stationäre Kreuztische mit zwei Achsen und zwei zusätzlichen Anschlägen für den X-Verfahrweg.

Stationary cross tables with 2 axes and additionally with 2 stops for X-travel.

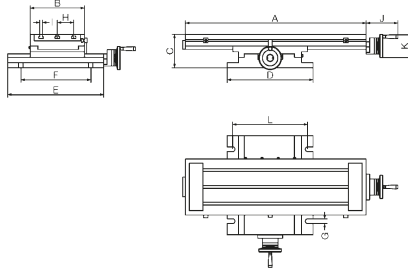

Typ MF DRILL / Type MF DRILL	A mm	B mm	C mm	D mm	E mm	F mm	G mm	H mm	I mm	J mm	K mm	L mm	T-Nuten / T-nuts
MF-2 Drill	430	240	133	276	340	244	16	72	12	140	100	246	3
MF-3 Drill	600	240	133	276	340	244	16	72	12	140	100	246	3
MF-4 Drill	800	240	144	380	425	310	20	72	12	140	100	332	3
MF-5 Drill	800	320	150	370	600	460	20	72	12	140	100	322	4
MF-6 Drill	800	320	229	480	800	610	20	72	12	-	100	430	4

Typ MF DRILL / Type MF DRILL	X-Verfahrweg / X-Travel mm	Y-Verfahrweg / Y-Travel mm	Auflösung / Resolution mm	Gewinde- steigung / Thread lead	Max. Werkstückgewicht / Max. weight of work p. kg	Max. Arbeits- druck / Max. pressure kg	kg	Art.-Nr. / Order no.
MF-2 Drill	240	160	0,05	4	270	900	46	● 18-MF-2DRILL
MF-3 Drill	350	160	0,05	4	270	980	56	● 18-MF-3DRILL
MF-4 Drill	470	240	0,05	4	290	1200	86	▶ 18-MF-4DRILL
MF-5 Drill	470	300	0,05	4	290	1200	122	▶ 18-MF-5DRILL
MF-6 Drill	700	400	0,05	4	900	1350	290	▶ 18-MF-6DRILL



Typ MG - drehbar Type MG - rotatable

BAZIS

Drehbare Koordinatentische mit zwei Achsen. Für mechanische Anwendungen bei denen außer der Kontrolle des X-Y Verfahrweges noch eine Rotation des Tisches von $\pm 90^\circ$ benötigt wird.

Rotating cross tables with 2 axes to enable performance of any mechanical application in which $\pm 90^\circ$ rotation of the table is required apart from X-Y control.

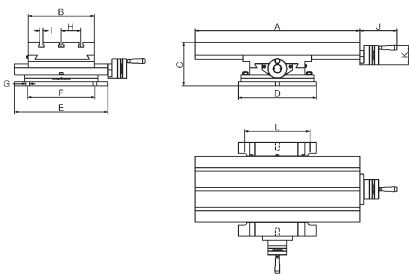

Typ MG / Type MG	A mm	B mm	C mm	D mm	E mm	F mm	G mm	H mm	I mm	J mm	K mm	L mm	T-Nuten / T-nuts
MG-0	230	164	120	213	250		12	50	10	56	56		3
MG-1	330	220	142	255	285	216	14	67	12	137	70	217	3
MG-2	430	240	150	284	340	245	16	72	12	135	70	238	3
MG-3	600	240	154	284	340	245	16	72	12	135	70	238	3
MG-4	800	240	180	368	425	305	20	72	12	140	100	338	3
MG-5	800	320	180	368	425	305	20	72	12	140	100	338	4

Typ MG / Type MG	X-Verfahrweg / X-Travel mm	Y-Verfahrweg / Y-Travel mm	Auflösung / Resolution mm	Gewinde- steigung / Thread lead	Max. Werkstückgewicht / Max. weight of work p. kg	Max. Arbeits- druck / Max. pressure kg	kg	Art.-Nr. / Order no.
MG-0	120	110	0,05	2	55	500	22	● 18-MG-0
MG-1	190	130	0,05	4	105	700	38	● 18-MG-1
MG-2	240	160	0,05	4	270	900	55	● 18-MG-2
MG-3	350	160	0,05	4	270	980	65	● 18-MG-3
MG-4	470	240	0,05	4	290	1200	113	▶ 18-MG-4
MG-5	470	300	0,05	4	290	1200	126	▶ 18-MG-5



Kreuztische MINI Cross tables MINI

BAZIS



Typ MF MINI Type MF MINI

Stationäre Koordinatentische mit zwei Achsen, entwickelt für Anwendungen in der Feinmechanik sowie für Versuchs- und Messlabore.

Stationary cross tables with 2 axes, designed for fine mechanics or laboratory applications.

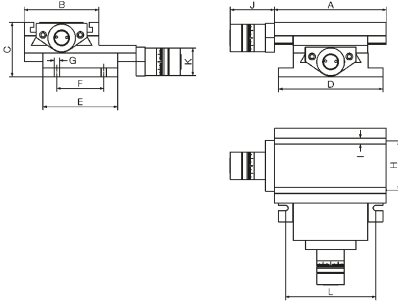

Typ MF MINI / Type MF MINI	A mm	B mm	C mm	D mm	E mm	F mm	H mm	I mm	J mm	K mm	L mm	T-Nuten / T-nuts
MF-100	150	100	73	140	100	63	66	8	60	37	121	2
MF-200	200	100	85	140	100	63	66	8	60	37	121	2

Typ MF MINI / Type MF MINI	X-Verfahrweg / X-Travel mm	Y-Verfahrweg / Y-Travel mm	Auflösung / Resolution mm	Gewindesteigung / Thread lead	Max. Werkstückgewicht / Max. weight of work p. kg	Max. Arbeitsdruck / Max. pressure kg	Art.-Nr. / Order no.
MF-100	50	50	0,025	P-1,75	40	250	● 18-MF-100
MF-200	100	100	0,025	P-1,75	40	250	● 18-MF-200



Typ MG MINI - drehbar Type MG MINI - rotatable

BAZIS

Drehbare Koordinatentische mit zwei Achsen, wie Ausführung MF MINI, jedoch mit zusätzlicher Rotationsmöglichkeit von $\pm 30^\circ$.

Rotating cross tables with 2 axes, identical to MF MINI, but with the possibility of performing $\pm 30^\circ$ rotation.

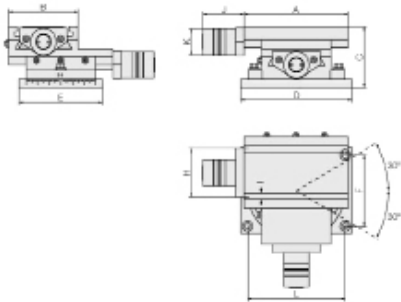

Typ MG MINI / Type MG MINI	A mm	B mm	C mm	D mm	E mm	F mm	H mm	I mm	J mm	K mm	L mm	T-Nuten / T-nuts
MG-100	150	100	85	160	120	100	66	8	60	37	140	2
MG-200	200	100	87	160	120	100	66	8	60	37	140	2

Typ MG MINI / Type MG MINI	X-Verfahrweg / X-Travel mm	Y-Verfahrweg / Y-Travel mm	Auflösung / Resolution mm	Gewindesteigung / Thread lead	Max. Werkstückgewicht / Max. weight of work p. kg	Max. Arbeitsdruck / Max. pressure kg	Art.-Nr. / Order no.
MG-100	50	50	0,025	P-1,75	45	255	● 18-MG-100
MG-200	100	100	0,025	P-1,75	45	255	● 18-MG-200

- Lagerstandard / in stock
- ▶ innerhalb weniger Tage / within a few days
- auf Anfrage / on request
- * auslaufende Größe / as stock lasts



Angetriebene Koordinatentische Driven cross tables

Typ KN Type KN

BAZUS

2
2.6

- Koordinatentische mit automatischem Positionierungssystem
 - Präzisions-Kugelrollspindeln und Turcite-Schwabenschwanzführungen
 - mit verschiedensten Motorvarianten
- Cross tables with automatic positioning system
 - precision ball-bearing spindles and Turcite-dovetail grooves
 - many different types of motors available

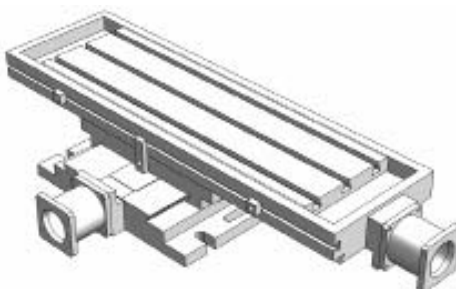

Typ KN / Type KN	X-Verfahrweg / X-Travel mm	Y-Verfahrweg / Y-Travel mm	Toleranz / Tolerance mm	Max. Werkstückgewicht / Max. weight of work p. kg	Max. Arbeitsdruck / Max. pressure kg	kg	Art.-Nr. / Order no.
KN1	190	130	± 0,01	105	700	39	18-KN-1
KN2	240	160	± 0,01	270	900	46	18-KN-2
KN3	350	160	± 0,01	270	980	56	18-KN-3
KN4	470	240	± 0,01	290	1200	86	18-KN-4
KN5	470	300	± 0,01	320	1200	122	18-KN-5
KN6	700	400	± 0,01	900	1350	290	18-KN-6



- Steuerung mit Kinematik Touchscreen oder jeder anderen CNC-Steuerung (Fanuc, Heidenhain, etc.) lieferbar auf Anfrage
- control by Kinematik touchpad or any other CNC-control system (Fanuc, Heidenhain, etc.) available upon request

**Touchscreen Steuerung optional (nicht enthalten) /
Touchscreen control unit optional (not included)**

Aufspannwinkel Angle plates



Aufspannwinkel, Typ AW Angle plates, type AW

- Spezialguss
- Rechtwinkligkeit und Parallelität: 0,01 mm / 100 mm
- special cast iron
- squareness and parallelism: 0,01 mm / 100 mm

Typ / Type	A mm	B mm	C mm	kg	Art.-Nr. / Order no.
100	102	126	150	7	38-AW-100
125	126	202	300	17	38-AW-125
150	150	150	202	15	38-AW-150
200	202	250	300	33	38-AW-200

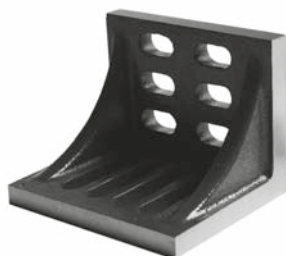
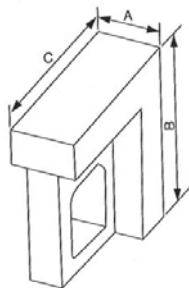

Aufspannwinkel mit Spannschlitz, Typ AWSS Angle plates with clamping slots, type AWSS

- Spezialguss
- 2-seitig bearbeitet
- Spannfläche und Standfläche mit Spannschlitz
- mit Versteifungsrippen
- Rechtwinkligkeit und Parallelität: 0,01 mm / 100 mm
- special cast iron
- machined on 2 sides
- clamping surface and base with clamping slots
- reinforced by ribs
- squareness and parallelism: 0,01 mm / 100 mm

Typ / Type	A mm	B mm	C mm	kg	Art.-Nr. / Order no.
150	150	126	115	4	38-AWSS-150
200	202	150	126	8	38-AWSS-200
250	250	202	126	12	38-AWSS-250
300	300	228	202	24	38-AWSS-300

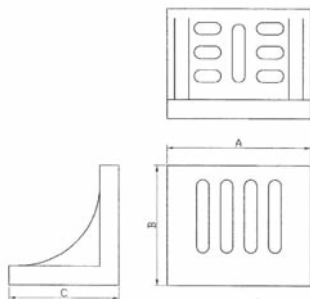

Aufspannwinkel ohne Aussparungen, Typ AWG Plain angle plates, type AWG

- Spezialguss
- 2-seitig bearbeitet
- mit Versteifungsrippen
- Rechtwinkligkeit und Parallelität: 0,01 mm / 100 mm
- special cast iron
- machined on 2 sides
- reinforced by ribs
- squareness and parallelism: 0,01 mm / 100 mm

Typ / Type	A mm	B mm	C mm	kg	Art.-Nr. / Order no.
50	51	51	51	0,4	38-AWG-50
100	102	102	102	2,5	38-AWG-100
150	152	152	152	7	38-AWG-150
250	254	254	254	28	38-AWG-250
300	305	305	305	43	38-AWG-300

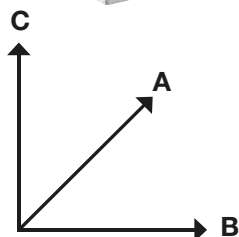

Aufspannwinkel, Typ CD23 Angle plates, type CD23

- GG 30 spannungsfrei geglüht

- GG 30 stress-annealed

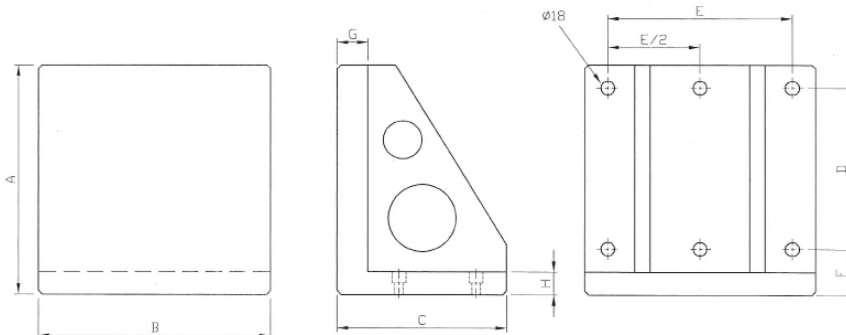

A mm	B mm	C mm	D mm	E mm	F mm	G mm	H mm	kg	Art.-Nr. / Order no.
300	300	220	100	250	90	40	30	52	38-CD23-300
400	400	280	160	320	90	40	30	90	38-CD23-400
500	500	350	200	400	90	50	35	175	38-CD23-500
630	630	450	250	500	100	50	40	305	38-CD23-630
800	800	550	320	640	115	50	45	480	38-CD23-800

Aufspannwinkel mit T-Nuten, Typ RS28 Angle plates with t-slots, type RS28

- GG 30 spannungsfrei geglüht

- GG 30 stress-annealed

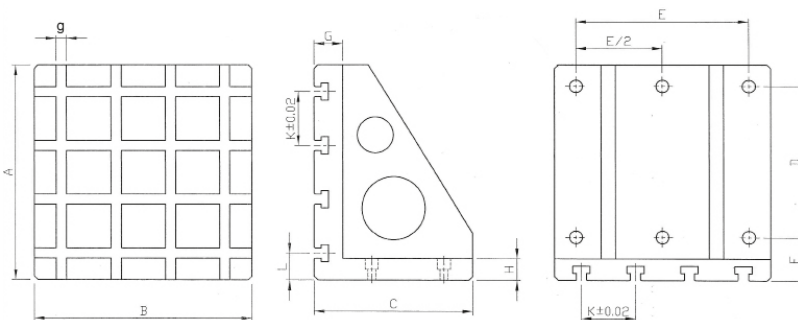

A mm	B mm	C mm	D mm	E mm	F mm	G mm	H mm	I mm	g mm	K mm ($\pm 0,02$)	L mm	kg	Art.-Nr. / Order no.
300	300	220	100	250	90	60	30	$\varnothing 18$	14	100	50	63	38-RS28-300/14
400	400	280	160	320	90	60	30	$\varnothing 18$	14	100	50	114	38-RS28-400/14
500	500	350	200	400	90	60	35	$\varnothing 18$	14	100	50	184	38-RS28-500/14
630	630	450	250	500	100	60	40	$\varnothing 18$	14	125	65	316	38-RS28-630/14
800	800	550	320	640	115	75	45	$\varnothing 18$	14	150	100	577	38-RS28-800/14
300	300	220	100	250	90	60	30	$\varnothing 18$	18	100	50	59	38-RS28-300/18
400	400	300	160	320	90	60	30	$\varnothing 18$	18	100	50	111	38-RS28-400/18
500	500	350	200	400	90	60	35	$\varnothing 18$	18	100	50	175	38-RS28-500/18
630	630	450	250	500	100	65	40	$\varnothing 18$	18	125	65	304	38-RS28-630/18

Aufspannwürfel, Typ FE50 Clamping cubes, type FE50

- GG 30 spannungsfrei gegläht

- GG 30 stress-annealed

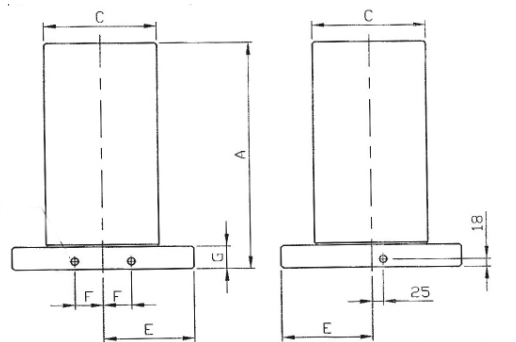
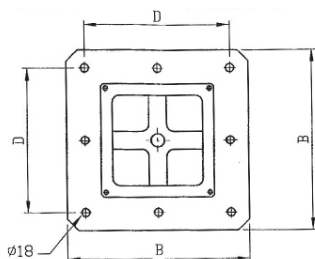

A mm	B mm	C mm	D mm	E mm	F mm	G mm	Befest.-Löcher / Fixing holes	kg	Art.-Nr. / Order no.
500	400	250	320	200	55	50	4	175	● 38-FE50-500
600	500	300	400	250	75	50	8	240	● 38-FE50-600
700	630	350	500	315	100	50	8	390	● 38-FE50-700
800	800	500	640	400	135	50	8	745	● 38-FE50-800

Rasterwürfel, Typ MS17 Locator-grid cubes, type MS17

- GG 30 spannungsfrei gegläht

- GG 30 stress-annealed

Lochraster: $\pm 0,01$ mm: 40 mm, M12/
50 mm, M16

Grid spacing: $\pm 0,01$ mm: 40 mm, M12/
50 mm, M16

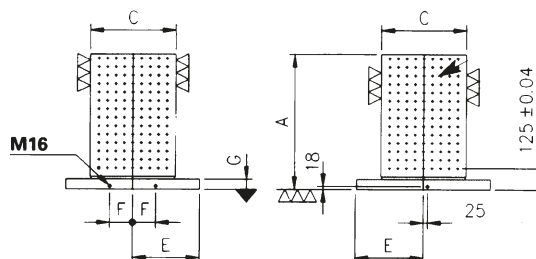
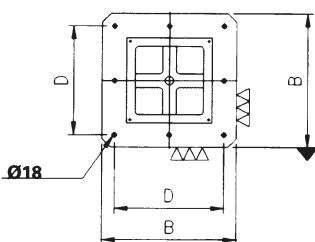
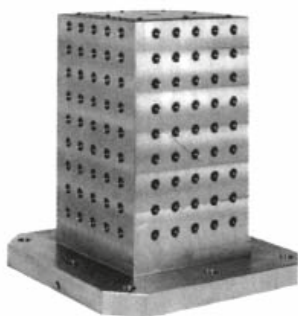

A mm	B mm	C mm	D mm	E mm	F mm	G mm	Rasterboh- rung / Grid holes (F7) Ø	Raster/ Spacing	Anz. Boh- rung / No. of holes	Befest.-Lö- cher / Fixing holes	kg	Art.-Nr. / Order no	EUR
500	400	250	320	200	55	50	12/M12	40	180	4	145	● 38-MS17-500/12	
600	500	300	400	250	75	50	12/M12	40	264	8	230	● 38-MS17-600/12	
700	630	350	500	315	100	50	12/M12	40	392	8	380	● 38-MS17-700/12	
800	800	500	640	400	135	50	12/M12	40	704	8	720	● 38-MS17-800/12	
500	400	250	320	200	55	50	16/M16	50	112	4	143	● 38-MS17-500/16	
600	500	300	400	250	75	50	16/M16	50	180	8	228	● 38-MS17-600/16	
700	630	350	500	315	100	50	16/M16	50	288	8	376	● 38-MS17-700/16	
800	800	500	640	400	135	50	16/M16	50	504	8	710	● 38-MS17-800/16	

Hülsen und Dorne

Sleeves and arbors



■ Inhalt:

- | Reduzierhülsen
- | Verlängerungshülsen
- | Bohrer- und Reibahlenverlängerungen
- | Reduzierhülsen für Hydrodehnspannfutter
- | Spindelhülsen
- | Klemmhülsen
- | Gewindebohrer-Spannhülsen
- | Gewindebohrerhalter mit Schnellwechselsystem
- | Kegeldorne

■ Content:

- | *Reducing sleeves*
- | *Extension sleeves*
- | *Drill and reamer extensions*
- | *Reducing sleeves for hydraulic expansion mandrels*
- | *Spindle sleeves*
- | *Clamping sleeves*
- | *Tap holders*
- | *Tap holders with quick change mechanism*
- | *Taper arbors*

Reduzierhülsen Reducing sleeves

DIN 2185, ganz gehärtet und geschliffen DIN 2185, completely hardened and ground



Außenkegel / External taper	Innenkegel / Internal taper	L mm	ca. g	Art.-Nr. / Order no.
1	0	80	30	01-52-1/0
2	1	92	95	01-52-2/1
3	1	99	190	01-52-3/1
3	2	112	250	01-52-3/2
4	1	124	550	01-52-4/1
4	2	124	480	01-52-4/2
4	3	140	360	01-52-4/3
5	1	156	1700	01-52-5/1
5	2	156	1520	01-52-5/2
5	3	156	1360	01-52-5/3
5	4	171	950	01-52-5/4
6	1	218	4400	01-52-6/1
6	2	218	4300	01-52-6/2
6	3	218	4100	01-52-6/3
6	4	218	3600	01-52-6/4
6	5	218	2550	01-52-6/5

Verlängerungshülsen Extension sleeves

DIN 2187, ganz gehärtet und geschliffen DIN 2187, completely hardened and ground

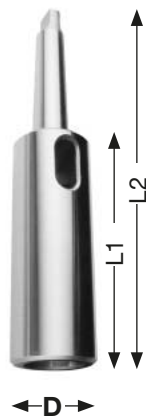

Außenkegel / External taper	Innenkegel / Internal taper	D mm	L1 mm	L2 mm	ca. g	Art.-Nr. / Order no.
1	1	20	83	145	190	01-65-1/1
1	2	30	98	160	340	01-65-1/2
2	1	20	85	160	250	01-65-2/1
2	2	30	100	175	400	01-65-2/2
2	3	36	121	196	840	01-65-2/3
2	4	48	145	220	1300	01-65-2/4
3	1	20	81	175	400	01-65-3/1
3	2	30	100	194	550	01-65-3/2
3	3	36	112	215	1000	01-65-3/3
3	4	48	146	240	1500	01-65-3/4
4	1	20	82,5	200	800	01-65-4/1
4	2	30	97,5	215	850	01-65-4/2
4	3	36	122,5	240	1300	01-65-4/3
4	4	48	147,5	265	1900	01-65-4/4
4	5	63	182,5	300	3310	01-65-4/5
5	1	20	82,5	232	1800	01-65-5/1
5	2	30	97,5	247	1900	01-65-5/2
5	3	36	118,5	268	2150	01-65-5/3
5	4	48	150,5	300	2750	01-65-5/4
5	5	63	182,5	335	4200	01-65-5/5
5	6	82	247	396	640	01-65-5/6
6	3	36	120	330	4580	01-65-6/3
6	4	48	180	355	5420	01-65-6/4
6	5	63	180	390	6750	01-65-6/5
6	6	82	241	451	11890	01-65-6/6

Sonderhülsen auf Anfrage Special sleeves available upon request

- Lagerstandard / in stock
- ▶ innerhalb weniger Tage / within a few days
- auf Anfrage / on request
- * auslaufende Größe / as stock lasts

Bohrer- und Reibahlen-Verlängerungen

Drill and reamer extensions

Ganz geschliffen, Kegel gehärtet
Completely ground, taper hardened

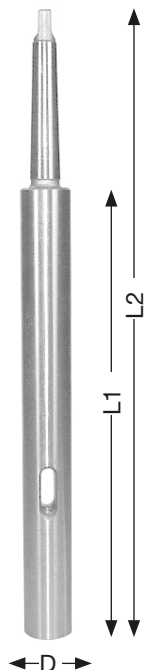

Außenkegel / External taper	Innenkegel / Internal taper	D mm	L1 mm	L2 mm	ca. g	Art.-Nr. / Order no.
1	1	20	138	200	250	01-75-1/1-200
1	1	20	188	250	375	01-75-1/1-250
1	1	20	238	300	500	01-75-1/1-300
1	1	20	288	350	625	01-75-1/1-350
1	1	20	338	400	750	01-75-1/1-400
1	1	20	388	450	900	01-75-1/1-450
1	1	20	438	500	1000	01-75-1/1-500
2	2	25	125	200	430	01-75-2/2-200
2	2	25	175	250	625	01-75-2/2-250
2	2	25	225	300	820	01-75-2/2-300
2	2	25	275	350	1015	01-75-2/2-350
2	2	25	325	400	1200	01-75-2/2-400
2	2	25	375	450	1400	01-75-2/2-450
2	2	25	425	500	1600	01-75-2/2-500
2	2	25	525	600	1800	01-75-2/2-600
3	3	32	156	250	1000	01-75-3/3-250
3	3	32	206	300	1300	01-75-3/3-300
3	3	32	256	350	1550	01-75-3/3-350
3	3	32	306	400	1850	01-75-3/3-400
3	3	32	356	450	2100	01-75-3/3-450
3	3	32	405	500	2400	01-75-3/3-500
3	3	32	506	600	2700	01-75-3/3-600
4	4	40	182,5	300	1650	01-75-4/4-300
4	4	40	232,5	350	2150	01-75-4/4-350
4	4	40	282,5	400	2650	01-75-4/4-400
4	4	40	332,5	450	3100	01-75-4/4-450
4	4	40	382,5	500	3600	01-75-4/4-500
4	4	40	482,5	600	4200	01-75-4/4-600

Sonderhülsen auf Anfrage
Special sleeves available upon request

Reduzierhülsen für Hydrodehnspannfutter

Reducing sleeves for hydraulic expansion mandrels



Für die Reduzierung des Spanndurchmessers bei Hydrodehnspannfuttern.

For diameter reduction of hydraulic expansion mandrels.

Kühlmitteldicht bis 60 bar
Mechanically sealed up to 60 bar

D mm	Bohrungen / Bores Ø mm	E mm	L mm	L1 mm	Art.-Nr. / Order no.
20	3, 4, 5, 6, 8, 10, 12, 14, 16	24	50,5	2	94-52-20/Ø
32	10, 12, 16, 18, 20, 25	36	60,5	3	94-52-32/Ø

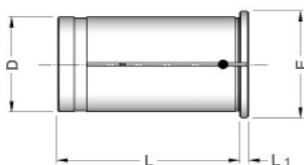

Weitere Abmessungen auf Anfrage
Further sizes available upon request

Spindelhülsen für Werkzeuge mit Morsekegel Spindle sleeves for tools with morse taper

Mit Abdrückgewinde und Mutter With draw-off thread and nut

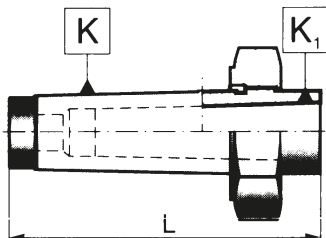

Außenkegel-MK / External taper-MT	Innenkegel-MK / Internal taper-MT	L mm	Art.-Nr. / Order no.
2*	1	84	● 01-84-2/1
3*	1	102	● 01-84-3/1
4*	1	122	● 01-84-4/1
3	2	102	● 01-84-3/2
4	2	122	● 01-84-4/2
4	3	122	● 01-84-4/3
5	2	153	● 01-84-5/2
5	3	153	● 01-84-5/3
5	4	153	● 01-84-5/4
6	3	212	✱ 01-84-6/3
6	4	212	● 01-84-6/4
6	5	212	● 01-84-6/5

* mit Austreibschlitz
* with drift slot

Spindelhülsen für Werkzeuge mit Morsekegel Spindle sleeves for tools with morse taper

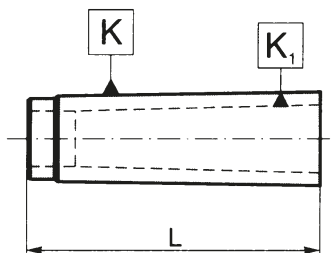

Außenkegel-MK / External taper-MT	Innenkegel-MK / Internal taper-MT	L mm	Art.-Nr. / Order no.
2	1	60	● 01-83-2/1
3	1	70	● 01-83-3/1
3	2	70	● 01-83-3/2
4	2	70	● 01-83-4/2
4	3	70	● 01-83-4/3
5	2	77	● 01-83-5/2
5	3	77	● 01-83-5/3
5	4	77	● 01-83-5/4
6	3	110	● 01-83-6/3
6	4	110	● 01-83-6/4
6	5	110	● 01-83-6/5
metrisch / metric 80	5	110	● 01-83-80/5
metrisch / metric 80	6	110	● 01-83-80/6
metrisch / metric 100	6	132	✱ 01-83-100/6

Spindelhülsen zylindrisch für Werkzeuge mit Morsekegel Cylindrical spindle sleeves for tools with morse taper



Zylindrisch / Cylindrical	Morsekegel / Morse taper	L mm	Art.-Nr. / Order no.
16	1	90	● 01-85-16/1
25	2	95	● 01-85-25/2
30	3	115	● 01-85-30/3
40	4	152	● 01-85-40/4

- Lagerstandard / in stock
- ▶ innerhalb weniger Tage / within a few days
- auf Anfrage / on request
- ✱ auslaufende Größe / as stock lasts

Klemmhülsen Clamping sleeves



Ganz gehärtet und geschliffen
Completely hardened and ground

Nach DIN 6328 für Gewindebohrer According to DIN 6328 for taps

MK / MT	Außen-Ø / External-Ø mm	L mm	Bohrung / Bore mm	Art.-Nr. / Order no.
1	12,2	65,5	2,5/2,8/ 3,5/4,0/4,5/5,0/ 5,5/6,0/7,0/8,0	● 06-501E-Ø
2	18,0	78,5	4,5/5,5/6,0/7,0/ 8,0/9,0/10,0/ 11,0/12,0/12,5	● 06-504E-Ø
3	24,0	98,0	8,0/9,0/10,0/ 11,0/12,0/ 12,5/14,0/16,0	● 06-535E-Ø
4	31,5	123,0	12,0/14,0/ 16,0/18,0/20,0/ 22,0/25,0	● 06-538E-Ø
5	44,7	156,0	22,0/25,0/28,0/ 30,0/32,0/36,0	● 06-589E-Ø

Nach DIN 6329 für Spiralbohrer According to DIN 6329 for spiral drills

MK / MT	Außen-Ø / External-Ø mm	L mm	Abmessungen / Dimensions	Steigung / Pitch mm	Art.-Nr. / Order no.
1	12,2	65,5	3,0 - 8,0	0,5	● 06-511E-Ø
2	18,0	78,5	5,0 - 13,0	0,5	● 06-514E-Ø
3	24,0	98,0	10,0 - 16,0	1,0	● 06-545E-Ø
4	31,5	123,0	12,0 - 20,0	1,0	✘ 06-548E-Ø
5	44,7	156,0	20,0 - 36,0	1,0	✘ 06-599E-Ø

Weitere Abmessungen lieferbar auf Anfrage
Further dimensions available upon request

Für Maschinen mit steigungssynchronem Vorschub

For machines with rigid tapping



- einsetzbar in herkömmlichen Weldon Spannfuttern nach DIN 1835 B
- kein Schlupf zwischen Hülse und Bohrer
- bei innerer Kühlmittelzufuhr 100% Kühlung an der Schneide
- suitable for standard Weldon chucks according to DIN 1835 B
- no slip between tap holder and drill
- 100% blade cooling if internal coolant supply is selected

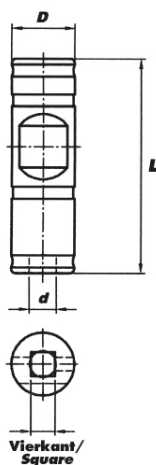

D mm	d mm	Vierkant / Square mm	L mm	Art.-Nr. / Order no.
8	2,5	2,1	27	● 81-GEW-8X2,5
8	2,8	2,1	27	● 81-GEW-8X2,8
10	3,5	2,7	35	● 81-GEW-10X3,5
10	4,0	3,0	35	● 81-GEW-10X4,0
10	4,5	3,4	35	● 81-GEW-10X4,5
12	6,0	4,9	45	● 81-GEW-12X6,0
14	7,0	5,5	45	● 81-GEW-14X7,0
14	8,0	6,2	45	● 81-GEW-14X8,0
16	9,0	7,0	48	● 81-GEW-16X9,0
16	10,0	8,0	48	● 81-GEW-16X10,0
18	11,0	9,0	48	● 81-GEW-18X11,0
20	12,0	9,0	50	● 81-GEW-20X12,0
25	14,0	11,0	56	● 81-GEW-25X14,0
25	16,0	12,0	56	● 81-GEW-25X16,0
32	18,0	14,5	60	● 81-GEW-32X18,0
32	20,0	16,0	60	● 81-GEW-32X20,0
32	22,0	18,0	60	● 81-GEW-32X22,0
40	25,0	20,0	70	● 81-GEW-40X25,0
40	28,0	22,0	70	● 81-GEW-40X28,0
50	32,0	24,0	80	● 81-GEW-50X32,0
50	36,0	29,0	80	● 81-GEW-50X36,0
50	40,0	32,0	80	● 81-GEW-50X40,0



Gewindebohrerhalter mit Schnellwechselsystem

Tap holders with quick change mechanism

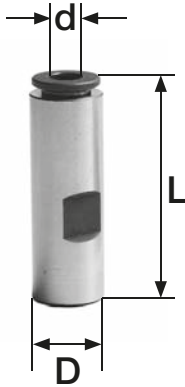

Gewindebohrerhalter mit Weldon-Spannfläche

Tap holders for weldon chucks

- mit Innenvierkant
- für den Einsatz von Gewindebohrern in Weldonfuttern
- mit Schnellwechselsystem
- with internal square
- to use tapping collets in weldon chucks
- with quick change mechanism

D mm	d mm	Vierkant / Square mm	L mm	Art.-Nr. / Order no.
16	3,5	2,7	56	● 09-GBE-16/3,5
16	4,0	3,0	56	● 09-GBE-16/4,0
16	4,5	3,4	56	● 09-GBE-16/4,5
16	6,0	4,9	56	● 09-GBE-16/6,0
20	4,5	3,4	58	● 09-GBE-20/4,5
20	6,0	4,9	58	● 09-GBE-20/6,0
20	7,0	5,5	58	● 09-GBE-20/7,0
20	8,0	6,2	58	● 09-GBE-20/8,0
20	9,0	7,0	58	● 09-GBE-20/9,0
20	10,0	8,0	58	● 09-GBE-20/10
25	4,5	3,4	66	● 09-GBE-25/4,5
25	6,0	4,9	66	● 09-GBE-25/6,0
25	7,0	5,5	66	● 09-GBE-25/7,0
25	8,0	6,2	66	● 09-GBE-25/8,0
25	9,0	7,0	66	● 09-GBE-25/9,0
25	10,0	8,0	66	● 09-GBE-25/10,0
25	11,0	9,0	66	● 09-GBE-25/11,0
25	12,0	9,0	66	● 09-GBE-25/12,0
32	6,0	4,9	70	✘ 09-GBE-32/6,0
32	7,0	5,5	70	✘ 09-GBE-32/7,0
32	8,0	6,2	70	✘ 09-GBE-32/8,0
32	9,0	7,0	70	✘ 09-GBE-32/9,0
32	10,0	8,0	70	● 09-GBE-32/10,0
32	11,0	9,0	70	● 09-GBE-32/11,0
32	12,0	9,0	70	● 09-GBE-32/12,0
32	14,0	11,0	70	● 09-GBE-32/14,0
32	16,0	12,0	70	● 09-GBE-32/16,0
32	18,0	14,5	70	● 09-GBE-32/18,0



DIN 238, Kegeldorne mit Morsekegelschaft

DIN 238, taper arbors with morse taper shanks



Ganz gehärtet und geschliffen
Completely hardened and ground

MK / MT	Kegel / Taper	L mm	ca. g	Art.-Nr. / Order no.
1	B 10	86	55	● 41-1/B10
1	B 12	90	60	● 41-1/B12
1	B 16	97	90	● 41-1/B16
1	B 18	105	110	● 41-1/B18
1	B 18 VK	97	95	✘ 41-1/B18VK
2	B 10	101	130	● 41-2/B10
2	B 12	105	135	● 41-2/B12
2	B 16	112	160	● 41-2/B16
2	B 18	120	180	● 41-2/B18
2	B 18 VK	108,5	165	✘ 41-2/B18VK
2	B 22	128	245	● 41-2/B22
3	B 12	124	280	● 41-3/B12
3	B 16	131	310	● 41-3/B16
3	B 18	139	320	● 41-3/B18
3	B 18 VK	132	320	✘ 41-3/B18VK
3	B 22	147	390	● 41-3/B22
3	B 24	157	440	● 41-3/B24
4	B 16	156	625	● 41-4/B16
4	B 18	164	660	● 41-4/B18
4	B 18 VK	159	640	✘ 41-4/B18VK
4	B 22	172	715	● 41-4/B22
4	B 24	182	770	● 41-4/B24
5	B 16	188	1600	● 41-5/B16
5	B 18	196	1600	● 41-5/B18
5	B 22	204	1650	● 41-5/B22
5	B 24	214	1700	● 41-5/B24

VK = verkürzter Bohrfutterkegel
VK = shortened drill chuck taper

Kegeldorne mit Zylinderschaft

Taper arbors with cylinder shanks

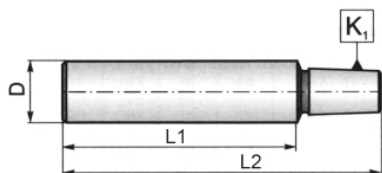

Ganz gehärtet und geschliffen
Completely hardened and ground

D mm	L1 mm	Kegel / Taper	L2 mm	Art.-Nr. / Order no.
8	35	B 10	55	● 13-5348-8-35-B10
10	50	B 10	70	● 13-5348-10-50-B10
10	50	B 12	75	● 13-5348-10-50-B12
10	50	B 16	82	● 13-5348-10-50-B16
12	50	B 16	82	● 13-5348-12-50-B16
12	60	B 16	92	● 13-5348-12-60-B16
16	50	B 16	81	● 13-5348-16-50-B16
16	70	B 16	101	● 13-5348-16-70-B16
16	70	B 18	110	✘ 13-5348-16-70-B18
20	60	B 12	87	● 13-5348-20-60-B12
20	60	B16	93	● 13-5348-20-60-B16
20	60	B 18	100	● 13-5348-20-60-B18
25	75	B 16	107	● 13-5348-25-75-B16
30	70	B 16	106	✘ 13-5348-30-70-B16
30	70	B 18	112	✘ 13-5348-30-70-B18

Kegeldorne mit Jacobs-Kegel Taper arbors with Jacobs taper

Typ 236 Type 236

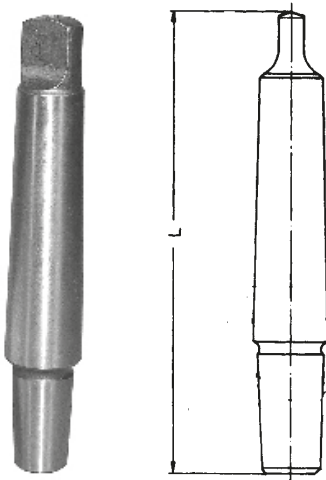

Ganz gehärtet und geschliffen
Completely hardened and ground

MK / MT	Kegel / Taper	L mm	Art.-Nr. / Order no.
1	J1	85	* 41-1/J1
1	J2	90	● 41-1/J2
1	J3	99	● 41-1/J3
1	J6	94	● 41-1/J6
2	J1	100	* 41-2/J1
2	J2	105	● 41-2/J2
2	J3	114	● 41-2/J3
2	J6	108	● 41-2/J6
3	J2	124	● 41-3/J2
3	J3	133	● 41-3/J3
3	J33	127	● 41-3/J33
3	J4	144	● 41-3/J4
3	J6	127	● 41-3/J6
4	J3	158	● 41-4/J3
4	J6	152	● 41-4/J6

Kegeldorne mit Morsekegel und Anzugsgewinde Taper arbors with morse taper and internal thread

DIN 228 A DIN 228 A

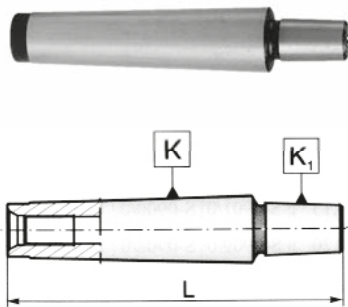

MK / MT	L mm	Gewinde / Thread	Kegel / Taper	Art.-Nr. / Order no.
2	90	M 10	B 10	● 41-2/B10-M10
2	95	M 10	B 12	● 41-2/B12-M10
2	101	M 10	B 16	● 41-2/B16-M10
3	121	M 12	B 16	● 41-3/B16-M12
4	143	M 16	B 16	● 41-4/B16-M16

Kegeldorne mit Gewinde Taper arbors with thread



MK / MT	Gewinde / Thread	L mm	kg	Art.-Nr. / Order no.
2	3/8-24	101	0,2	● 41-2-3/8-24
2	1/2-20	104	0,2	● 41-2-1/2-20
2	5/8-16	106	0,2	● 41-2-5/8-16
3	M20	122	0,4	● 41-3-3/M20

Kegelhülsen Conic bushes

Kegelhülsen, zylindrisch mit Innenkegel (MK) Conic bushes, cylindrical with internal taper (MT)

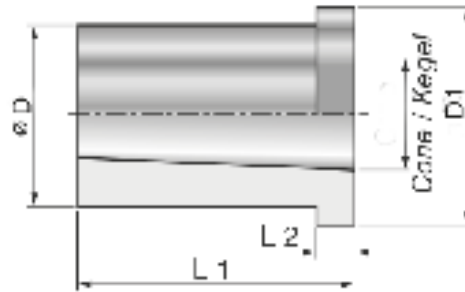
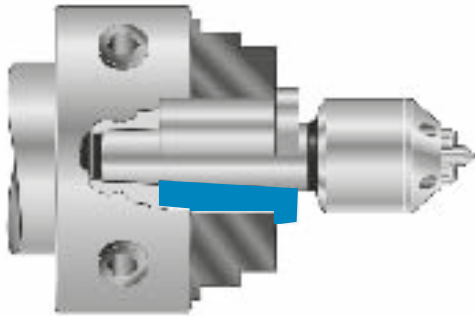

MK / MT	L1 mm	L2 mm	$\varnothing D$ mm	D1 mm	kg	Art.-Nr. / Order no.
3	65	8	35	44	0,3	▶ 03-KH-3
4	70	8	42	49	0,45	▶ 03-KH-4
5	80	10	54	59	0,6	▶ 03-KH-5
6	85	10	75	84	0,75	▶ 03-KH-6

Bohrfutter

Drill chucks



■ Inhalt:

- | Schnellspann-Bohrfutter
- | Kurzbohrfutter für Rechts- und Linkslauf
- | Kurzbohrfutter für Rechts- und Linkslauf



■ Content:

- | Keyless drill chucks
- | Universal drill chucks for right- and left-hand rotation
- | Universal drill chucks for right- and left-hand rotation



Schnellspan-Bohrfutter Keyless drill chucks



- Schnellspan-Bohrfutter, für stationäre und Handbohrmaschinen, schlüssellos
- automatische Nachspannung
- *keyless drill chucks for stationary machines and power tools*
- *self-tightening*

Spannweite / Capacity mm	Aufnahme / Mount	Durchmesser / Diameter mm	Länge / Length mm	Art.-Nr. / Order no.
0,5-6	B 10	34	72	● 44-85-6B10
0,5-8	B 12	42	82	● 44-85-8B12
1-10	B 12	42	82	● 44-85-10B12
1-10	1/2" x 20	42	86	● 44-85-10G12
1-10	3/8" x 24	42	86	● 44-85-10G38
1,5-13	1/2" x 20	44	97	● 44-85-13G12
1-13	B 16	44	97	● 44-85-13B16
3-16	B 16	54	110	● 44-85-16B16
3-16	B 18	54	110	● 44-85-16B18

Präzisions-Schnellspan-Bohrfutter High-precision keyless drill chucks



- Präzisions-Schnellspan-Bohrfutter, selbstspannend
- zum Einsatz auf Werkzeugmaschinen
- Rundlauf 0,05 mm
- *high-precision keyless drill chuck, self-tightening*
- *for high-precision machine tools*
- *run-out 0,05 mm*

Spannweite / Capacity mm	Aufnahme / Mount	Durchmesser / Diameter mm	L geöffnet / L opened mm	L geschlossen / L closed mm	g	Art.-Nr. / Order no.
0,5-8	B 10	34	61	69	320	● 44-95-8B10
0,5-8	B 12	34	61	69	320	● 44-95-8B12
0,5-10	B 12	43	81	92	705	● 44-95-10B12
0,5-10	B 16	43	81	92	705	● 44-95-10B16
0,5-13	B 16	51,5	92	103	1030	● 44-95-13B16
3-16	B 16	56	95	108	1370	● 44-95-16B16
3-16	B 18	56	95	108	1365	● 44-95-16B18

- Lagerstandard / in stock
- ▶ innerhalb weniger Tage / within a few days
- auf Anfrage / on request
- * auslaufende Größe / as stock lasts

Kurzbohrfutter, Babel

Universal drill chucks, Babel



- höchste Präzision und Rundlaufgenauigkeit: max. 0,03 mm Abweichung
- für Rechts- und Linkslauf
- hohe Spannkraft bei geringem Kraftaufwand
- sehr kurze und kompakte Bauweise, da Werkzeugenschaft und Bohrfutter eine Einheit bilden
- einfache Bedienung: schneller und unkomplizierter Werkzeugwechsel innerhalb oder außerhalb der Maschine, kein Öffnen bei schnellem Spindelstopp oder plötzlichem Richtungswechsel
- besonders geeignet zum Einsatz auf CNC-Maschinen
- Lieferumfang: Spannfutter inkl. Spannschlüssel

- high precision and concentricity: runout 0,03 mm max.
- right and left rotation
- high gripping force with minimal effort
- short and sturdy design: tool shank and chuck are forming one unit
- simple operation: quick tool change inside or outside of machine, no unintentional opening in case of sudden spindle stop or direction reversal
- suitable for CNC and high precision machine applications
- scope of delivery: drill chuck incl. wrench

Rundlaufprüfung der Babel-Bohrfutter erfolgt mit Anzugsmoment ca. 12 Nm unter Verwendung folgender Prüfdorne:
 13 mm: Ø 6 mm, 8 mm, 12 mm
 16 mm: Ø 6 mm, 8 mm, 12 mm und 16 mm

Runout test of Babel drill chucks is done with a torque of approx 12 Nm using the following test mandrels:
 13 mm: Ø 6 mm, 8 mm, 12 mm
 16 mm: Ø 6 mm, 8 mm, 12 mm und 16 mm



DIN 69871 DIN 69871

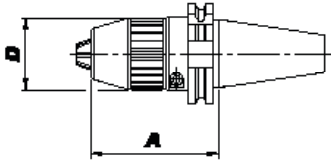

Kegel / Shank	Spannweite / Capacity mm	A mm	D mm	Art.-Nr. / Order no.
SK 40	1-13	81	45	82-691342
SK 40	1-16	87	50	82-691642
SK 50	1-13	91	45	82-691352
SK 50	1-16	97	50	82-691652



DIN 2080 DIN 2080

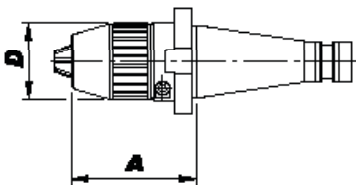

Kegel / Shank	Spannweite / Capacity mm	A mm	D mm	Art.-Nr. / Order no.
SK 40	1-13	73,5	45	82-801340
SK 40	1-16	79,5	50	82-801640
SK 50	1-16	93,5	50	82-801650



MAS-BT MAS-BT

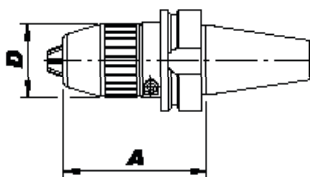

Kegel / Shank	Spannweite / Capacity mm	A mm	D mm	Art.-Nr. / Order no.
BT 40	1-13	89	45	82-701341
BT 40	1-16	95	50	82-701641
BT 50	1-16	116	50	82-701651



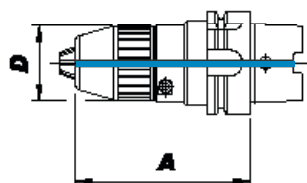

DIN 69893 - HSK
DIN 69893 - HSK

Kegel / Shank	Spannweite / Capacity mm	A mm	D mm	Art.-Nr. / Order no.
63 A	1-13	107	45	● 82-631330
63 A	1-16	112	50	● 82-631630
100 A	1-16	127	50	● 82-1001630

4

Bohrfutter / Drill chucks

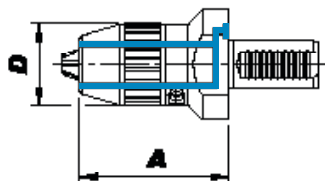

DIN 69880 (VDI) - mit Kühlmitteldüsen
DIN 69880 (VDI) - with coolant nozzles

VDI	Spannweite / Capacity mm	A mm	D mm	Art.-Nr. / Order no.
25	1-13	87	50	✘ 82-341325
30	1-13	87	50	● 82-341330
30	1-16	92	55	● 82-341630
40	1-13	88	50	● 82-341340
40	1-16	93	55	● 82-341640
50	1-16	101,5	55	● 82-341650

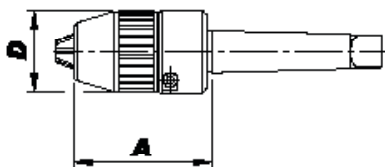

Mit Morsekegel und Austreibblappen
With morse taper and tang

MK / MT	Spannweite / Capacity mm	A mm	D mm	Art.-Nr. / Order no.
MK 3	1-16	86	50	● 82-221603
MK 4	1-16	86	50	● 82-221604
MK 5	1-16	86	50	● 82-221605



Nach ISO 26623-1 - Polygonalkegel
According to ISO 26623-1 - polygonal taper

Größe / Size	Spannweite / Capacity mm	A mm	D mm	Art.-Nr. / Order no.
6	1-13	105,4	45	✘ 82-261306
6	1-16	110,8	50	✘ 82-261606



- Rundlauf 0,03 mm
- innere Kühlmittelzufuhr
- Lieferumfang: Spannfutter inkl. Spannschlüssel

- *Runout 0,03 mm*
- *internal coolant supply*
- *scope of delivery: drill chuck incl. wrench*



DIN 69871
DIN 69871

Kegel / Shank	Spannweite / Capacity mm	A mm	D mm	Art.-Nr. / Order no.
SK 40	1-16	90	50	<input checked="" type="checkbox"/> BAS-KBF-SK40/16
SK 50	1-16	100	50	<input checked="" type="checkbox"/> BAS-KBF-SK50/16



MAS-BT
MAS-BT

Kegel / Shank	Spannweite / Capacity mm	A mm	D mm	Art.-Nr. / Order no.
BT 40	1-16	90	50	<input checked="" type="checkbox"/> BAS-KBF-BT40/16
BT 50	1-16	100	50	<input checked="" type="checkbox"/> BAS-KBF-BT50/16



DIN 69893 - HSK
DIN 69893 - HSK

Kegel / Shank	Spannweite / Capacity mm	A mm	D mm	Art.-Nr. / Order no.
HSK 63 A	1-16	100	50	<input checked="" type="checkbox"/> BAS-KBF-HSK63/16

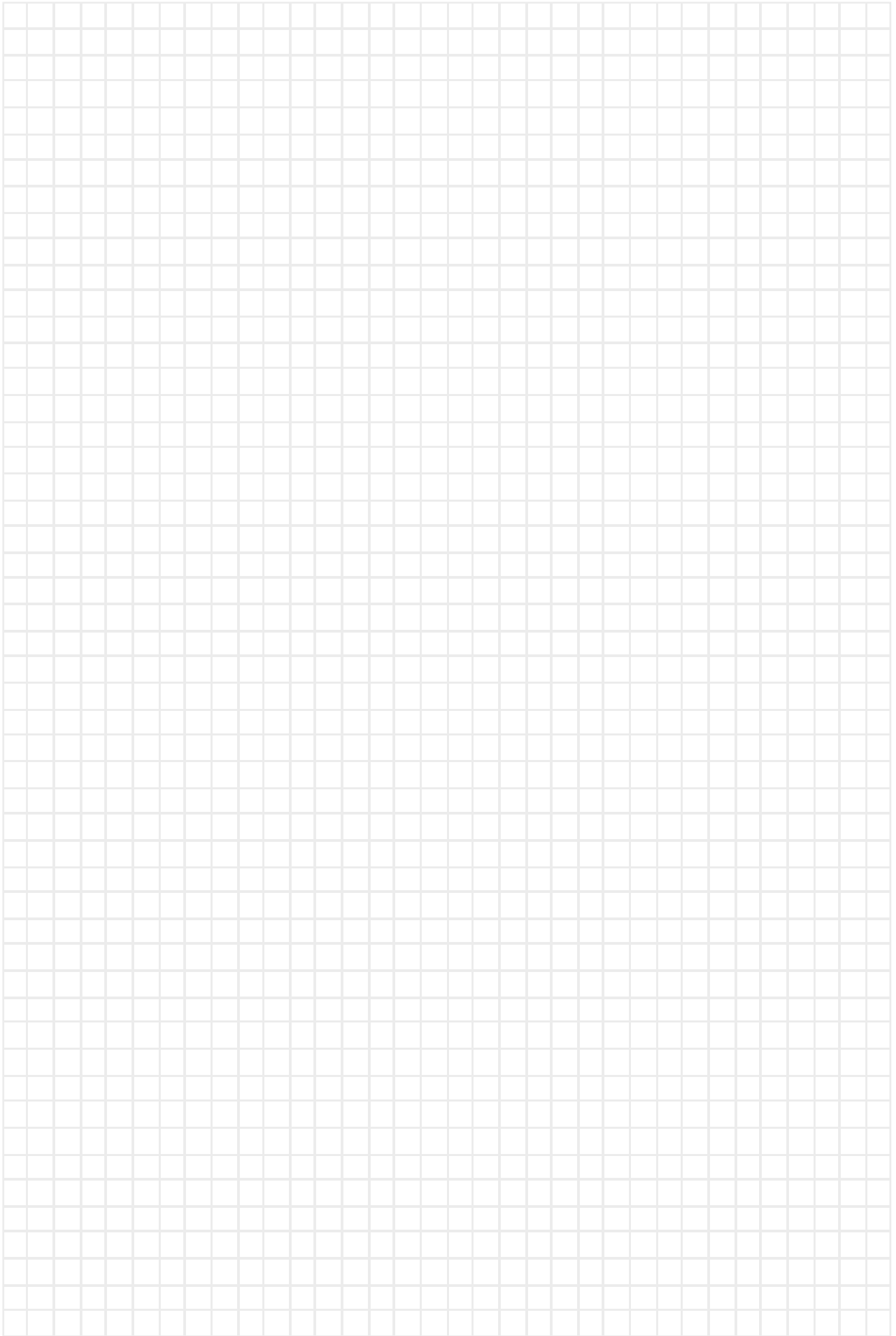

Körnerspitzen

Tailstock centres



■ Inhalt:

- | Mitlaufende Drehbankspitzen
- | Mitlauf. Drehbankspitzen für auswechselbare Einsätze
- | Mitlaufende Zentrierkegel
- | Feste Zentrierspitzen
- | Feste Zentrierkegel
- | Modulare Zentrierkegel und Futterflansche
- | **ROTOR** Rotierende Spitzen
- | Stirnmitnehmer

■ Content:

- | *Revolving tailstock centres*
- | *Revolving tailstock centres for interchangeable inserts*
- | *Revolving tube centres*
- | *Fixed centres*
- | *Fixed tube centres*
- | *Modular tube centres and chuck adaptors*
- | **ROTOR** Live-Centres
- | *Face drivers*

Serie 80 Series 80

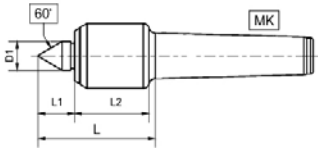

Mitlaufende Präzisions-Drehbankspitze Precision revolving tailstock centre

- stabile Konstruktion
- schaftgelagerter Körner
- kleiner Gehäusedurchmesser
- Dauerschmierung
- Gehäuse gehärtet und geschliffen
- solid design
- centre tip with needle bearings
- slim design with small casing diameter
- maintenance-free lubrication
- housing hardened and ground

Typ / Type	MK / MT	D mm	D1 mm	L mm	L1 mm	L2 mm	Drehzahl / Speed max.	Werkst. / Work piece max. kg	Rundlaufgenauigkeit / Run-out max. mm	Art.-Nr. / Order no.
82	2	32	15	64	19,5	39	6000	200	0,005	03-80-02
83	3	34	15	64	19,5	39	6000	400	0,005	03-80-03
84	4	43	20	77	27	43	6000	800	0,005	03-80-04
85	5	58	30	105	37	59	4000	1200	0,008	03-80-05

Serie 80 KOP Series 80 KOP

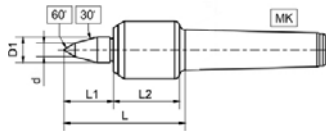

Mitlaufende Präzisions-Drehbankspitze, verlängert Precision revolving tailstock centre, extended

- wie Serie 80, aber mit verlängerter Spitze 30° / 60°
- as series 80, but with extended tip 30° / 60°

Typ / Type	MK / MT	D mm	D1 mm	L mm	L1 mm	L2 mm	d mm	Drehzahl / Speed max.	Werkst. / Work piece max. kg	Rundlaufgenauigkeit / Run-out max. mm	Art.-Nr. / Order no.
82 KOP	2	32	15	74	29	39	8	6000	150	0,005	03-80-02KOP
83 KOP	3	34	15	74	29	39	8	6000	300	0,005	03-80-03KOP
84 KOP	4	43	20	86	36	43	10	6000	700	0,005	03-80-04KOP
85 KOP	5	58	30	116	48	59	12	4000	1000	0,01	03-80-05KOP

Serie 100 Series 100

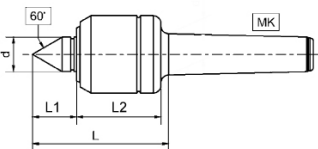

Mitlaufende Präzisions-Drehbankspitze Precision revolving tailstock centre

- Universal-Ausführung mit 3 Rillenkugellagern
- Gehäuse gehärtet und geschliffen
- Körner aus chromlegiertem Werkzeugstahl
- hohe Rundlaufgenauigkeit
- besonders leichter Lauf
- wartungsfreie Dauerschmierung
- universal centre with 3 groove ball bearings
- housing hardened and ground
- centre tip from chromium-alloyed tool steel
- high concentricity
- easy and smooth running
- maintenance-free permanent lubrication

Typ / Type	MK / MT	D mm	d mm	L mm	L1 mm	L2 mm	Drehzahl / Speed max.	Werkst. / Work piece max. kg	Rundlaufgenauigkeit / Run-out max. mm	Art.-Nr. / Order no.
111	1	28	12	57,5	17	34	6500	25	0,005	03-111
113	1	35	13	63,5	18	39	5500	50	0,005	03-113
121	2	35	13	66	19	39	5500	80	0,005	03-121
123	2	45	20	84	26	49	5000	100	0,005	03-123
131	3	45	20	84	26	49	5000	150	0,005	03-131
133	3	60	24	103	34	60	4000	300	0,005	03-133
141	4	60	24	105	34	60	4000	400	0,005	03-141
143	4	76	32	126	42	73	3200	650	0,008	03-143

- Lagerstandard / in stock
- ▶ innerhalb weniger Tage / within a few days
- auf Anfrage / on request
- * auslaufende Größe / as stock lasts

Serie 100 KOP Series 100 KOP

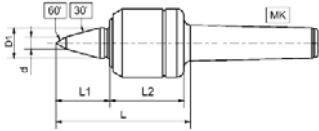

Mitlaufende Präzisions-Drehbankspitze, verlängert Precision revolving tailstock centre, extended

- wie Serie 100, aber mit verlängerter Spitze 30° / 60°
- as series 100, but with extended tip 30° / 60°

Typ / Type	MK / MT	D mm	D1 mm	L mm	L1 mm	L2 mm	d mm	Drehzahl / Speed max.	Werkst. / Work piece max. kg	Rundlaufgenauigkeit / Run-out max. mm	Art.-Nr. / Order no.
123 KOP	2	45	20	94	36	49	8	5000	100	0,005	03-123KOP
131 KOP	3	45	20	94	36	49	8	5000	150	0,005	03-131KOP
133 KOP	3	60	24	110	46	60	10	4000	300	0,005	03-133KOP
141 KOP	4	60	24	117	46	60	10	4000	400	0,005	03-141KOP
143 KOP	4	76	32	139	55	73	12	3200	650	0,008	03-143KOP

Serie 800 Series 800

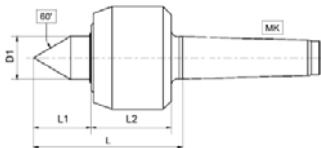

Mitlaufende Präzisions-Drehbankspitze Precision revolving tailstock centre

- schaftgelagerter Körner aus chromlegiertem Werkzeugstahl von hoher Verschleißfestigkeit
- ganzes Gehäuse gehärtet und geschliffen
- mit starkem Längslager und doppelreihigem Schrägkugellager
- hohe Rundlaufgenauigkeit, wartungsfreie Dauerschmierung
- optimale Abdichtung gegen Eindringen von Kühlmittel und Schmutz
- centre tip from chromium-alloyed tool steel with high wear resistance
- housing completely hardened and ground
- with strong axial bearing and double-row angular ball bearings
- high concentricity, maintenance-free permanent lubrication
- optimum sealing to avoid penetration of coolant and dirt

Typ / Type	MK / MT	D mm	D1 mm	L mm	L1 mm	L2 mm	Drehzahl / Speed max.	Werkst. / Work piece max. kg	Rundlaufgenauigkeit / Run-out max. mm	Art.-Nr. / Order no.
823	2	45	20	76	26	43	5000	150	0,005	03-823
831	3	45	20	77	26	43	5000	200	0,005	03-831
833	3	60	24	95	36	52	4300	400	0,005	03-833
841	4	60	24	97	36	52	4300	600	0,005	03-841
843	4	76	32	112	43	60	3200	750	0,005	03-843
851	5	78	32	118	47	60	3200	1800	0,005	03-851
853	5	96	42	134	49	74	2600	2000	0,007	03-853
863	6	110	52	155	62	82	2000	4500	0,01	03-863

Serie 800 KOP Series 800 KOP

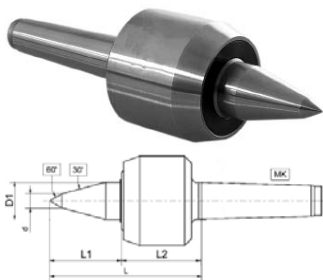

Mitlaufende Präzisions-Drehbankspitze, verlängert Precision revolving tailstock centre, extended

- wie Serie 800, aber mit verlängerter Spitze 30° / 60°
- as series 800, but with extended tip 30° / 60°

Typ / Type	MK / MT	D mm	D1 mm	L mm	L1 mm	L2 mm	d mm	Drehzahl / Speed max.	Werkst. / Work piece max. kg	Rundlaufgenauigkeit / Run-out max. mm	Art.-Nr. / Order no.
823 KOP	2	45	20	87	37	43	8	5000	100	0,005	03-823KOP
831 KOP	3	45	20	88	37	43	8	5000	150	0,005	03-831KOP
833 KOP	3	60	24	106	47	52	10	4300	300	0,005	03-833KOP
841 KOP	4	60	24	107	47	52	10	4300	400	0,005	03-841KOP
843 KOP	4	76	32	130	61	60	12	3200	600	0,005	03-843KOP
851 KOP	5	78	32	132	61	60	12	3200	1200	0,005	03-851KOP
853 KOP	5	96	42	157	71	74	16	2600	1400	0,007	03-853KOP
863 KOP	6	110	52	178	86	82	20	2000	2500	0,01	03-863KOP

Serie 805 Series 805

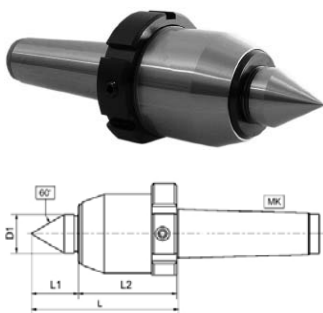

Mitlaufende Hochleistungs-Drehbankspitze High performance revolving tailstock centre

- speziell für NC-Drehmaschinen mit Abdrückmutter
- ganz gehärtet und geschliffen
- Körner schaftgelagert in Präzisions-Nadellager
- für hohe Drehzahlen bei optimalem Rundlauf
- Dauerschmierung
- mit Zusatzdichtung auch für Schleifmaschinen geeignet
- especially developed for use on NC machines with draw-off nut
- completely hardened and ground
- centre tip supported by needle bearings for high speeds with optimum concentricity
- permanent lubrication
- with additional sealing also suitable for grinding machines

Typ / Type	MK / MT	D mm	D1 mm	L mm	L1 mm	L2 mm	Drehzahl / Speed max.	Werkst. / Work piece max. kg	Rundlaufgenauigkeit / Run-out max. mm	G	Art.-Nr. / Order no.
835	3	52	25	94	30	57	12000	300	0,003	M 54 x 1,5	03-835
845	4	60	28	106	35	63	10000	600	0,003	M 62 x 1,5	03-845
855	5	72	35	136	43	82	8000	1200	0,003	M 74 x 1,5	03-855
865	6	83	44	148	50	88	5000	2500	0,007	M 85 x 1,5	03-865

Serie 805 KOP Series 805 KOP



Mitlaufende Hochleistungs-Drehbankspitze, verlängert High performance revolving tailstock centre, extended

- wie Serie 805, aber mit verlängerter Spitze 30° / 60°
- as series 805, but with extended tip 30° / 60°

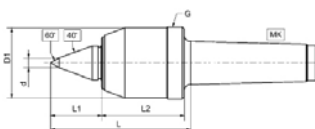

Typ / Type	MK / MT	D mm	D1 mm	L mm	L1 mm	L2 mm	d mm	Drehzahl / Speed max.	Werkst. / Work piece max. kg	Rundlaufgenauigkeit / Run-out max. mm	G	Art.-Nr. / Order no.
835 KOP	3	52	25	104	40	56	8	12000	200	0,003	M 54 x 1,5	03-835KOP
845 KOP	4	60	28	115	45	63	8	10000	400	0,003	M 62 x 1,5	03-845KOP
855 KOP	5	72	35	146	53	82	10	8000	800	0,003	M 74 x 1,5	03-855KOP
865 KOP	6	83	44	171	67	88	14	5000	1700	0,007	M 85 x 1,5	03-865KOP

Serie 1605 Series 1605



Mitlaufende Hochleistungs-Drehbankspitze Heavy-duty NC revolving tailstock centre

- mit Abdrückmutter
- Erhältlich in 2 Varianten:
Standard oder mit Hartmetalleinsatz
- with draw-off nut
- available in 2 versions:
standard or with carbide tip

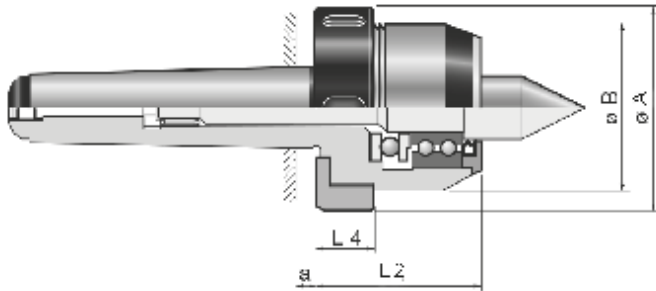

MK / MT	A mm	B mm	L1 mm	L2 mm	Drehzahl / Speed max.	Rundlaufgenauigkeit / Run-out max. mm	kg
3	69	55	49	22	7000	0,005	1,1
4	74	61	57	24	5500	0,005	1,9
5	92	80	65	24	4500	0,005	3,9
6	104	93	75	27	3200	0,008	8,8

Standard Standard

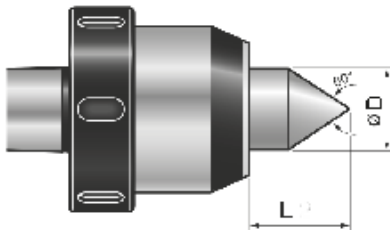

MK / MT	D mm	L mm	Art.-Nr. / Order no.
3	22	28	▶ 03-1603
4	29	40	▶ 03-1604
5	38	48	▶ 03-1605
6	42	55	▶ 03-1606

Mit Hartmetallspitze Carbide tip

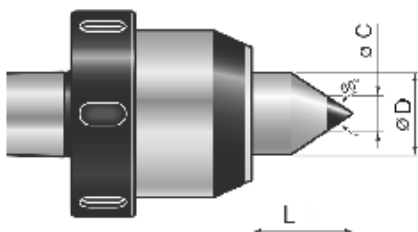

MK / MT	D mm	C mm	L mm	Art.-Nr. / Order no.
3	22	10	28	▶ 03-1603HM
4	29	12	40	▶ 03-1604HM
5	38	18	48	▶ 03-1605HM
6	42	20	55	▶ 03-1606HM

Serie 900 Series 900

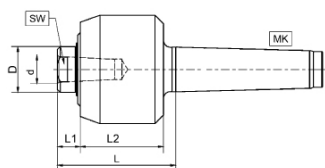

Mitlaufende Präzisions-Drehbankspitze für Wechseleinsätze Precision revolving tailstock centre for interchangeable inserts

- gleiche Konstruktion wie Reihe 800, jedoch für auswechselbare Einsätze (siehe Seiten 118 - 120)
- Lieferung ohne Einsätze
- komplette Sätze siehe Seite 120
- same construction as series 800, but for interchangeable inserts (see pages 118 - 120)
- delivered without inserts
- complete boxed sets see page 120

MK / MT	Typ / Type	D mm	D1 mm	d mm	L mm	L1 mm	L2 mm	SW	Drehzahl / Speed max.	Werkst. / Work piece max. kg	Rundlaufgenauigkeit / Run-out max. mm	Art.-Nr. / Order no.
2	923	45	20	12	59	10	43	17	5000	50	0,005	● 03-923
3	933	60	24	14	68	12	50	19	4300	200	0,005	● 03-933
4	943	76	32	18	79	13	58	27	3200	300	0,007	● 03-943
5	953	96	42	24	98	14	72	36	2600	800	0,01	● 03-953

Auswechselbare Einsätze für Serie 900 Interchangeable inserts for series 900

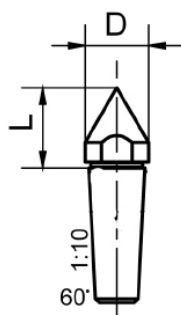

Kegelgröße / Taper ratio 1:10

Spitzkörner Pointed centre

Zu Typ / For type	D mm	L mm	Art.-Nr. / Order no.
923 / 935	14	20	● 03-923/1
933 / 945	16	21	● 03-933/1
943 / 955	22	27	● 03-943/1
953 / 965	28	34	● 03-953/1

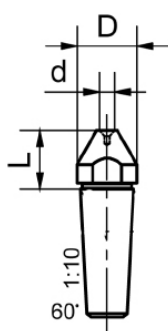

Kegelgröße / Taper ratio 1:10

Hohlkörner Hollow centre

Zu Typ / For type	D mm	d mm	L mm	Art.-Nr. / Order no.
923 / 935	14	4	15	● 03-923/2
933 / 945	16	4	17	● 03-933/2
943 / 955	22	5	21	● 03-943/2
953 / 965	28	6	27	● 03-953/2

Auswechselbare Einsätze für Serie 900

Interchangeable inserts for series 900

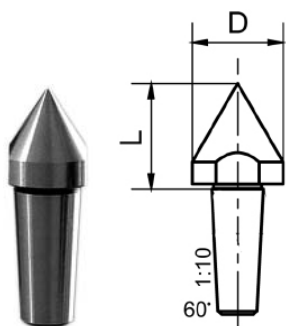

Kegelgröße / Taper ratio 1:10

Großer Spitzkörner

Large pointed centre

Zu Typ / For type	D mm	L mm	Art.-Nr. / Order no.
923 / 935	17	23	03-923/3
933 / 945	25	31	03-933/3
943 / 955	32	40	03-943/3
953 / 965	38	45	03-953/3

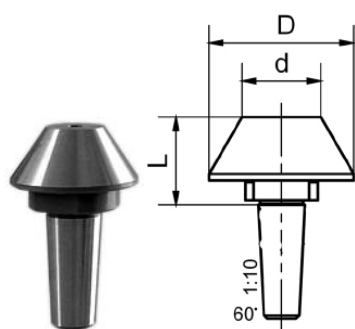

Kegelgröße / Taper ratio 1:10

Kegel

Taper

Zu Typ / For type	D mm	d mm	L mm	Art.-Nr. / Order no.
923 / 935	28	13	33	03-923/4
933 / 945	44	24	28	03-933/4
943 / 955	55	30	34	03-943/4
953 / 965	68	36	41	03-953/4

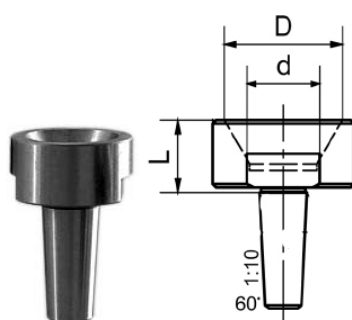

Kegelgröße / Taper ratio 1:10

Hohlkegel

Female taper

Zu Typ / For type	D mm	d mm	L mm	Art.-Nr. / Order no.
923 / 935	20	10	17	03-923/5
933 / 945	35	20	23	03-933/5
943 / 955	42	25	28	03-943/5
953 / 965	60	37	35	03-953/5

Auswechselbare Einsätze für Serie 900

Interchangeable inserts for series 900

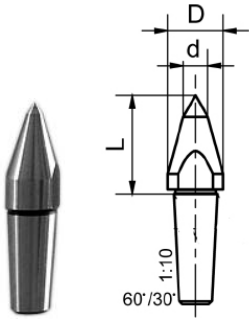

Kegegröße / Taper ratio 1:10

Kopierkörner

Copying centre

Zu Typ / For type	D mm	d mm	L mm	Art.-Nr. / Order no.
923 / 935	14	4	32	● 03-923/6
933 / 945	18	8	35	● 03-933/6
943 / 955	22	8	43	● 03-943/6
953 / 965	28	10	52	● 03-953/6



Satz im Kasten

Set in a box

Typ / Type	MK / MT	Art.-Nr. / Order no.
923	2	● 03-923K
933	3	● 03-933K
943	4	● 03-943K
953	5	● 03-953K

Serie 400

Series 400

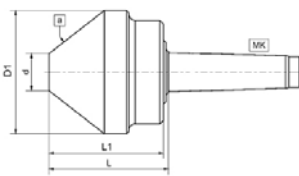

Mitlaufende Präzisions-Zentrierkegel

Precision revolving tube centre

- zur Bearbeitung von Rohren und anderen Hohlkörpern
 - ganzes Werkzeug gehärtet und fein geschliffen
 - stabile Konstruktion
 - wartungsfreie Dauerschmierung
 - abgedichtet
 - auch für Schleifarbeiten geeignet
- for machining of tubes and other hollow objects
 - completely hardened and fine-ground
 - time-tested and sturdy design
 - maintenance-free permanent lubrication
 - sealed
 - also suitable for grinding operations

Typ / Type	MK / MT	D1 mm	D mm	L mm	L1 mm	Winkel / Angle	Drehzahl / Speed max.	Werkst. / Work piece max. kg	Rundlauf- genauigkeit / Run-out max. mm	kg	Art.-Nr. / Order no.
421	2	60	20	73	66	60°	4000	200	0,005	1	● 03-421
431	3	80	30	86	78	60°	3500	450	0,005	2	● 03-431
432	3	100	30	100	92	75°	3000	400	0,005	4	● 03-432
441	4	100	30	101	92	75°	3000	650	0,005	4	● 03-441
442	4	125	50	91	82	75°	3000	650	0,007	5	● 03-442
451	5	125	50	92	82	75°	3000	1800	0,007	6	● 03-451
452	5	150	50	112	102	75°	2800	1900	0,007	9	● 03-452
461	6	150	50	112	102	75°	2800	2800	0,01	12	● 03-461
453	5	200	50	136	126	75°	1800	2000	0,01	15	● 03-453
462	6	200	50	136	126	75°	1800	2800	0,01	18	● 03-462

- Lagerstandard / in stock
- ▶ innerhalb weniger Tage / within a few days
- auf Anfrage / on request
- * auslaufende Größe / as stock lasts

Mitlaufende Drehbankspitzen BASIC

Revolving tailstock centres BASIC

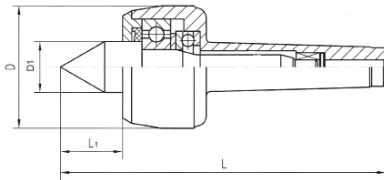
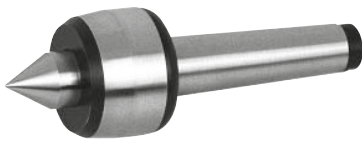

Mitlaufende Drehbankspitzen

Revolving tailstock centre

MK / MT	D mm	L mm	L1 mm	D1 mm	Winkel / Angle	Drehzahl / Speed max.	Werkst. / Work piece max. kg	Art.-Nr. / Order no.
1	36	114	17	15	60°	7000	100	13-MLK-01
2	45	129	24	20	60°	7000	200	13-MLK-02
3	60	160,5	31	25	60°	5000	500	13-MLK-03
4	70	205	41	32	60°	3800	800	13-MLK-04
5	90	258,5	50,5	40	60°	3000	2000	13-MLK-05
6	105	334	57,5	50	60°	2600	3500	13-MLK-06

Mitlaufende Drehbankspitzen, verlängert

Revolving tailstock centre, extended

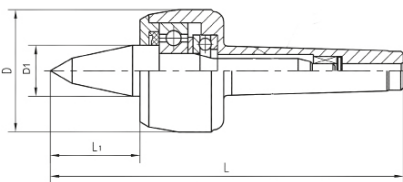

- mit verlängerter Spitze 30° / 60° - with extended tip 30° / 60°

MK / MT	D mm	L mm	L1 mm	D1 mm	Winkel / Angle	Drehzahl / Speed max.	Werkst. / Work piece max. kg	Art.-Nr. / Order no.
2	45	139	34	20	30°/60°	7000	140	13-MLK-02KOP
3	60	176,5	47	25	30°/60°	5000	400	13-MLK-03KOP
4	70	217	53	32	30°/60°	3800	500	13-MLK-04KOP
5	90	273	65	40	30°/60°	3000	1200	13-MLK-05KOP
6	105	354,5	78	50	30°/60°	2600	2500	13-MLK-06KOP

Mitlaufende Drehbankspitzen, schlanke Ausführung, 60°

Revolving tailstock centre, slim design, 60°

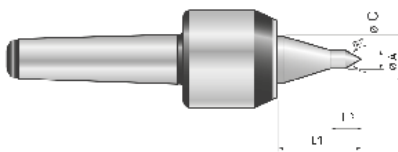

MK / MT	D1 mm	C mm	L1 mm	L2 mm	Winkel / Angle	Drehzahl / Speed max.	Werkst. / Work piece max. kg	Art.-Nr. / Order no.
1	16	6	25	9	60°	8500	140	03-SKP-1
2	22	8	32	11	60°	6000	400	03-SKP-2
3	22	10	42	15	60°	5000	500	03-SKP-3HS
4	29	12	51	16	60°	4000	1200	03-SKP-4HS
5	38	16	56	18	60°	3000	2500	03-SKP-5HS
6	42	18	78	20	60°	2500	2500	03-SKP-6HS

Mitlaufender Zentrierkegel BASIC

Revolving tube centres BASIC



Mitlaufender Zentrierkegel

Revolving tube centre

- gehärtet und geschliffen

- hardened and ground

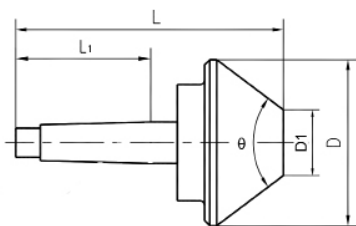

MK / MT	D mm	D1 mm	L mm	L1 mm	Winkel / Angle	Drehzahl / Speed max.	Werkst. / Work piece max. kg	Art.-Nr. / Order no.
2	60	20	132	64	60°	4000	200	13-MLZK-2/60
3	100	30	170	81	60°	3000	600	13-MLZK-3/100
4	160	40	232	102,5	60°	1900	800	13-MLZK-4/160
5	200	40	252	129,5	75°	1500	1600	13-MLZK-5/200
5	250	57	281	129,5	75°	1300	1800	13-MLZK-5/250
6	250	57	355	182	75°	1200	2000	13-MLZK-6/250

Feste Zentrierkegel BASIC

Fixed tube centre BASIC

Zentrierkegel, fest

Fixed tube centre

- gehärtet und geschliffen
- Rundlaufgenauigkeit: 0,003 mm
- *hardened and ground*
- *max. runout: 0,003 mm*

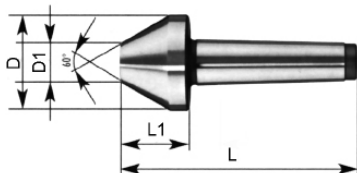

MK / MT	D mm	D1 mm	L1 mm	L mm	Art.-Nr. / Order no.
2	50	10	40	110	03-ZK-2-50
3	50	20	35	123	03-ZK-3-50
3	90	40	55	143	03-ZK-3-90
4	50	20	35	146	03-ZK-4-50
4	90	40	55	166	03-ZK-4-90
5	90	40	55	195	03-ZK-5-90
5	130	50	80	220	03-ZK-5-130

Zentrierkegel mit Abdrückgewinde, fest

Fixed tube centre with draw-off thread

- Lieferung ohne Abdrückmutter
- gehärtet und geschliffen
- Rundlaufgenauigkeit: 0,003 mm
- *supplied without draw-off nut*
- *hardened and ground*
- *max. runout: 0,003 mm*

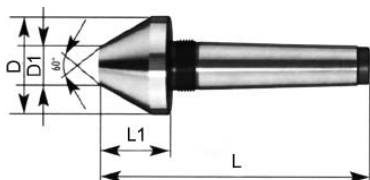

MK / MT	Gewinde / Thread mm	D mm	D1 mm	L1 mm	L mm	Art.-Nr. / Order no.
2	M22 x 1,5	50	10	40	122	03-ZKA-2-50
3	M27 x 1,5	50	20	35	136	03-ZKA-3-50
3	M27 x 1,5	90	40	55	156	03-ZKA-3-90
4	M36 x 1,5	50	20	35	162	03-ZKA-4-50
4	M36 x 1,5	90	40	55	182	03-ZKA-4-90
5	M48 x 1,5	90	40	55	211	03-ZKA-5-90
5	M48 x 1,5	130	50	80	236	03-ZKA-5-130

Abdrückmutter

Draw-off nut



MK / MT	Gewinde / Thread mm	Art.-Nr. / Order no.
1	M16 x 1,5	03-ADM-1
2	M22 x 1,5	03-ADM-2
3	M27 x 1,5	03-ADM-3
4	M36 x 1,5	03-ADM-4
5	M48 x 1,5	03-ADM-5
6	M68 x 1,5	03-ADM-6

Modulare Zentrierkegel und Futterflansche Modular tube centres and chuck adaptors

Grundkörper mitlaufend, Typ MGK Revolving base body, type MGK

- für Zentrierkegelköpfe Typ ZKK und Futterflansche Typ FFL
- for tube centres type ZKK and chuck adaptors type FFL

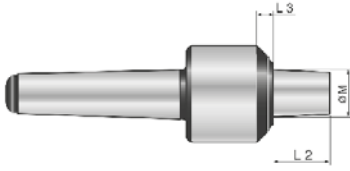

MK / MT	M mm	L2 mm	L3 mm	Art.-Nr. / Order no.
3	35	43	5	▶ 13-MGK-MK3
4	35	43	5	▶ 13-MGK-MK4
5	35	43	5	▶ 13-MGK-MK5
6	35	43	5	▶ 13-MGK-MK6
M80	35	44	6	▶ 13-MGK-M80

Grundkörper fest, Typ FGK Fixed base body, type FGK

- für Zentrierkegelköpfe Typ ZKK und Futterflansche Typ FFL
- for tube centres type ZKK and chuck adaptors type FFL

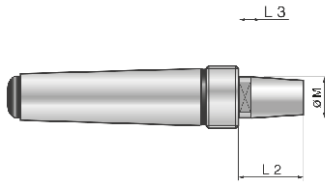

MK / MT	M mm	L2 mm	L3 mm	Art.-Nr. / Order no.
3	35	55	17	▶ 13-FGK-MK3
4	35	55	17	▶ 13-FGK-MK4
5	35	55	17	▶ 13-FGK-MK5
6	35	55	17	▶ 13-FGK-MK6

Zentrierkegelkopf, Typ ZKK Tube centre, type ZKK

- für die Bearbeitung von Rohren oder Hohlköpern von Ø 45 mm bis 600 mm
- for machining of pipes and hollow bodies from Ø 45 mm to Ø 600 mm
- für Grundkörper Typ MGK / FGK
- for base body type MGK / FGK

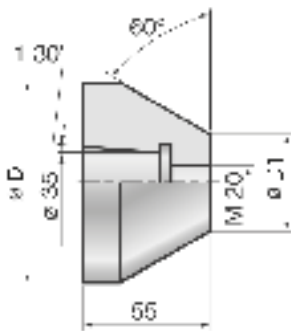

D1 mm	D mm	kg	Art.-Nr. / Order no.
45	98	1,6	▶ 13-ZKK-98
95	148	3,9	▶ 13-ZKK-148
145	198	7,1	▶ 13-ZKK-198
195	248	10,7	▶ 13-ZKK-248
245	298	15,0	▶ 13-ZKK-298
295	348	21,0	▶ 13-ZKK-348
345	398	20,0	▶ 13-ZKK-398
395	448	29,0	▶ 13-ZKK-448
445	498	34,0	▶ 13-ZKK-498
495	545	32,0	▶ 13-ZKK-545
545	600	36,0	▶ 13-ZKK-600

Abdrückschraube für Zentrierkegel Extraction screw for tailstock centre

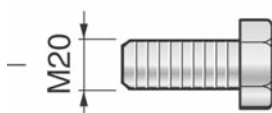

Gewinde / Thread	Art.-Nr. / Order no.
M20	▶ 13-ZKK-AS

- Lagerstandard / in stock
- ▶ innerhalb weniger Tage / within a few days
- auf Anfrage / on request
- * auslaufende Größe / as stock lasts



Modulare Zentrierkegel und Futterflansche

Modular tube centres and chuck adaptors

Futterflansch, Typ FFL Chuck adaptor, type FFL

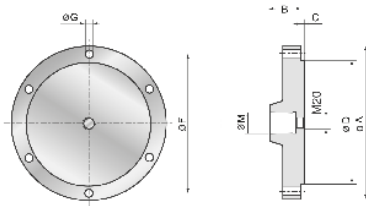

- zur Aufnahme von Drehfuttern nach DIN 6350
- für Grundkörper Typ MGK / FGK

- for mounting of chucks according to DIN 6350
- for base body type MGK / FGK

A mm	M mm	F mm	G mm	B mm	C mm	D mm	Art.-Nr. / Order no.
100	35	83	6,5	52,2	4,5	70	▶ 13-FFL-100
160	35	140	11	51,5	4,5	125	▶ 13-FFL-160
200	35	176	11	50,5	4,5	160	▶ 13-FFL-200
250	35	224	13	50,5	4,5	200	▶ 13-FFL-250

Typ DA, mit Druckanzeige und großem Federweg
Type DA, with pressure indication and long travel stroke

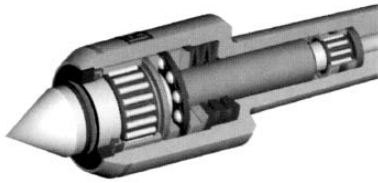

Anwendungsbereich:

Die Druckanzeige durch Farbringe ermöglicht eine schnelle Einstellung und Überwachung des optimalen Anstell-druckes. Bei fester Positionierung werden Längtoleranzen und unterschiedliche Zentrierbohrungen durch den Federweg kompensiert. Leichte Werkstücke können entsprechend fein gespannt werden.

Application:

A pressure indicator with different color bands permits rapid settings and monitoring of the optimum pressure. Length tolerances and different centre bores are compensated through a travel stroke at fixed positions. Thus light work pieces can be clamped very carefully.

Federkraft für allgemeines Drehen
Spring load for regular lathe

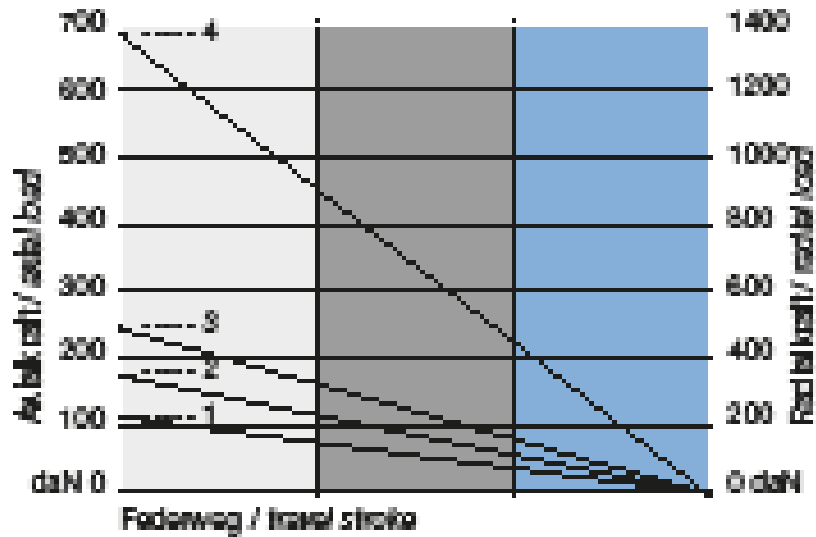

Ausführung / Model	Diagramm / Diagram
MK / MT 2	1
MK / MT 3	2
MK / MT 4	3
MK / MT 5	4
Zyl. / cyl. Ø20 x 40	1
Zyl. / cyl. Ø25 x 50	2
Zyl. / cyl. Ø1" x 2"	2
Zyl. / cyl. Ø32 x 63	3
VDI 20	1
VDI 30	2
VDI 40	3
VDI 50	4

Typ DA-N, normale Spitze, allgemeines Drehen
Type DA-N, regular tip, regular turning

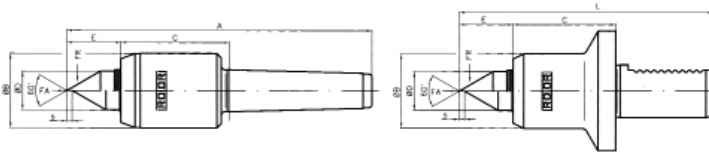

Ausführung / Model	FA daN	FR daN	L mm	B mm	C mm	D mm	E mm	s mm	Werkstück / Work piece max. kg	Drehzahl / Speed max.	Art.-Nr. / Order no.
MK / MT 2	11-110	24-240	136	34	53	14	19	2,7	190	7000	▶ 03-0241
MK / MT 3	20-200	40-420	173	42	62	22	31	3	440	5800	▶ 03-0341
MK / MT 4	23-230	50-500	209	53	72	28	33	4,3	900	4800	▶ 03-0441
MK / MT 5	80-800	150-1500	259	64	88	38	42	5,2	1850	4000	▶ 03-0541
Zyl. / cyl. Ø25 x 50	20-200	40-420	139	42	58	22	31	3	190	5800	▶ 03-2551
Zyl. / cyl. Ø1" x 2"	20-190	40-420	139	42	58	22	31	3	440	5800	▶ 03-0151
Zyl. / cyl. Ø32 x 63	23-230	50-500	165	53	68	28	33	4,3	900	4800	▶ 03-3251
VDI 20	11-110	24-240	108	34	48	14	19	2,7	190	7000	▶ 03-2061
VDI 30	20-200	40-420	144	42	58	22	31	3	440	5800	▶ 03-3061
VDI 40	23-230	50-500	165	53	68	28	33	4,3	900	4800	▶ 03-4061
VDI 50	80-800	150-1500	201	64	81	38	42	5,2	1850	4000	▶ 03-5061



Typ DA-V, verlängerte Spitze, allgemeines Drehen
Type DA-V, extended tip, regular turning

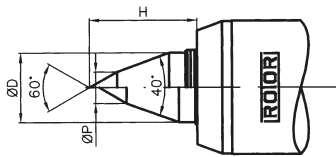

Ausführung / Model	D mm	H mm	P mm	Art.-Nr. / Order no.
MK / MT 2	15	22	8	03-0242
MK / MT 3	22	35	10	03-0342
MK / MT 4	28	41	14	03-0442
MK / MT 5	38	51	15	03-0542
Zyl. / cyl. Ø25 x 50	22	35	10	03-2552
Zyl. / cyl. Ø1" x 2"	22	35	10	03-0152
Zyl. / cyl. Ø32 x 63	28	41	14	03-3252
VDI 20	14	22	8	03-2062
VDI 30	22	35	10	03-3062
VDI 40	28	41	14	03-4062
VDI 50	38	51	15	03-5062

Typ DA-L, schlanke Spitze, allgemeines Drehen
Type DA-L, slim tip, regular turning

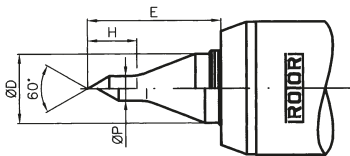

Ausführung / Model	D mm	E mm	H mm	P mm	Art.-Nr. / Order no.
MK / MT 2	14	28	12	5,8	03-0248
MK / MT 3	22	43	16	7,8	03-0348
MK / MT 4	28	51	19	9,8	03-0448
MK / MT 5	38	62	22	11,8	03-0548
Zyl. / cyl. Ø25 x 50	22	43	16	7,8	03-2558
Zyl. / cyl. Ø1" x 2"	22	43	16	7,8	03-0158
Zyl. / cyl. Ø32 x 63	28	51	19	9,8	03-3258
VDI 20	14	28	12	5,8	03-2068
VDI 30	22	43	16	7,8	03-3068
VDI 40	28	51	19	9,8	03-4068
VDI 50	38	62	22	11,8	03-5068

Typ E-B, Vollkegel 60°
Type E-B, pipe nose 60°

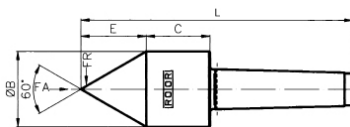

Ausf. / Model	MK / MT	L mm	B mm	C mm	E mm	Werkst. / Work pc. max. kg	FR max. daN	FA max. daN	Rundlaufabw. / Max. runout	Drehzahl / Speed max.	Art.-Nr. / Order no.
ST	2	132	38	30	33	180	90	90	0,002	13500	03-2110
SU	2	143	45	35	39	260	130	115	0,002	11000	03-2210
ST	3	160	45	35	39	260	130	115	0,002	11000	03-3110
SU	3	184	55	50	48	440	220	260	0,002	8500	03-3210
ST	4	206	55	50	48	440	220	260	0,002	8500	03-4110
SU	4	255	70	57	61	670	335	440	0,002	6700	03-4210
ST	5	253	70	57	61	670	335	440	0,002	6700	03-5110
SU	5	275	80	70	69	950	475	925	0,004	5300	03-5210
ST	6	329	80	70	69	950	475	925	0,004	5300	03-6110

Feste Zentrierspitzen Serie 500

Fixed centres series 500

Feststehende Präzisions-Zentrierspitzen nach DIN 806+807

Fixed centres according to DIN 806+807

- ganz gehärtet und geschliffen
- completely hardened and ground

Typ 501 DIN 806 WS

Type 501 DIN 806 WS

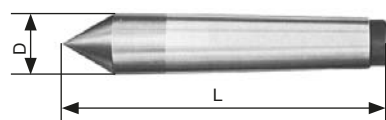

Standard
Standard

Typ / Type	MK / MT	D mm	L mm	Winkel / Angle	Art.-Nr. / Order no.
511	1	12,2	80	60°	● 03-511
521	2	18	100	60°	● 03-521
531	3	24,1	125	60°	● 03-531
541	4	31,6	160	60°	● 03-541
551	5	44,7	200	60°	● 03-551
561	6	63,8	270	60°	● 03-561

Typ 503 DIN 806 E

Type 503 DIN 806 E

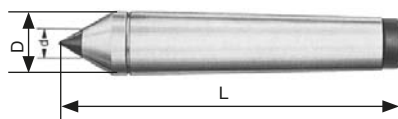

Hartmetalleinsatz
Full carbide tip

Typ / Type	MK / MT	D mm	L mm	Winkel / Angle	d mm	Art.-Nr. / Order no.
513	1	12,2	80	60°	7	● 03-513
523	2	18	100	60°	7	● 03-523
533	3	24,1	125	60°	11	● 03-533
543	4	31,6	160	60°	14	● 03-543
553	5	44,7	200	60°	18	● 03-553
563	6	63,8	270	60°	18	● 03-563

Typ 504 DIN 806 HE

Type 504 DIN 806 HE

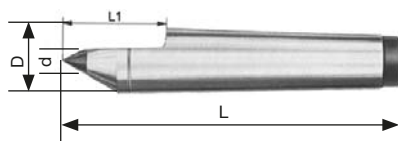

Hartmetalleinsatz mit halber Spitze
Half carbide tip

Typ / Type	MK / MT	D mm	L mm	Winkel / Angle	d mm	L1 mm	Art.-Nr. / Order no.
514	1	12,2	80	60°	7	22	● 03-514
524	2	18	100	60°	7	30	● 03-524
534	3	24,1	125	60°	11	38	● 03-534
544	4	31,6	160	60°	14	50	● 03-544
554	5	44,7	200	60°	18	63	● 03-554
564	6	63,8	270	60°	18	79	* 03-564

Typ 504 DIN 806 HE - verlängert

Type 504 DIN 806 HE - extended

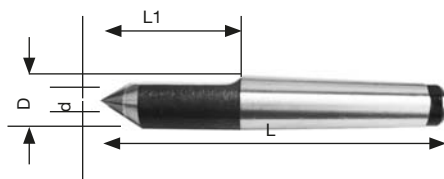

Hartmetalleinsatz mit verlängerter halber Spitze
Extended half carbide tip

Typ / Type	MK / MT	D mm	L mm	Winkel / Angle	d mm	L1 mm	Art.-Nr. / Order no.
524VL	2	18	135	60°	11	65	● 03-524VL
534VL	3	24,1	150	60°	14	63	● 03-534VL
544VL	4	31,6	180	60°	18	70	● 03-544VL

- Lagerstandard / in stock
- ▶ innerhalb weniger Tage / within a few days
- auf Anfrage / on request
- * auslaufende Größe / as stock lasts

Feste Zentrierspitzen Serie 500

Fixed centres series 500

Typ 505 DIN 807 WS

Type 505 DIN 807 WS

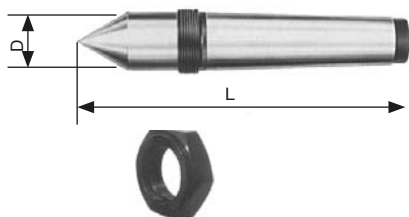

Mit Abdrückmutter
With draw-off nut

Typ / Type	MK / MT	D mm	L mm	Winkel / Angle	G mm	Art.-Nr. / Order no.
525	2	18	100	60°	M22x1,5	● 03-525
535	3	24,1	125	60°	M27x1,5	● 03-535
545	4	31,6	160	60°	M36x1,5	● 03-545
555	5	44,7	200	60°	M48x1,5	● 03-555
565	6	63,8	270	60°	M68x1,5	● 03-565

Typ 506 DIN 807 E

Type 506 DIN 807 E



Hartmetalleinsatz mit Abdrückgewinde
Full carbide tip with thread

Typ / Type	MK / MT	D mm	L mm	Winkel / Angle	d mm	G mm	Art.-Nr. / Order no.
526	2	18	112	60°	7	M22x1,5	● 03-526
536	3	24,1	137	60°	11	M27x1,5	● 03-536
546	4	31,6	175	60°	14	M36x1,5	● 03-546
556	5	44,7	217	60°	18	M48x1,5	● 03-556
566	6	63,8	290	60°	18	M68x1,5	● 03-566

Typ 507 DIN 807 HE

Type 507 DIN 807 HE

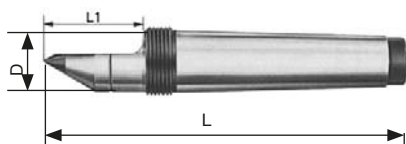

Hartmetalleinsatz, mit halber Spitze
mit Abdrückgewinde
Half carbide tip with thread

Typ / Type	MK / MT	D mm	L mm	Winkel / Angle	d mm	L1 mm	G mm	Art.-Nr. / Order no.
527	2	18	112	60°	7	30	M22x1,5	✘ 03-527
537	3	24,1	137	60°	11	38	M27x1,5	✘ 03-537
547	4	31,6	175	60°	14	50	M36x1,5	✘ 03-547
557	5	44,7	217	60°	18	63	M48x1,5	✘ 03-557
567	6	63,8	290	60°	18	79	M68x1,5	✘ 03-567

Typ 508 DIN 807 WS

Type 508 DIN 807 WS

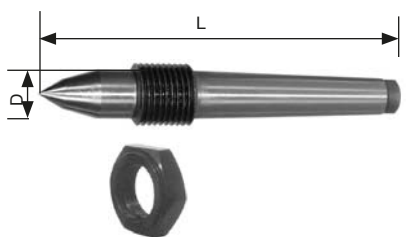

Verlängerte Spitze mit Abdrückmutter
Extended tip with draw-off nut

Typ / Type	MK / MT	D mm	L mm	Winkel / Angle	G mm	Art.-Nr. / Order no.
518	1	12,2	80	30°/60°	M16x1,5	✘ 03-518
528	2	18	118	30°/60°	M22x1,5	● 03-528
538	3	24,1	148	30°/60°	M27x1,5	● 03-538
548	4	31,6	186,5	30°/60°	M36x1,5	● 03-548
558	5	44,7	242	30°/60°	M48x1,5	● 03-558
568	6	63,8	330	30°/60°	M68x1,5	✘ 03-568

Passende Abdrückmuttern siehe Seite 123
Suitable draw-off nuts see page 123

Stirnmitnehmer, mechanisch

Mechanical face drivers

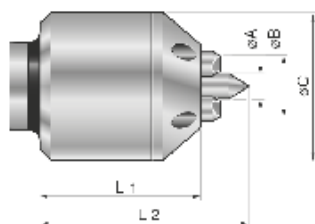

Lieferumfang:
Stirnmitnehmer, 1 Satz Mitnehmerbolzen S1,
1 Stück Zentrierspitze S4

Scope of supply:
Mechanical face driver, 1 set inserts S1,
1 piece centre S4

Typ A (19,3-32 mm)

Type A (19,3-32 mm)

Art.-Nr. /
Order no.

03-EA-S?

Beispiel / Ordering example
= 03-EA-S1

MK / MT	Ø Min. mm	Ø Max. mm	Ø A mm	Ø B mm	Ø C mm	L1 mm	L2 mm	kg	Art.-Nr. / Order no.
3	19,3	32	8	20	48	52	67	0,9	03-SMN-3/25
4	19,3	32	8	20	48	52	67	1,2	03-SMN-4/25



Typ B (30-47 mm)

Type B (30-47 mm)

Art.-Nr. /
Order no.

03-EB-S?

Beispiel / Ordering example
= 03-EB-S1

MK / MT	Ø Min. mm	Ø Max. mm	Ø A mm	Ø B mm	Ø C mm	L1 mm	L2 mm	kg	Art.-Nr. / Order no.
3	30	47	12	30	62	64	86	1,5	03-SMN-3/47
4	30	47	12	30	62	64	86	2,7	03-SMN-4/47
5	30	47	12	30	62	64	86	3,9	03-SMN-5/47



Typ C (40-70 mm)

Type C (40-70 mm)

Art.-Nr. /
Order no.

03-EC-S?

Beispiel / Ordering example
= 03-EC-S1

MK / MT	Ø Min. mm	Ø Max. mm	Ø A mm	Ø B mm	Ø C mm	L1 mm	L2 mm	kg	Art.-Nr. / Order no.
4	40	70	18	41	87	95	125	4,3	03-SMN-4/70
5	40	70	18	41	87	95	125	5,3	03-SMN-5/70
6	40	70	18	41	87	95	125	7,8	03-SMN-6/70

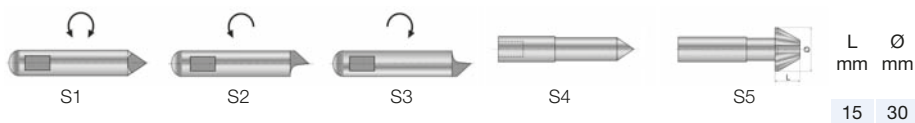

Typ D (57-90 mm)

Type D (57-90 mm)

Art.-Nr. /
Order no.

03-ED-S?

Beispiel / Ordering example
= 03-ED-S1

MK / MT	Ø Min. mm	Ø Max. mm	Ø A mm	Ø B mm	Ø C mm	L1 mm	L2 mm	kg	Art.-Nr. / Order no.
4	57	90	23	57	109	100	140	7,0	03-SMN-4/90
5	57	90	23	57	109	100	140	8,2	03-SMN-5/90
6	57	90	23	57	109	100	140	9,5	03-SMN-6/90

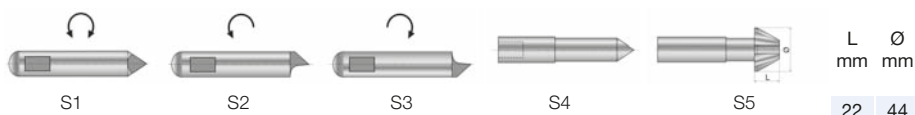

Kegelhülsen Conic bushes

Kegelhülsen, zylindrisch mit Innenkegel (MK) Conic bushes, cylindrical with internal taper (MT)

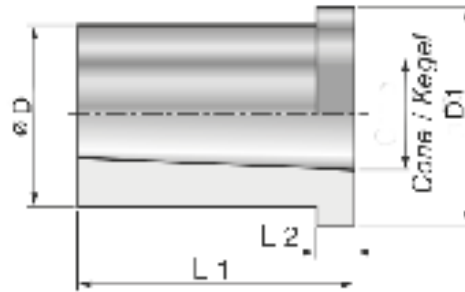
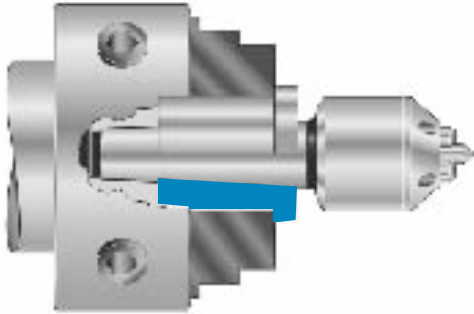

MK / MT	L1 mm	L2 mm	Ø D mm	D1 mm	kg	Art.-Nr. / Order no.
3	65	8	35	44	0,3	▶ 03-KH-3
4	70	8	42	49	0,45	▶ 03-KH-4
5	80	10	54	59	0,6	▶ 03-KH-5
6	85	10	75	84	0,75	▶ 03-KH-6

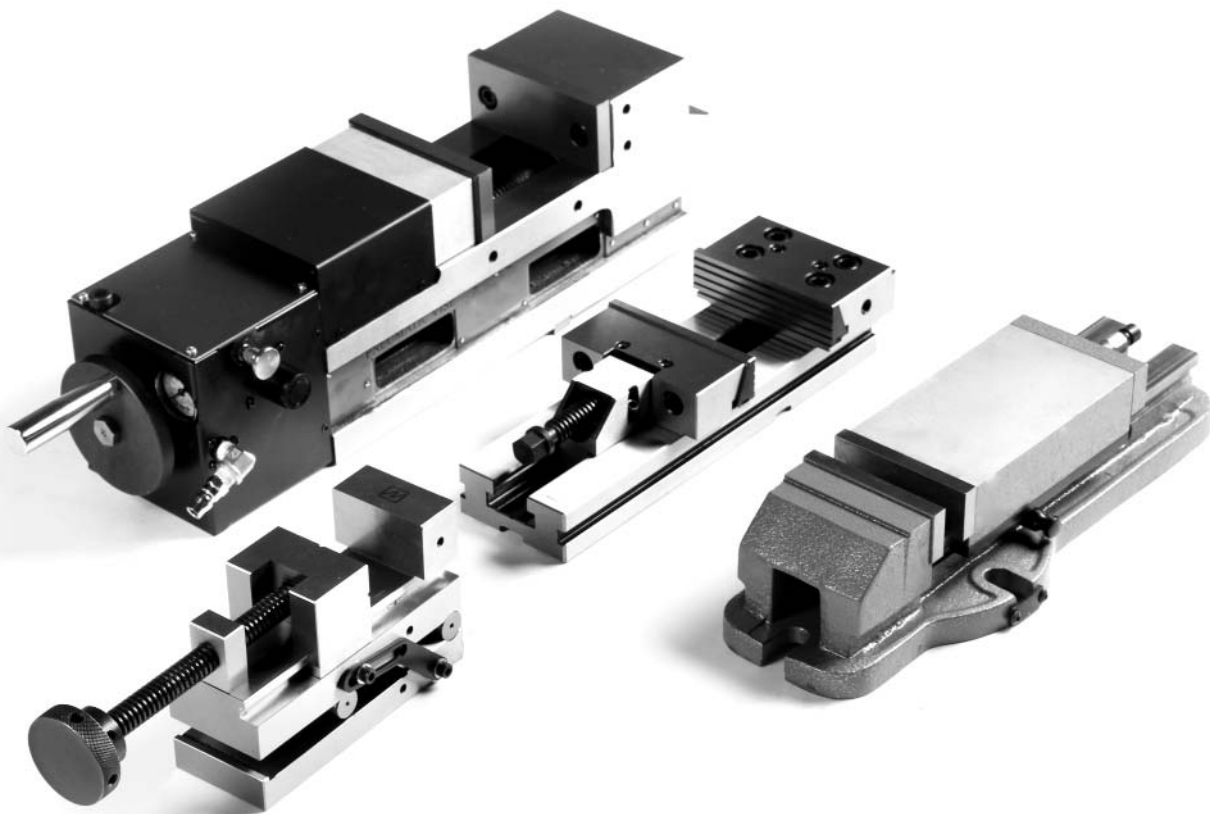

■ Inhalt:

- | Maschinenschraubstöcke Typ CMC / SVC
- | Doppelspanner
- | Doppel-Zentrischspanner
- | Pneumatikspanner
- | Mehrfach-Spanneinrichtung
- | NC-Spanner
- | Mechanische und hydraulische Maschinenschraubstöcke
- | Fräsmaschinenschraubstöcke
- | 3-Achsen-Schraubstock
- | Bohrmaschinenschraubstöcke
- | Werkbankschraubstöcke
- | Zentrischspanner
- | 5-Achsen-Zentrischspanner
- | Schleifschraubstöcke
- | Sinus-Schraubstöcke
- | Erodierschraubstöcke
- | Präzisions-Schraubstöcke **CARMINATI MORSE**
- | Universal-Werkstückanschläge
- | Universal Aufsatzprismenbacken

■ Content:

- | Precision machine vices type CMC / SVC
- | Double vices
- | Double-self-centering vice
- | Pneumatic vices
- | Multiflex vices
- | NC-vices
- | Mechanical and hydraulic machine vices
- | Milling machine vices
- | 3-axes machine vices
- | Drilling machine vices
- | Table vices
- | Self-centering vices
- | 5-axes self-centering vices
- | Tool maker vices
- | Since vices
- | Erosion vices
- | Precision vices **CARMINATI MORSE**
- | Stop-dogs
- | Universal prism jaws



Maschinenschraubstöcke Typ CMC / SVC

Precision machine vices type CMC / SVC

Präzisions-Maschinenschraubstock Typ CMC

Precision machine vice type CMC

- Führungsflächen gehärtet
 - mit Niederzugeffekt
 - modulares System
 - Parallelität < 0,005 / 100 mm
 - Rechtwinkligkeit < 0,02 / 50 mm
 - Wiederholgenauigkeit < 0,02 mm
 - feste Backe um 180° drehbar, Rückseite mit Spannstufe
 - auch als Doppelspanner erhältlich, siehe Seite 138 (Typ DZM)
- hardened slideways
 - with pull-down mechanism
 - modular system
 - parallelism < 0,005 / 100 mm
 - perpendicularity < 0,02 / 50 mm
 - repeatability < 0,02 mm
 - fixed jaw rotatable by 180°, reverse with step
 - also available as double-self-centering-vice, see page 138 (Typ DZM)

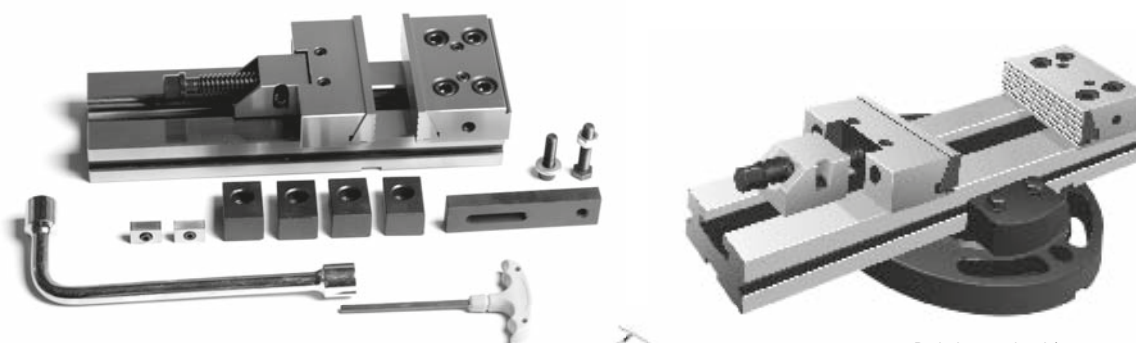

Drehplatte optional / Swivel plate optional

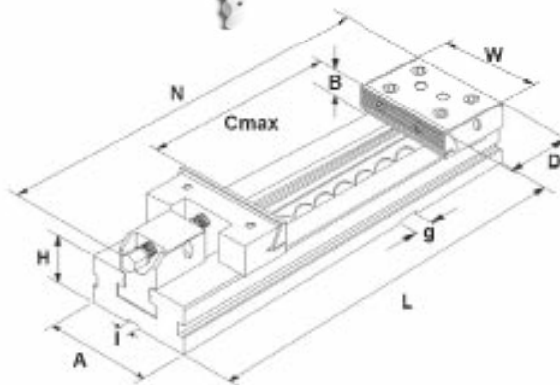

W mm	Cmax mm	L mm	N mm	A mm	D mm	H mm	g mm	B mm	Max. Anz. moment / Max. torque Nm	Max. Spann- kraft / Clamping force daN	kg	Art.-Nr. / Order no.
100	100	270	320	75	77,9	35	16	30	30	3000	7	ZE-CMC-100/100
125	150	345	410	95	77,9	40	16	40	40	3000	13	ZE-CMC-125/150
150	200	420	500	125	89,4	50	16	50	60	5000	26	ZE-CMC-150/200
150	300	520	600	125	89,4	50	16	50	60	5000	29	ZE-CMC-150/300
175	200	455	530	145	96,8	58	16	60	60	6000	37	ZE-CMC-175/200
175	300	555	630	145	96,8	58	16	60	60	6000	42	ZE-CMC-175/300
175	400	655	730	145	96,8	58	16	60	60	6000	47	ZE-CMC-175/400
200	200	495	580	170	113	70	16	65	80	10000	64	ZE-CMC-200/200
200	300	595	680	170	113	70	16	65	80	10000	69	ZE-CMC-200/300
200	400	695	780	170	113	70	16	65	80	10000	74	ZE-CMC-200/400
200	500	795	880	170	113	70	16	65	80	10000	84	ZE-CMC-200/500
300	300	635	730	195	120	78	16	80	80	10000	105	ZE-CMC-300/300
300	400	735	830	195	120	78	16	80	80	10000	115	ZE-CMC-300/400

Inkl. Spannpratzen, Passsteine, Schlüssel, Handkurbel und Werkstückanschlag
Incl. brackets, T-nuts, wrench, crank and work piece stop

Maschinenschraubstöcke Typ CMC / SVC

Precision machine vices type CMC / SVC

Präzisions-Maschinenschraubstock mit Schnellverstellung Typ SVC

Precision machine vice with quick adjustment type SVC

- wie Typ CMC, jedoch mit Schnellverstellung
- as type CMC, but with quick adjustment

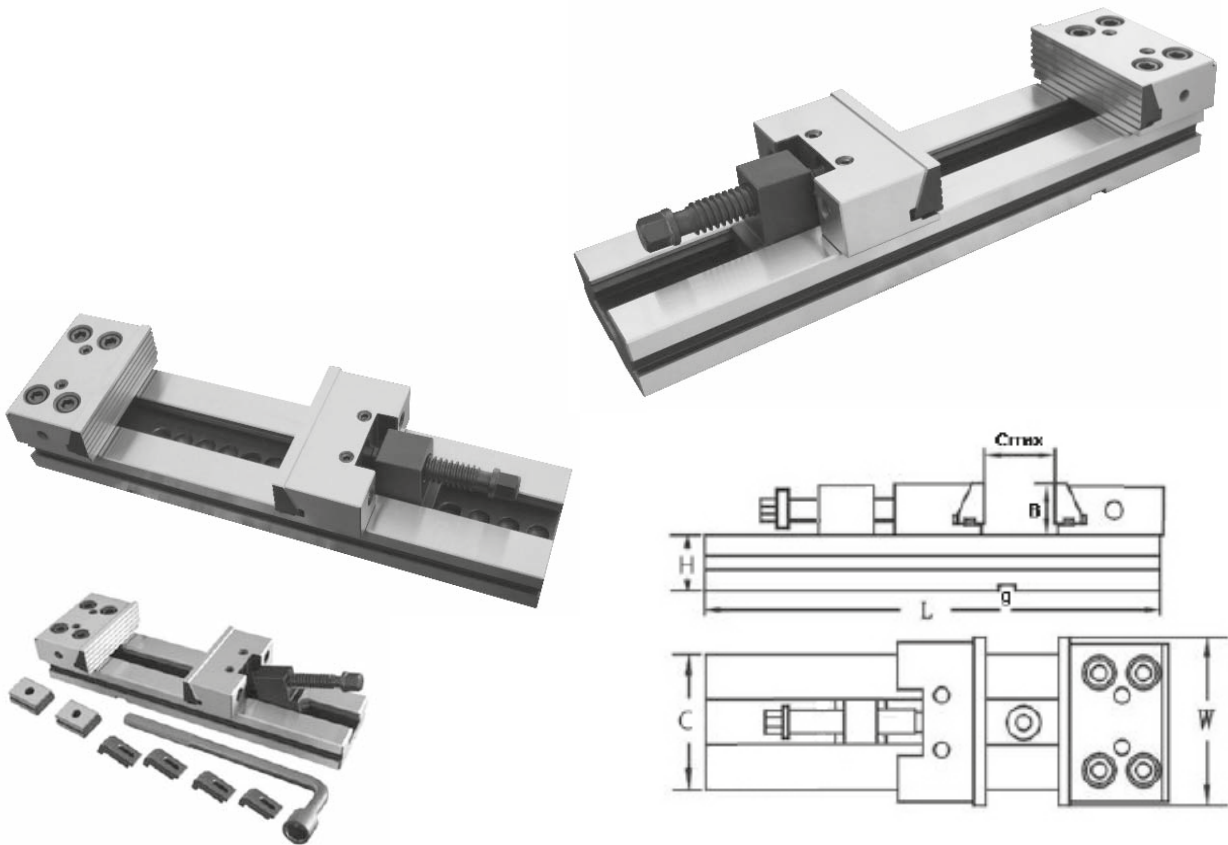

W mm	C _{max} mm	L mm	A mm	H mm	B mm	g mm	Max. Anz. moment / Max. torque Nm	Max. Spann- kraft / Clamping force daN	kg	Art.-Nr. / Order no.
100	100	270	75	35	30	16	30	3000	7	● ZE-SVC-100/100
125	150	345	95	40	40	16	40	3000	13	● ZE-SVC-125/150
150	200	420	125	50	50	16	60	5000	26	● ZE-SVC-150/200
150	300	520	125	50	50	16	60	5000	29	● ZE-SVC-150/300
175	300	555	145	58	60	16	60	6000	42	● ZE-SVC-175/300
200	200	495	170	70	65	16	80	10000	64	● ZE-SVC-200/200
200	300	595	170	70	65	16	80	10000	69	● ZE-SVC-200/300
200	400	695	170	70	65	16	80	10000	74	● ZE-SVC-200/400

Inkl. Spannpratzen, Passsteine, Schlüssel, Handkurbel und Werkstückanschlag
Incl. brackets, T-nuts, wrench, crank and work piece stop

Geteilte Schraubstöcke Typ CMC

Modular vices type CMC

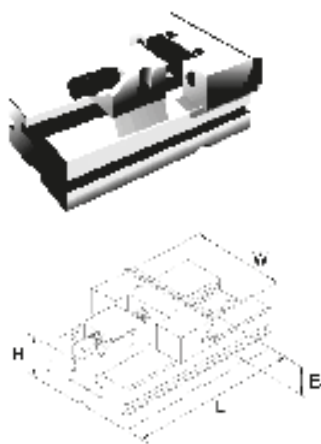

Bewegliches Element Typ CMC

Movable jaw section type CMC

- speziell zum Spannen übergroßer Werkstücke
- vielseitige Spannmöglichkeiten
- for clamping oversized work pieces
- various clamping possibilities

W mm	B mm	L mm	H mm	kg	Art.-Nr. / Order no.
100	30	140	35	4	<input checked="" type="checkbox"/> ZE-GS-B100
125	40	160	40	6	<input checked="" type="checkbox"/> ZE-GS-B125
150	50	230	50	14	<input checked="" type="checkbox"/> ZE-GS-B150
175	60	240	58	21	<input checked="" type="checkbox"/> ZE-GS-B175
200	65	300	70	35	<input checked="" type="checkbox"/> ZE-GS-B200

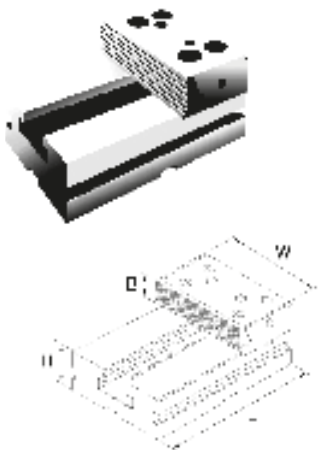

Festes Element Typ CMC

Fixed jaw section type CMC

W mm	B mm	L mm	H mm	kg	Art.-Nr. / Order no.
100	30	140	35	4	<input checked="" type="checkbox"/> ZE-GS-F100
125	40	160	40	6	<input checked="" type="checkbox"/> ZE-GS-F125
150	50	230	50	13	<input checked="" type="checkbox"/> ZE-GS-F150
175	60	240	58	18	<input checked="" type="checkbox"/> ZE-GS-F175
200	65	300	70	30	<input checked="" type="checkbox"/> ZE-GS-F200

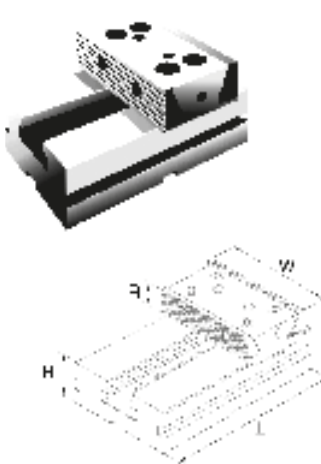

Festes Element doppelt Typ CMC

Double fixed jaw section type CMC

- mit beidseitiger Spannmöglichkeit
- with double-sided clamping possibility

W mm	B mm	L mm	H mm	kg	Art.-Nr. / Order no.
100	30	140	35	4	<input type="checkbox"/> ZE-GS-D100
125	40	160	40	6	<input type="checkbox"/> ZE-GS-D125
150	50	230	50	13	<input checked="" type="checkbox"/> ZE-GS-D150
175	60	240	58	19	<input checked="" type="checkbox"/> ZE-GS-D175
200	65	300	70	30	<input checked="" type="checkbox"/> ZE-GS-D200

Zubehör für Typ CMC / SVC Accessories for type CMC / SVC

Drehplatte Swivel plate



passend zu / suitable for	Art.-Nr. / Order no.
100	<input checked="" type="checkbox"/> ZE-CMC-100D
125	<input checked="" type="checkbox"/> ZE-CMC-125D
150	<input checked="" type="checkbox"/> ZE-CMC-150D
175	<input checked="" type="checkbox"/> ZE-CMC-175D
200	<input checked="" type="checkbox"/> ZE-CMC-200D
300	<input type="checkbox"/> ZE-CMC-300D

Preis pro Stück / Price per piece

Rillenbacke Grooved jaw

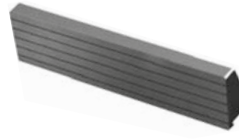

passend zu / suitable for	Art.-Nr. / Order no.
100	<input checked="" type="checkbox"/> ZE-CMC-100RB
125	<input checked="" type="checkbox"/> ZE-CMC-125RB
150	<input checked="" type="checkbox"/> ZE-CMC-150RB
175	<input checked="" type="checkbox"/> ZE-CMC-175RB
200	<input checked="" type="checkbox"/> ZE-CMC-200RB
300	<input type="checkbox"/> ZE-CMC-300RB

Preis pro Stück / Price per piece

Glatte Backe Plain jaw



passend zu / suitable for	Art.-Nr. / Order no.
100	<input checked="" type="checkbox"/> ZE-CMC-100GB
125	<input checked="" type="checkbox"/> ZE-CMC-125GB
150	<input checked="" type="checkbox"/> ZE-CMC-150GB
175	<input checked="" type="checkbox"/> ZE-CMC-175GB
200	<input checked="" type="checkbox"/> ZE-CMC-200GB
300	<input type="checkbox"/> ZE-CMC-300GB

Preis pro Stück / Price per piece

Weiche Backe Soft machinable jaw



passend zu / suitable for	Art.-Nr. / Order no.
100	<input checked="" type="checkbox"/> ZE-CMC-100WB
125	<input checked="" type="checkbox"/> ZE-CMC-125WB
150	<input checked="" type="checkbox"/> ZE-CMC-150WB
175	<input checked="" type="checkbox"/> ZE-CMC-175WB
200	<input checked="" type="checkbox"/> ZE-CMC-200WB
300	<input type="checkbox"/> ZE-CMC-300WB

Preis pro Stück / Price per piece

Spannbacke überhoch Extra-high jaw



passend zu / suitable for	Art.-Nr. / Order no.
100	<input type="checkbox"/> ZE-CMC-100GH
125	<input checked="" type="checkbox"/> ZE-CMC-125GH
150	<input checked="" type="checkbox"/> ZE-CMC-150GH
175	<input checked="" type="checkbox"/> ZE-CMC-175GH
200	<input checked="" type="checkbox"/> ZE-CMC-200GH

Preis pro Stück / Price per piece

Prismenbacke Prism jaw



passend zu / suitable for	Art.-Nr. / Order no.
100	<input checked="" type="checkbox"/> ZE-CMC-100PB
125	<input checked="" type="checkbox"/> ZE-CMC-125PB
150	<input checked="" type="checkbox"/> ZE-CMC-150PB
175	<input checked="" type="checkbox"/> ZE-CMC-175PB
200	<input checked="" type="checkbox"/> ZE-CMC-200PB

Preis pro Stück / Price per piece

Niederzugbacke überhoch Extra-high pull down jaw

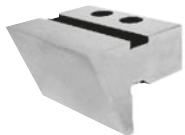

passend zu / suitable for	Art.-Nr. / Order no.
125	<input checked="" type="checkbox"/> ZE-CMC-125NH
150	<input checked="" type="checkbox"/> ZE-CMC-150NH
175	<input checked="" type="checkbox"/> ZE-CMC-175NH
200	<input checked="" type="checkbox"/> ZE-CMC-200NH

Preis pro Stück / Price per piece

Koordinaten-Prismenbacke Prismatic stack type jaw



passend zu / suitable for	Art.-Nr. / Order no.
100	<input type="checkbox"/> ZE-CMC-100KB
125	<input checked="" type="checkbox"/> ZE-CMC-125KB
150	<input checked="" type="checkbox"/> ZE-CMC-150KB
175	<input checked="" type="checkbox"/> ZE-CMC-175KB
200	<input checked="" type="checkbox"/> ZE-CMC-200KB

Preis pro Stück / Price per piece



Doppelspanner Double vices

Doppelspanner Typ TLD Double vices type TLD

- mechanisch
 - zentrisches Spannen von 2 Werkstücken gleicher oder unterschiedlicher Größe
 - Führungsflächen gehärtet
 - mit Niederzugeffekt
 - 6 verschiedene Spannmöglichkeiten
 - einfahrbare Spindel (nur Typ TLD-150), komplett abgedeckt
- mechanically
 - self centering for 2 work pieces of same or different size hardened slideways
 - with pull-down mechanism
 - 6 clamping options
 - retractable spindle (only type TLD-150), completely covered

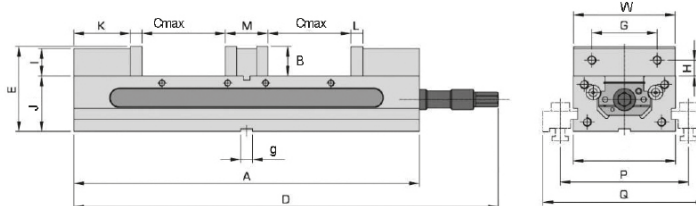
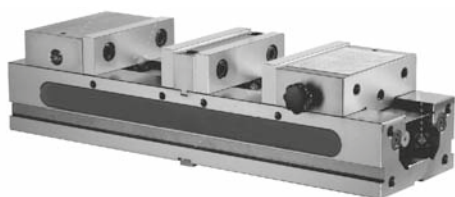

Typ / Type	A	J	O	D	E	W	G	H	I	B	K	L	M	g	Cmax	P	Q	Max. Spannkraft / Clamping force daN	kg	Art.-Nr. / Order no.
100	405	63,5	104	459	101,5	102	63,5	17,5	33	38	69	15	55	18	90	143	195	2600	20	ZE-TLD-100
150	520	82,5	154	536	127	152	98,4	23,8	41,5	44,5	86,5	18	66	18	125	193	245	3000	52	ZE-TLD-150

Passende Nutensteine lieferbar auf Anfrage
Suitable t-nuts available upon request

Doppel-Zentrischspanner, Typ DZM Double-self-centering vice, type DZM

- wie Typ CMC (Seite 134), jedoch zum Spannen von 2 Werkstücken
- as type CMC (page 134), but for clamping 2 workpieces

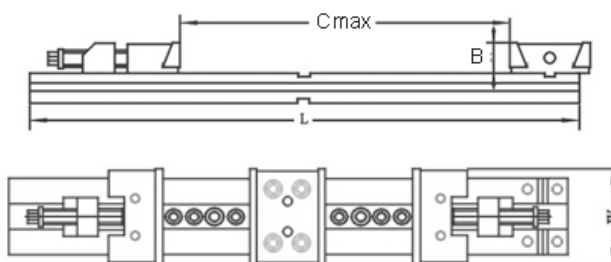

W	Cmax	L	B	kg	Art.-Nr. / Order no.
175	120	666	60	63	* ZE-DZM-175/120
175	170	766	60	67	* ZE-DZM-175/170
200	150	805	65	100	* ZE-DZM-200/150
200	206	905	65	108	* ZE-DZM-200/200

Inkl. Spannpratzen, Passsteine, Schlüssel, Handkurbel und Werkstückanschlag
Incl. brackets, T-nuts, wrench, crank and work piece stop

Passende Ersatzbacken für den Typ ZE-DZM- siehe Seite 137
Suitable jaws for type ZE-DZM- see page 137



Pneumatikspanner Pneumatic vices

Typ PSP Type PSP

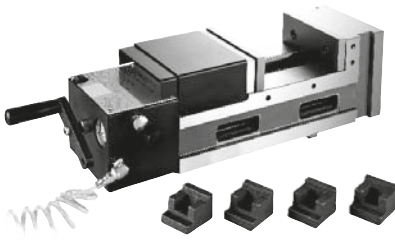

- Betätigung durch Pressluft
- besonders geeignet für Serienfertigung auf Maschinenzentren, Fräs- und Bohrmaschinen und Sondermaschinen
- mit Niederzugeffekt
- Taktzeit nur 1,5 s
- Hub bis 8 mm
- einstellbar von 0-4000 kg/cm²

- operated by compressed air
- suitable for mass production and for machine centers, milling, drilling and special-purpose machines
- with pull-down mechanism
- cycle speed 1,5 s
- clamping stroke up to 8 mm
- adjustable from 0-4000 kg/cm²

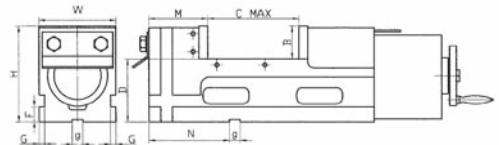
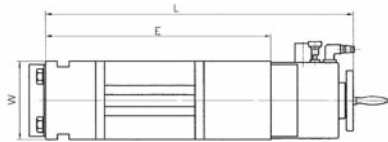

Typ / Type	W mm	B mm	Cmax mm	D mm	E mm	L mm	F mm	G mm	H mm	M mm	g mm	N mm	Max. Spannkraft / Clamping force daN	kg	Art.-Nr. / Order no.
130/150	130	55	150	105	380	520	25	9	160	100	18	136	6000	41	ZE-PSP-130/150
160/160	160	58	160	105	400	540	25	9	163	100	18	136	6000	50	ZE-PSP-160/160
160/250	160	58	250	105	490	630	25	9	163	100	18	136	6000	57	ZE-PSP-160/250
200/200	200	63	200	110	470	610	25	12	173	108	18	171	9000	77	ZE-PSP-200/200
200/300	200	63	300	110	570	710	25	12	173	108	18	171	9000	86	ZE-PSP-200/300

Pneumatischer Doppelspanner Typ DPSP Pneumatic double vice type DPSP

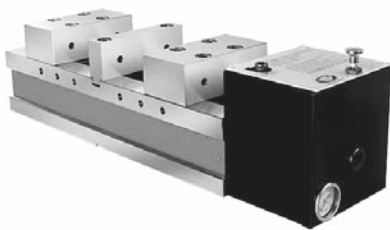

- Betätigung durch Pressluft
- mit Niederzugeffekt
- mit 2 Spannstellen
- Taktzeit nur 1,5 s
- Hub bis 8 mm
- Werkstücke unterschiedlicher Größe (bis 5 mm) spannbar
- einstellbar von 0-4000 kg/cm²

- operated by compressed air
- with pull-down mechanism
- for 2 work pieces
- cycle speed 1,5 s
- clamping stroke up to 8 mm
- work pieces of different sizes (up to 5 mm) can be clamped
- adjustable from 0-4000 kg/cm²

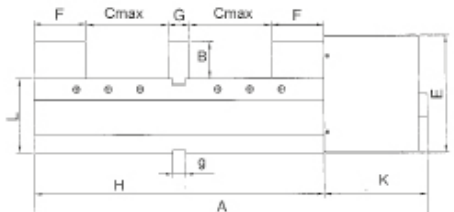
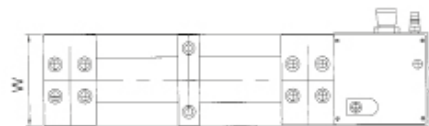

Typ / Type	A mm	H mm	K mm	W mm	E mm	F mm	G mm	B mm	Cmax mm	L mm	g mm	Max. Spannkraft / Clamping force daN	kg	Art.-Nr. / Order no.
115	556	410	146	130	166	74	30	52	115	105	18	3200	42	ZE-DPSP-130
150	656	510	146	160	168	82	30	55	155	105	18	4000	67	ZE-DPSP-160



Mehrfach-Spanneinrichtungen

Multiflex vices

Typ MFS

Type MFS

- zum Spannen von mehreren Werkstücken
- variable Anpassung der Spannelemente an die Werkstückabmessungen
- optimale Nutzung des Arbeitsbereichs einer Maschine
- horizontal einsetzbar
- mit Skalierung auf Spannleiste
- Lieferumfang: 1 Spannleiste, 1 feste Backe (glatt), 3 (bis L = 500 mm) oder 4 (ab L = 600 mm) Spannbacken (glatt)
- for clamping of multiple work pieces
- each clamping element individually adjustable
- optimum exploitation of machine's work-space
- for horizontal applications
- with scale for ease of handling
- scope of delivery: 1 clamping bar, 1 fixed jaw (plain), 3 (up to L = 500 mm) or 4 (from L = 600 mm) clamping jaws (plain)

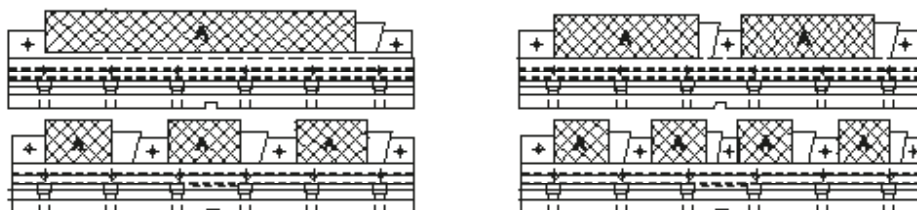
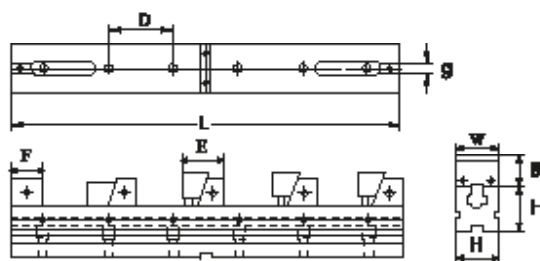
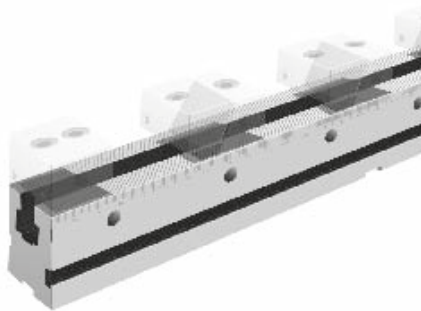

H	L	W	D	F	E	B	g	1xA	2xA	3xA	4xA	Max. Spann- kraft / Clamping force daN	Art.-Nr. / Order no.
50	300	49	100	38	55 - 58	25	16	208	75	30	8	1000	ZE-MFS-50/300
	400							308	125	64	33		ZE-MFS-50/400
	500							408	175	96	58		ZE-MFS-50/500
	600							508	225	129	83		ZE-MFS-50/600
	700							608	275	161	108		ZE-MFS-50/700
75	400	74	100	50	70 - 75	40	16	275	100	41	12	1500	ZE-MFS-75/400
	500							375	150	75	37		ZE-MFS-75/500
	600							475	200	108	62		ZE-MFS-75/600
	700							575	250	141	87		ZE-MFS-75/700
	800							675	300	174	112		ZE-MFS-75/800

Inkl. 4 Spannpratzen mit Nutensteinen und Schrauben, 2 Passsteine, 4 Werkstückanschläge, Spannschlüssel
 Incl. 4 brackets, t-nuts, screws, 2 key-nuts, 4 work piece stops and wrench

Ersatzbacken für Typ MFS

Spare jaws for type MFS

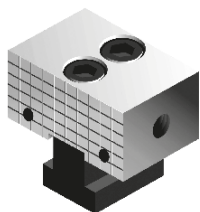

Feste Backe, Stück

Fixed jaw, piece

Für Typ / For type	W mm	L mm	kg	Art.-Nr. / Order no.
MFS50	49	38	0,4	<input checked="" type="checkbox"/> ZE-MFS-50FB
MFS75	74	50	1,3	<input checked="" type="checkbox"/> ZE-MFS-75FB

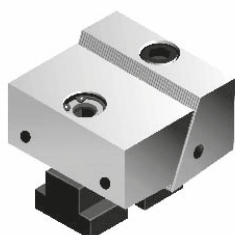

Bewegliche Backe, glatt, Stück

Movable jaw, plain, piece

Für Typ / For type	W mm	L mm	kg	Art.-Nr. / Order no.
MFS50	49	55 / 58	0,6	<input checked="" type="checkbox"/> ZE-MFS-50GB
MFS75	74	70 / 75	1,8	<input checked="" type="checkbox"/> ZE-MFS-75GB

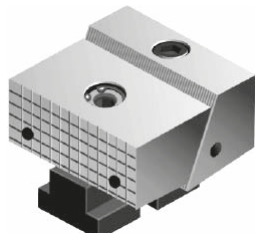

Bewegliche Backe, geriffelt, Stück

Movable jaw, serrated, piece

Für Typ / For type	W mm	L mm	kg	Art.-Nr. / Order no.
MFS50	49	55 / 58	0,6	<input checked="" type="checkbox"/> ZE-MFS-50RB
MFS75	74	70 / 75	1,8	<input checked="" type="checkbox"/> ZE-MFS-75RB

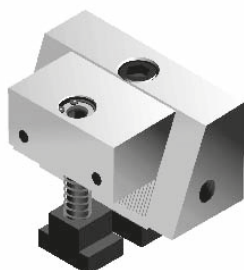

Bewegliche Backe, extrabreit, glatt, Stück

Movable jaw, enlarged, plain, piece

Für Typ / For type	W mm	L mm	kg	Art.-Nr. / Order no.
MFS50	63	56	1,1	<input checked="" type="checkbox"/> ZE-MFS-50XLB
MFS75	109	60	3	<input checked="" type="checkbox"/> ZE-MFS-75XLB



NC Schraubstöcke Typ MC2

NC precision power vices type MC2

Präzisions-Hochdruckspanner mit mechanischer Kraftverstärkung

High-power vice with mechanical force intensifier

Vorwahlstufe / Pre-selection	Spannkraft / Clamping force Typ / Type 125	Spannkraft / Clamping force Typ / Type 160	Spannkraft / Clamping force Typ / Type 200
0	500 daN	500 daN	500 daN
1	1100 daN	1300 daN	1500 daN
2	2500 daN	2700 daN	3200 daN
3	3700 daN	4000 daN	5100 daN
4	5000 daN	5400 daN	6800 daN



Typ MC2 type MC2

- Körper aus Guss FCD 65, Backen aus Stahl
- unten und seitlich geschliffen
- Anti-Lift-Mechanismus
- eingebauter Niederzug
- mechanische Kraftverstärkung, dichtunglos
- kurze Bauart
- Spannkraft voreinstellbar
- body made from cast iron FCD 65, jaws made from steel
- ground below and sideways
- "Anti-lifting" mechanism
- integrated pull down
- mechanical force increase, no seals required
- short body
- pre-selection of clamping force

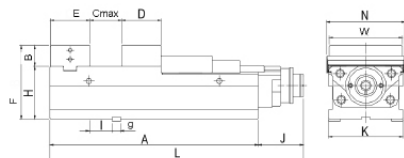

Typ MC2 / Type MC2	A mm	F mm	E mm	D mm	Cmax mm	B mm	g mm	H mm	I mm	J mm	K mm	L mm	W mm	N mm	kg	Art.-Nr. / Order no.
125	365	145	78	74	208	45	18	100	57	98,5	126	463,5	125	135	35	14-MC2-125
160	455	160	86	86	275	45	18	115	49	98,5	162	553,5	160	171	57	14-MC2-160
160M	480	160	86	86	300	45	18	115	49	98,5	162	578,5	160	174	63	14-MC2-160M
200	505	180	100	97	300	55	18	125	66	100	202	603,5	200	211	90	14-MC2-200

Inkl. 4 Spannpratzen, Hebeösen, Schlüssel und Nutensteine
Incl. clamping brackets, eye bolts, keys and t-nuts



Typ MC2 lang type MC2 long

- lange Version des Typs MC2
- extra große Spannweite
- long version of type MC2
- with large opening range

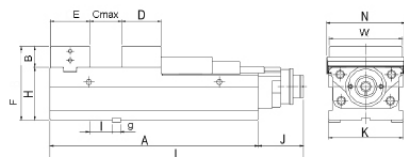

Typ MC2 / Type MC2	A mm	F mm	E mm	D mm	Cmax mm	B mm	g mm	H mm	I mm	J mm	K mm	L mm	W mm	N mm	kg	Art.-Nr. / Order no.
160L	535	160	86	86	355	45	18	115	49	98,5	162	633,5	160	174	64	14-MC2-160L
200L	610	180	100	97	405	55	18	125	66	100	202	708,5	200	214	103	14-MC2-200L

Inkl. 4 Spannpratzen, Hebeösen, Schlüssel und Nutensteine
Incl. clamping brackets, eye bolts, keys and t-nuts

Ersatzbacken für Schraubstöcke Typ MC2

Spare jaws for vices type MC2

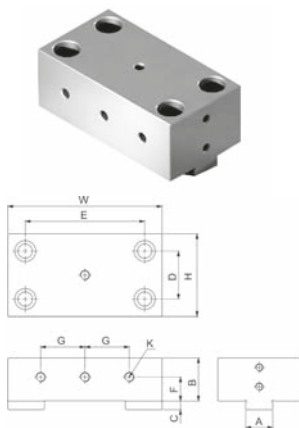

Feste Blockbacke, Stück

Fixed jaw, piece

Größe / Size	A mm	H mm	C mm	D mm	E mm	B mm	W mm	Art.-Nr. / Order no.
125	24	78	8	45	88	45	125	14-HJ-125
160	28	86	9	50	124	45	160	14-HJ-160
200	28	100	9	62	140	55	200	14-HJ-200

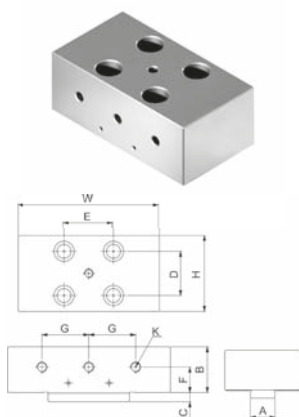

Bewegliche Blockbacke, Stück

Movable jaw, piece

Größe / Size	A mm	H mm	C mm	D mm	E mm	B mm	W mm	Art.-Nr. / Order no.
125	24	76	8	42	35	45	125	14-BHJ-125
160	28	86	9	50	56	45	160	14-BHJ-160
200	28	98	9	59	62	55	200	14-BHJ-200

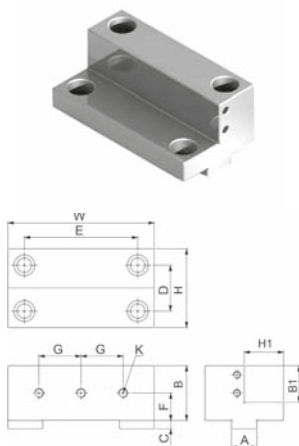

Feste Stufenbacke, Stück

Stepped jaw, fixed, piece

Größe / Size	A mm	H mm	H1 mm	C mm	D mm	E mm	B mm	B1 mm	W mm	Art.-Nr. / Order no.
125	24	78	38	8	45	88	50	32	125	14-LJ-125
160	28	86	43	8	50	124	60	40	160	14-LJ-160
200	28	98	49	9	62	140	70	45	200	14-LJ-200

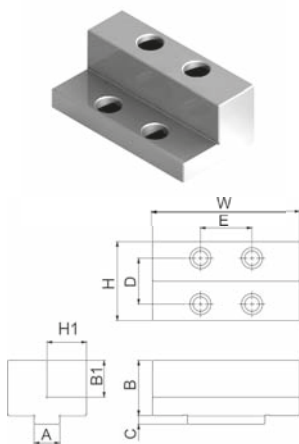

Bewegliche Stufenbacke, Stück

Stepped jaw, movable, piece

Größe / Size	A mm	H mm	H1 mm	C mm	D mm	E mm	B mm	B1 mm	W mm	Art.-Nr. / Order no.
125	24	76	38	8	42	35	50	32	125	14-BLJ-125
160	28	86	43	8	50	56	60	40	160	14-BLJ-160
200	28	98	49	9	59	62	70	45	200	14-BLJ-200

Weitere Ersatzbacken auf Anfrage
Further jaws available upon request



Ersatzbacken für Schraubstöcke Typ MC2

Spare jaws for vices type MC2

Prismenbacke, Stück

Prism jaw, piece

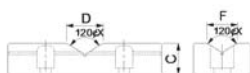
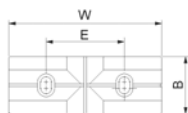

Größe / Size	W mm	B mm	C mm	D mm	F mm	E mm	G	Art.-Nr. / Order no.
125	125	47	25	30	25	64	M8	● 14-PB-125
160	160	62	30	30	30	92	M10	● 14-PB-160
200	200	72	30	30	30	100	M10	● 14-PB-200

Koordinaten-Prismenbacke, Stück

V-jaw, piece

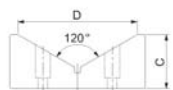
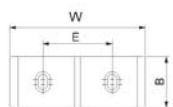

Größe / Size	W mm	B mm	C mm	D mm	E mm	G	Art.-Nr. / Order no.
125	125	47	50	110	64	M8	● 14-KB-125
160	160	62	55	130	92	M10	● 14-KB-160
200	200	72	55	130	100	M10	● 14-KB-200

Weitere Ersatzbacken auf Anfrage
Further jaws available upon request

Schraubstöcke Typ FHS2

Vices type FHS2



Hydraulischer Maschinenschraubstock Typ FHS2

Hydraulic machine vice type FHS2

- robuste Bauart mit mechanisch-hydraulischer Hochdruckspindel und großer Spannweite
- hohe Spanngenaugigkeit
- Schnellverstellung durch Steckbolzen
- alle Verschleißteile sind gehärtet, deshalb sowohl für schwere als auch leichte Zerspanung verwendbar
- sturdy design with hydraulic high-pressure spindle, mechanical drive and large clamping capacity
- high accuracy
- rapid clamping range adjustment with socket pins
- all wearing parts are hardened, therefore suitable for heavy- and light-duty machining operations

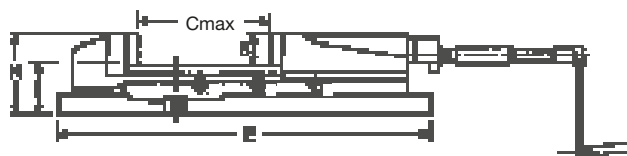
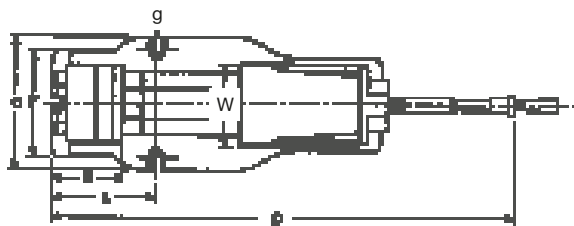

Typ / Type	W mm	B mm	Cmax mm	D mm	E mm	F mm	G mm	H mm	I mm	J mm	K mm	L mm	g mm	Spannkraft / Clamping force daN	kg	Art.-Nr. / Order no.
FHS 100	105	36	170	695	440	135	170	95	58	80	95	147	20	2500	21	14-FHS2-100
FHS 125	130	48	220	840	550	175	207	120	70,5	97	107	195	20	3500	38	14-FHS2-125
FHS 150	150	53	300	970	620	182	225	135	82,5	116	117	210	20	4500	53	14-FHS2-150
FHS 200	200	62	300	1070	680	260	280	162	100	160	150	260	20	8000	95	14-FHS2-200

Inkl. Kurbel, Verlängerung und glatten Backen
Incl. hand crank, extension and plain jaws

1.

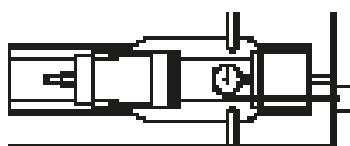

2.

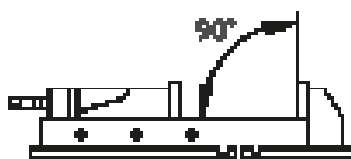

3.

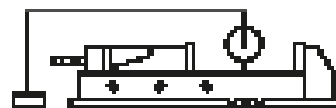

1	Parallelität der festen Backe zur Stirnseite / Parallelism of body face and fixed jaw clamp face	0,01 mm
2	Rechtwinkligkeit feste Backe zu Führungsbahn / Squareness of fixed jaw and jaw slideway	0,02 mm
3	Parallelität Auflagefläche zu Führungsbahn / Parallelism of body bottom face and jaw slideway	0,01 mm



Zubehör für Typ FHS2

Accessories for type FHS2



Drehplatte Swivel plate

Für Größe / For size	Art.-Nr. / Order no.
100	14-FHS2-100/S
125	14-FHS2-125/S
150	14-FHS2-150/S
200	14-FHS2-200/S



Glatte Backen, Satz Plain jaws, set

Für Größe / For size	Art.-Nr. / Order no.
100	14-FHS2-100/GB
125	14-FHS2-125/GB
150	14-FHS2-150/GB
200	14-FHS2-200/GB



Prismenbacke, Stück Prism jaw, piece

Für Größe / For size	Art.-Nr. / Order no.
100	14-FHS2-100/PB
125	14-FHS2-125/PB
150	14-FHS2-150/PB
200	14-FHS2-200/PB



Rillenbacken, Satz Grooved jaws, set

Für Größe / For size	Art.-Nr. / Order no.
100	14-FHS2-100/RB
125	14-FHS2-125/RB
150	14-FHS2-150/RB
200	14-FHS2-200/RB



Dichtungssatz Set of seals

Für Größe / For size	Art.-Nr. / Order no.
100	14-FHS2-100/D
125	14-FHS2-125/D
150	14-FHS2-150/D
200	14-FHS2-200/D

Alle Ersatzteile ab Lager lieferbar. Technischer Service in unserem Hause
All spare parts available in stock. Company-own technical service

Schraubstöcke Typ NCK2

Vices type NCK2

Typ NCK2 Type NCK2

- mechanisch-hydraulisch
 - eingebauter Niederzugeffekt
 - mit Schnellverstellung
 - Toleranz der Bauhöhe +/- 0.01 mm, somit für den Einsatz mehrerer Schraubstöcke nebeneinander geeignet
 - auch seitlich einsetzbar
 - Bett gehärtet HRC 45, Körper aus Guss FCD 60
- *mechanic-hydraulic*
 - *with pull down mechanism*
 - *with quick adjustment*
 - *height tolerance = +/- 0.01 mm, suitable for side by side application*
 - *can also be laterally mounted*
 - *hardened bed HRC 45, body made from cast iron FCD 60*

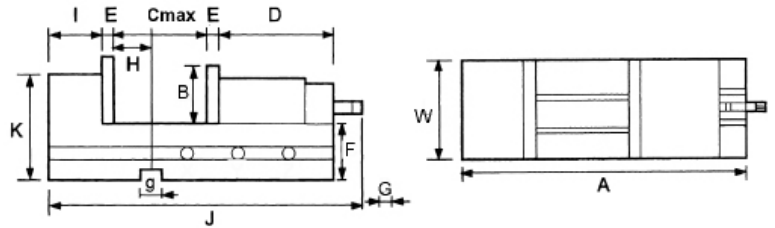

Typ / Type	A mm	G mm	F mm	D mm	E mm	Cmax mm	B mm	H mm	I mm	J mm	K mm	W mm	g mm	daN	kg	Art.-Nr. / Order no.
100	404	14	62	208	12,5	170	42	45	64,5	450-540	102	105	16	2500	22	14-NCK2-100
150	537	19	85	243	15,5	300	57	65	84,5	650-740	140	152	18	5000	50	14-NCK2-150
200	606	19	95	257	18,5	300	62	82	89,5	655-755	162	200	18	7000	80	14-NCK2-200

Parallelität der festen Backe zur Stirnseite / Parallelism of body face and fixed jaw clamp face	0,01 mm
Rechtwinkligkeit feste Backe zu Führungsbahn / Squareness of fixed jaw and jaw slideway	0,015 mm
Parallelität Auflagefläche zu Führungsbahn / Parallelism of body bottom face and jaw slideway	0,01 mm
Max. Hub eines Referenzwerkstücks / Max. lift of test block	0,02 mm
Parallelität Referenzwerkstück zu Auflagefläche / Parallelism of clamped test block and bottom face	0,015 mm



Fräsmaschinenschraubstöcke

Milling machine vices

Typ MSK ohne Drehplatte, mechanisch

Type MSK without swivel plate, mechanical

- für Fräs-, Schleif- und Bohrarbeiten
- Backen gehärtet und geschliffen
- for milling, grinding and drilling operations
- jaws hardened and ground

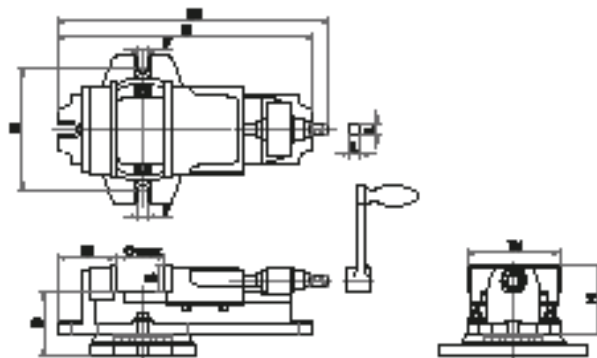
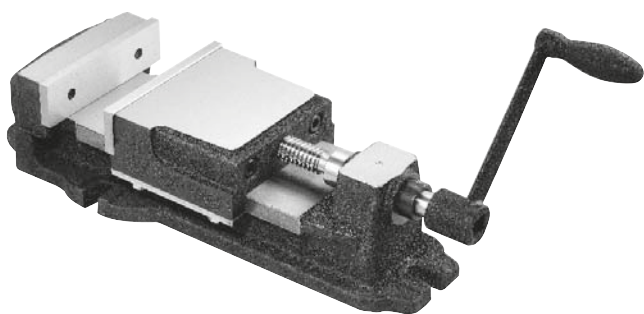

Typ / Type	W mm	B mm	Cmax mm	E mm	E1 mm	F mm	G mm	H mm	L mm	M mm	Max. Spann- kraft / Clamping force daN	kg	Art.-Nr. / Order no.
100	104	36	62	293	310	13	145	83	15	65	900	9	ZE-MSK100
125	130	37	82	362	384	13	172	97	15	84	900	15	ZE-MSK125
150	152	43	112	442	473	15	209	108	16,5	90	1000	26	ZE-MSK150
200	204	63	149	579	609	18	312	148	21	122	1400	53	ZE-MSK200

Typ MSK mit Drehplatte, mechanisch

Type MSK with swivel plate, mechanical

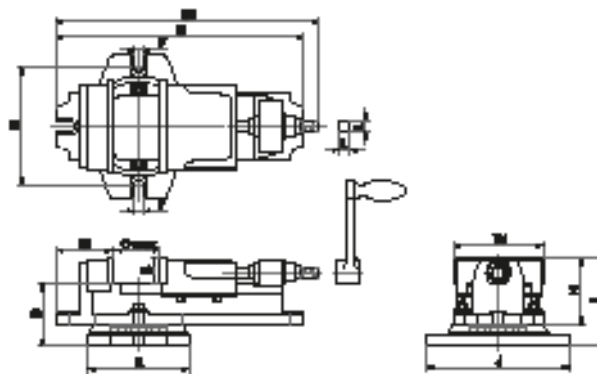

Typ / Type	W mm	B mm	Cmax mm	D mm	E mm	E1 mm	F mm	G mm	H mm	I mm	J mm	K mm	L mm	M mm	Max. Spann- kraft / Clamping force daN	kg	Art.-Nr. / Order no.
100	104	36	62	76	293	310	13	145	83	113	176	122	15	65	900	10	ZE-MSK100D
125	130	37	82	92	362	384	13	172	97	129	209	147	15	84	900	17	ZE-MSK125D
150	152	43	112	105	442	473	15	209	108	148	260	181	16,5	90	1000	28	ZE-MSK150D
200	204	63	149	127	579	609	18	312	148	190	350	234	21	122	1400	56	ZE-MSK200D

3-Achsen-Schraubstöcke 3-axes machine vices

Typ MSK3 Type MSK3

- 3-fach verstellbar
- 360° drehbar
- 0-90° vertikal verstellbar
- ± 45° schwenkbar
- Backen gehärtet und geschliffen
- adjustable in 3 ways
- 360° rotatable
- 0-90° vertically adjustable
- ± 45° tiltable
- jaws hardened and ground

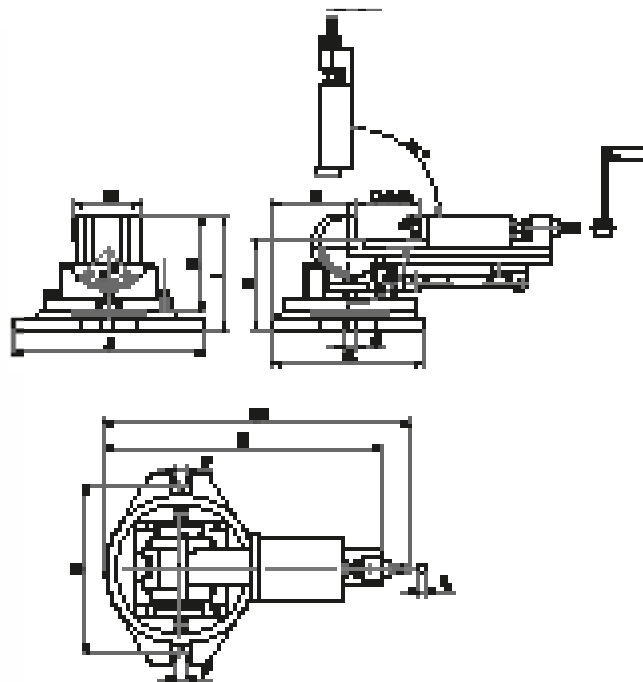

Typ / Type	W mm	B mm	Cmax mm	D mm	E mm	E1 mm	F mm	G mm	H mm	I mm	J mm	K mm	L mm	M mm	g	Max. Spann- kraft / Clamping force daN	kg	Art.-Nr. / Order no.
80	80	31	85	126	335	370	15	210	127	157	240	185	10	95	16	800	17	ZE-MSK3-080
110	110	38	115	152	448	497	17	276	157	190	311	245	13	135	16	1000	33	ZE-MSK3-110
135	135	40	150	170	530	580	17	310	173	210	358	271	13	140	16	1600	50	ZE-MSK3-135



Bohrmaschinen-Schraubstöcke

Drilling machine vices

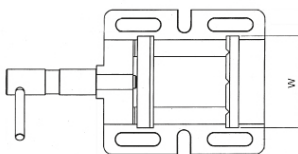
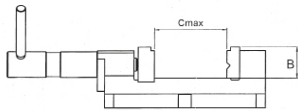

Bohrmaschinen-Schraubstock Typ MSP

Drilling machine vice type MSP

- Körper aus Guss
- Stahlbacken mit vertikalem und horizontalem Prisma
- cast iron body
- steel jaws with vertical and horizontal prism

Typ / Type	W mm	Cmax mm	B mm	kg	Art.-Nr. / Order no.
MSP 80	85	65	29	4	● OT-206085
MSP 100	100	85	33	5	● OT-206100
MSP 120	120	110	33	8	● OT-206120

Bohrmaschinen-Schraubstock Typ BMSR

Drilling machine vice type BMSR

- Körper aus Guss
- Backen gehärtet und geschliffen
- eine glatte Backe, eine Backe mit vertikalem und horizontalem Prisma
- robuste Ausführung
- cast iron body
- jaws hardened and ground
- one plain jaw, one jaw with vertical and horizontal prism
- rigid design

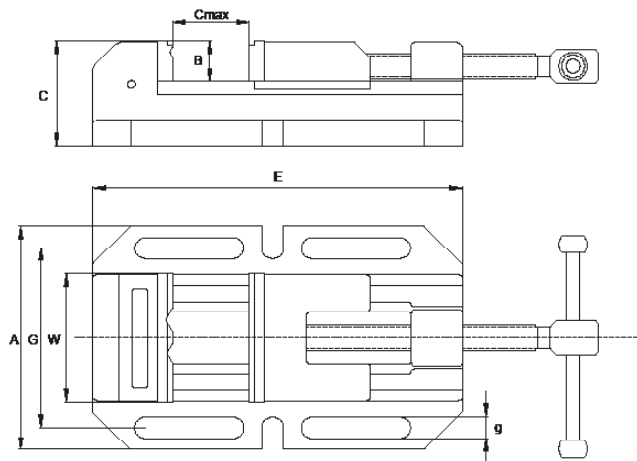

Typ / Type	W mm	Cmax mm	A mm	B mm	g mm	G mm	E mm	kg	Art.-Nr. / Order no.
BMSR 60	60	70	115	25	11	90	170	2,9	● ZE-BMSR-60
BMSR 100	100	130	178	32	17	140	288	11,7	● ZE-BMSR-100
BMSR 120	120	160	197	40	17	159	340	16,8	● ZE-BMSR-120
BMSR 150	150	200	227	40	17	190	400	23,3	● ZE-BMSR-150



Werkbankschraubstöcke

Table vices

Werkbankschraubstock Typ WBS

Table vice type WBS



Typ T
Type T

- sehr stabile Konstruktion
- Backen aus Hochqualitätsstahl, gehärtet auf 54 HRC \pm 5
- große Ambossfläche
- integrierte Drehplatte \pm 35° mit Positionsschrauben
- Typ T: mit Backen für Rundmaterial
- sturdy design
- jaws made from high-quality steel, hardened to 54 HRC \pm 5
- large anvil
- integrated swivel base \pm 35° with position screws
- type T: with pipe jaws

Typ / Type	W mm	Cmax mm	Spannkraft / Clamping force daN	kg	Art.-Nr. / Order no.
63	63	55	3500	4	14-WBS-063
80	80	70	3500	6	14-WBS-080
100	100	105	3500	12,5	14-WBS-100
125	125	115	3500	20	14-WBS-125
125T *	125	115	3500	20	14-WBS-125T
150	150	125	3500	30	14-WBS-150
150T *	150	125	3500	30	14-WBS-150T

* mit Backen für Rundmaterial
* with pipe jaws

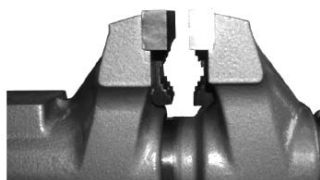

Typ T
Type T

- Schraubstock für große Belastungen
- auf Drehplatte, 360° drehbar
- Ambossfläche 70 x 150 mm
- Backen aus Hochqualitätsstahl, gehärtet auf 52 - 54 HRC
- Typ T: mit Backen für Rundmaterial
- heavy-duty vice
- swivel base, 360° rotatable
- large anvil 70 x 150 mm
- jaws made from high-quality steel, hardened to 52 - 54 HRC
- type T: with pipe jaws

Typ / Type	W mm	Cmax mm	Spannkraft / Clamping force daN	kg	Art.-Nr. / Order no.
200	200	200	5500	40	14-WBS-200
200T *	200	200	5500	40	14-WBS-200T
250	250	200	5500	45	14-WBS-250
250T *	250	200	5500	45	14-WBS-250T

* mit Backen für Rundmaterial
* with pipe jaws

Teleskophalter für Werkbank-Schraubstock

Telescopic holder for table vice



- Teleskophalter passend zu Typ WBS 100, 125, 150
- ermöglicht eine Höhenverstellung des Schraubstockes
- Einstellungsbereich: 0 - 200 mm
- telescopic holder suitable for types WBS 100, 125, 150
- for height adjustment of vices
- range of adjustment: 0 - 200 mm

Typ / Type	Höhenverstellung / Range of adjustment mm	kg	Art.-Nr. / Order no.
TP200	0-200	8,6	14-TP200



Zentrischspanner Typ ZSM2

Self-centering vices type ZSM2

Zentrischspanner Typ ZSM2

Self-centering vice type ZSM2

- Für 4/5-Achs-Bearbeitung
- Wiederholgenauigkeit: 0,01 mm
- mit Niederzugeffekt
- for 4/5-axes machining
- repeatability: 0,01 mm
- with pull-down mechanism

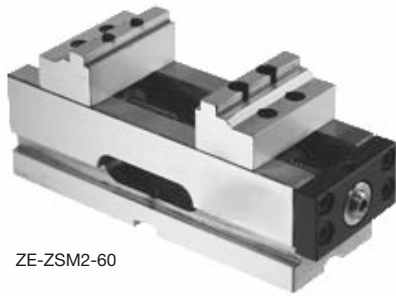

ZE-ZSM2-60

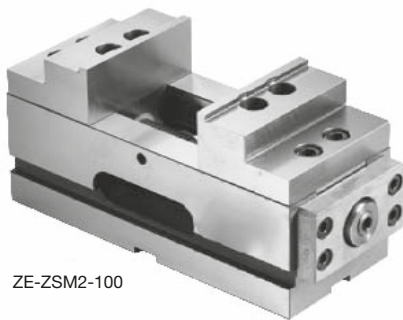
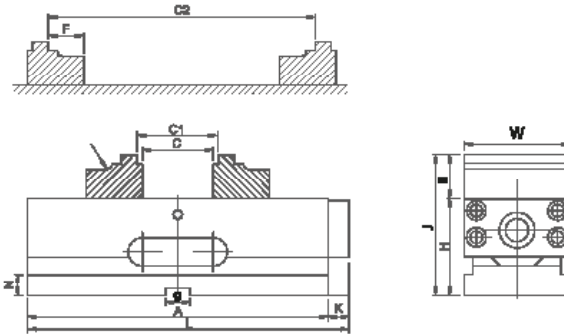

ZE-ZSM2-100

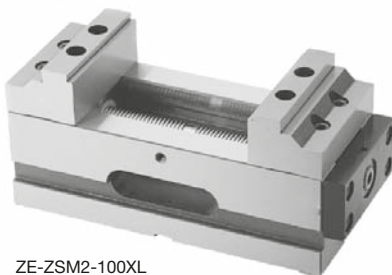
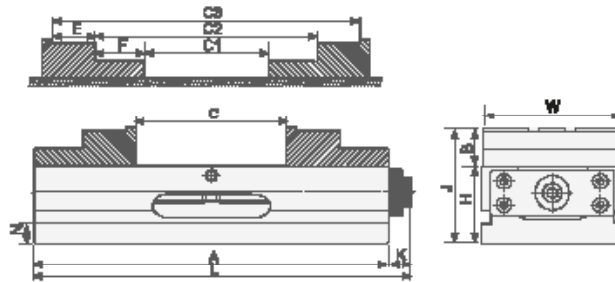

ZE-ZSM2-100XL

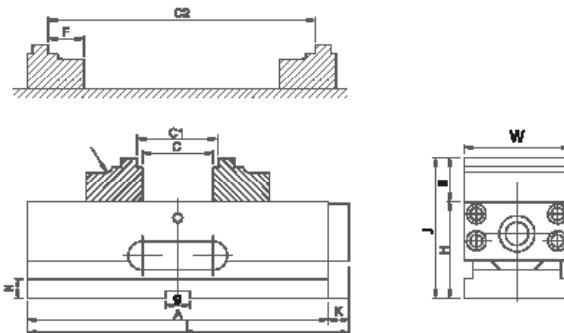

W mm	A mm	J mm	C1	C2	C3	F mm	H mm	B mm	K mm	N mm	g mm	L mm	Spann- kraft / Clamping force daN	Anzugs- moment/ Torque Nm	kg	Art.-Nr. / Order no.
Spannweite / Clamping range																
60	170	80	112	45-140	-	20	55	25	15	14	14	185	300	18	5	ZE-ZSM2-60
100	240	120	90	70-160	134-222	35	80	40	20	22	18	260	400	26	18	ZE-ZSM2-100
100	240	120	140	62-192	-	30	80	40	16	21	16	260	400	26	19	ZE-ZSM2-100XL

Inkl. 4 Spannpratzen und Schlüssel
Incl. 4 clamping brackets and key



5-Achsen-Zentrischspanner, Typ SR5 5-axes self-centering vices, type SR5



Zentrischspanner, Typ SR5 Self-centering vices, type SR5

- für 5-Achs-Bearbeitung
- runder Körper, für weniger Störkon-turen und geringeren Platzbedarf
- ideal zum Einsatz auf Rundtischen, Teilapparaten etc.
- suitable for 5-axis machining
- round body for less interference and less space requirement
- ideal for use with indexing spacers, rotary tables etc.

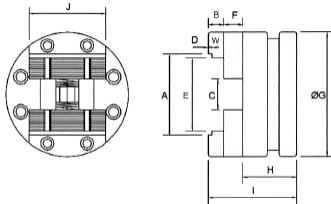

Typ / Type	A mm	E mm	C mm	D mm	B mm	F mm	G mm	H mm	I mm	W mm	Art.-Nr. / Order no.
100	105	95	40	5	20	25	160	70	115	100	14-SR5-100
130	135	125	50	5	20	25	210	80	125	130	14-SR5-130
160	165	155	60	5	25	25	250	90	140	160	14-SR5-160

Schleifschraubstöcke Tool maker vices

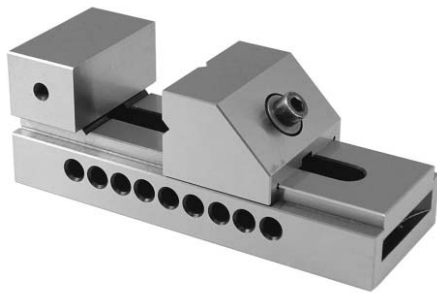

TMV-A, mit Schnellverstellung TMV-A, with quick adjustment

- aus Legierungsstahl, wärmebehandelt, gehärtet 58 HRC und feingeschliffen
- geeignet zum Einsatz auf Fräs- und Schleifmaschinen
- auch als Kontrollschraubstock verwendbar
- Parallelität: 0,005 mm / 100 mm
- Rechtwinkligkeit: 0,005 mm / 100 mm
- made from heat treated alloy steel, subzero treatment for stress relief against distortion, hardened 58 HRC and finished by grinding
- suitable for milling and grinding machines
- also suitable as reference for inspection
- parallelism: 0,005 mm / 100 mm
- squareness: 0,005 mm / 100 mm

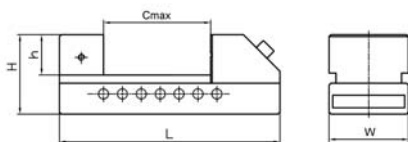

Typ / Type	W mm	H mm	Cmax mm	L mm	kg	Art.-Nr. / Order no.
A50	50	25	65	140	2	14-TMV-A50
A63	63	32	85	175	3	14-TMV-A63
A73	73	35	100	190	4	14-TMV-A73
A100	100	45	125	245	10	14-TMV-A100
A125	125	50	160	285	18	14-TMV-A125
A150	150	50	200	330	21	14-TMV-A150



TMV-B, mit Gewindespindel TMV-B, screw type

Typ / Type	W mm	H mm	Cmax mm	L mm	kg	Art.-Nr. / Order no.
B50	50	25	65	155	2	14-TMV-B50
B73	73	35	100	210	3,5	14-TMV-B73
B100	100	45	125	260	5	14-TMV-B100

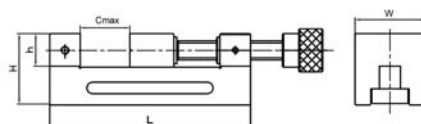

Sinus-Schraubstöcke

Sine vices

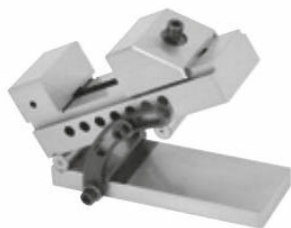

TMV-SA, mit Schnellverstellung

TMV-SA, with quick adjustment

- genaue Winkeleinstellung (0-45°) durch Endmaße
 - sichere Fixierung des Schraubstocks in jeder Winkeleinstellung
 - Parallelität: 0,005 mm / 100 mm
 - Rechtwinkligkeit: 0,005 mm / 100 mm
- accurate angle setting (0-45°) by gauge blocks
 - safe fixation in any angular position
 - parallelism: 0,005 mm / 100 mm
 - squareness: 0,005 mm / 100 mm

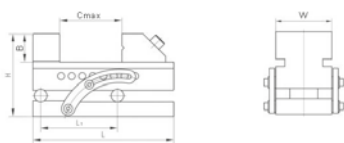

Typ / Type	W mm	B mm	H mm	Cmax mm	L mm	L1 mm	kg	Art.-Nr. / Order no.
SA63	63	32	92	85	175	100	5	14-TMV-SA63
SA73	73	35	104	100	190	100	9	14-TMV-SA73
SA88	88	40	122	125	235	100	11	14-TMV-SA88

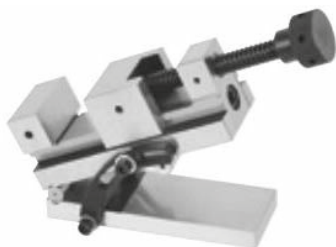

TMV-SB, mit Gewindespindel

TMV-SB, screw type

- Winkeleinstellung (0-45°)
- angle setting (0-45°)

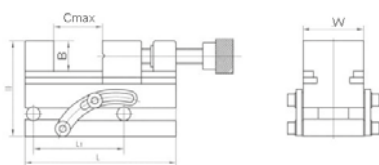

Typ / Type	W mm	B mm	H mm	Cmax mm	L mm	L1 mm	kg	Art.-Nr. / Order no.
SB63	63	32	94	85	175	100	5	14-TMV-SB63
SB73	73	35	111	90	190	100	9	14-TMV-SB73
SB100	100	45	139	125	245	100	17	14-TMV-SB100

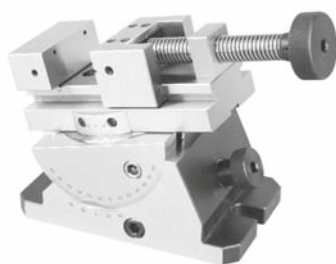

TMV-SB2, mit Gradeinteilungen

TMV-SB2, with scales

- in 2 Ebenen verstellbar
 - 360° drehbar, 60° schwenkbar
 - Nonius
 - Parallelität: 0,005 mm / 100 mm
 - Rechtwinkligkeit: 0,005 mm / 100 mm
- adjustable in 2 axes
 - 360° rotatable, 60° tiltable
 - vernier
 - parallelism: 0,005 mm / 100 mm
 - squareness: 0,005 mm / 100 mm

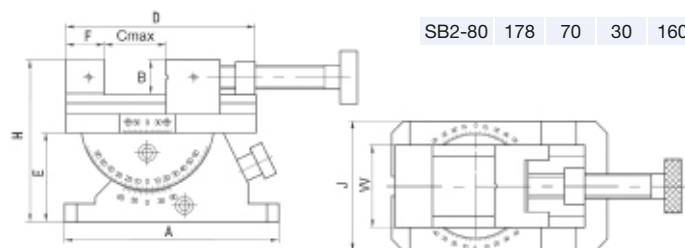

Typ / Type	A mm	W mm	B mm	D mm	E mm	F mm	Cmax mm	H mm	J mm	kg	Art.-Nr. / Order no.
SB2-80	178	70	30	160	75	33	80	137	110	14	14-TMV-SB2-80

Schleif- und Erodier-Schraubstöcke

Grinding and erosion vices

Typ SES, rostfrei

Type SES, noncorrosive



Abbildung 1 / figure 1

- geeignet für den Einsatz auf Erodier- und Schleifmaschinen für die präzise Bearbeitung von Werkstücken
- Material: nichtrostender Chromstahl 50 - 55 HRC
- Parallelität: 0,003 mm / 100 mm
- Rechtwinkligkeit: 0,003 mm / 100 mm

- suitable for milling, grinding and high precision operations
- material: stainless steel 50 - 55 HRC
- parallelism: 0,003 mm / 100 mm
- squareness: 0,003 mm / 100 mm



Abbildung 2 / figure 2



Typ / Type	Abbildung / figure	A mm	W mm	H mm	B mm	E mm	F mm	Cmax mm	kg	Art.-Nr. / Order no.
SES-25 Mini*	1	65	25	30	10	-	20	19	0,3	14-SES-25
N SES-25G	2	65	25	30	10	-	20	19	0,3	ZE-SES-25G
SES-50	2	140	50	53	25	28	25	75	1,8	14-SES-50
SES-72	2	180	72	62	30	32	35	100	3,8	14-SES-72

* mit Stufenbacke / with stepped jaw

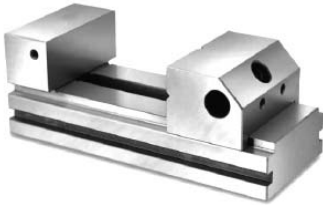
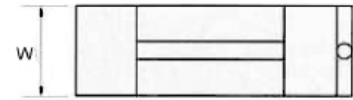
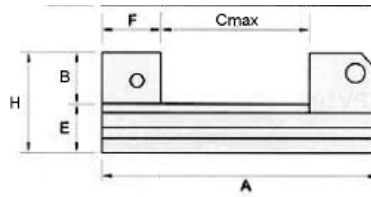
Typ SESP, rostfrei

Type SESP, noncorrosive

- hochgenauer Schraubstock, geeignet zum Einsatz auf Erodiermaschinen
- hohe Spannkraften garantieren stabile Positionierung der Werkstücke auch bei hohem Kühlmitteldruck
- Material: nichtrostender Chromstahl 54 HRC \pm 2
- Parallelität: 0,002 mm / 100 mm
- Rechtwinkligkeit: 0,002 mm / 100 mm

- high precision vise, suitable for use on eroding machines
- high clamping forces guarantee stable positioning of work piece even at high coolant pressure
- material: stainless steel, hardened treatment up to 54 HRC \pm 2
- parallelism: 0,002 mm / 100 mm
- squareness: 0,002 mm / 100 mm

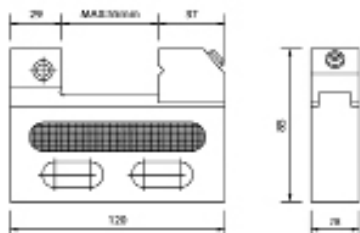

Cmax mm	kg	Art.-Nr. / Order no.
55	1	14-SESP-28/50

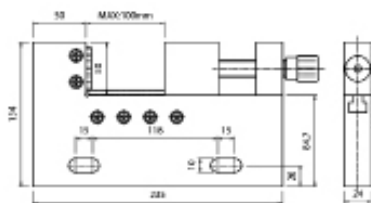

Cmax mm	kg	Art.-Nr. / Order no.
100	5	14-SESP-24/100

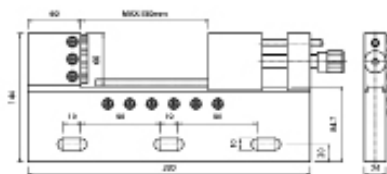
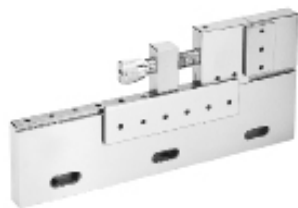

Cmax mm	kg	Art.-Nr. / Order no.
150	7	14-SESP-24/150

- in aufgespanntem Zustand justierbar in 3 Achsen
- nichtrostender Chromstahl, 45 - 55 HRC
- Parallelität: 0,003 mm / 100 mm
- Rechtwinkligkeit: 0,005 mm / 100 mm

- adjustable in 3 axes
- material: stainless steel, 45 - 55 HRC
- parallelism: 0,003 mm / 100 mm
- squareness: 0,005 mm / 100 mm

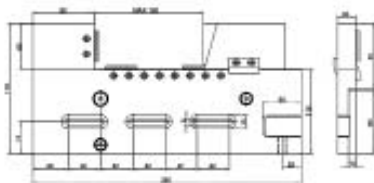

Cmax mm	kg	Art.-Nr. / Order no.
160	8	14-SESP-24/160

Erodier-Schraubstöcke

Erosion vices

- zum Spannen von Elektroden auf Erodiermaschinen
- Material: nichtrostender Chromstahl HRC 48 - 55
- Parallelität: 0,003 mm / 100 mm
- Rechtwinkligkeit: 0,005 mm / 100 mm
- for clamping of electrodes on eroding machines
- material: stainless steel, hardened treatment up to HRC 48 - 55
- parallelism: 0,003 mm / 100 mm
- squareness: 0,005 mm / 100 mm

Typ REHS, mit Schnellverstellung

Type REHS, with quick adjustment

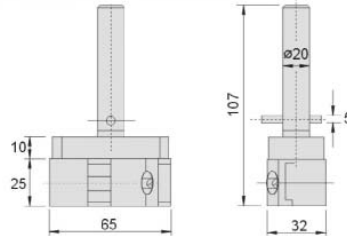

W mm	Cmax mm	kg	Art.-Nr. / Order no.
25	20	1	14-REHS-20

Typ REHG 20, mit Gewindespindel

Type REHG 20, screw type

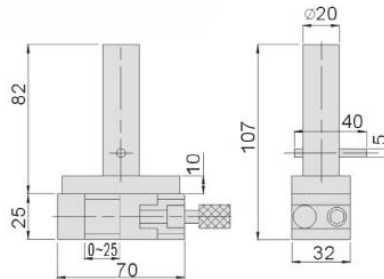

W mm	Cmax mm	kg	Art.-Nr. / Order no.
25	25	1	14-REHG-20

Typ REHG 50, mit Gewindespindel

Type REHG 50, screw type

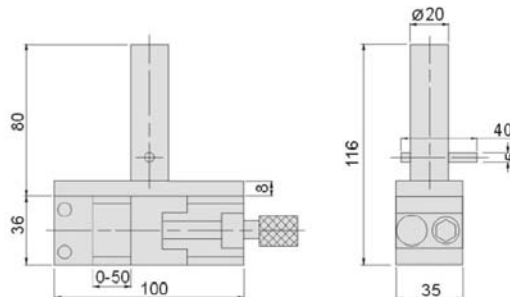

W mm	Cmax mm	kg	Art.-Nr. / Order no.
36	50	1,5	14-REHG-50



Zentrisch spannende Doppelschraubstöcke

Self-centering double vices

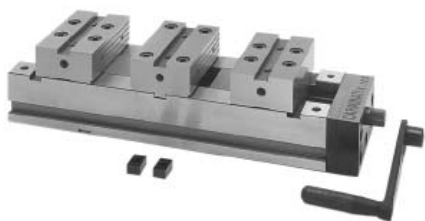

Typ EDMA.99, mechanisch

Type EDMA.99, mechanical

Einsatz horizontal oder seitlich.
Hochbelastbare Trapezspindel.

Used on level ground or on side.
Heavy-duty trapezoidal spindle.

Material: Legierter Stahl,
gehärtet und
geschliffen

Material: Hardened alloy
steel, precision
ground

Spannkraft: Typ 100: 1,8 t
Typ 125: 2,5 t
Typ 150: 3,5 t

Clamping force: Type 100: 1,8 t
Type 125: 2,5 t
Type 150: 3,5 t

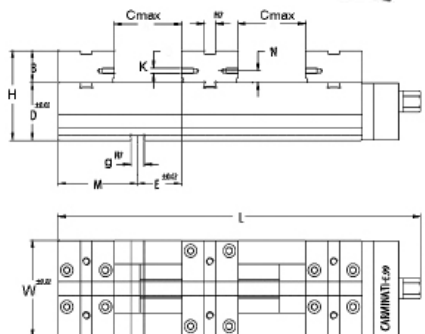

Typ / Type	Cmax mm	B mm	H mm	D mm	E mm	F mm	g mm	W mm	L mm	M mm	N mm	K mm	kg	Art.-Nr. / Order no.
100	80	33	93	60	46	12	14	100	374	82	12	M6	20	▶ 14-EDMA99-100
125	96	42	112	70	61	16	16	125	474	107	22	M6	38	▶ 14-EDMA99-125
150	145	52	132	80	61	16	16	150	584	162	22	M8	61	▶ 14-EDMA99-150

Präzisionsschraubstöcke mit Niederzugbacken

Precision vices with pull-down jaws



Typ SP.81, mechanisch - modulares System

Type SP.81, mechanical - modular system

Eigenschaften:

- Niederzugbacken drücken das Werkstück sicher nach unten
- beim Lösen gehen die Backen in die Ausgangsstellung zurück
- große Spannweite, schnelle Vor-einstellung über Kugelrastbolzen
- alle Teile sind gehärtet und geschliffen und ergeben höchste Präzision
- **Lieferung erfolgt ohne Drehplatte**

Main features:

- pull-down jaws which clamp the work piece on the plate under any conditions
- jaw return control
- wide opening and quick positioning for special machining
- all parts are hardened and ground
- **Supplied without swivel plate**

Material: Legierter Stahl,
gehärtet und
geschliffen

Material: Hardened alloy
steel, precision
ground

Spannkraft: Typ 100: 2,5 t
Typ 125: 3,5 t
Typ 150: 4 t
Typ 200: 5 t

Clamping force: Type 100: 2,5 t
Type 125: 3,5 t
Type 150: 4 t
Type 200: 5 t

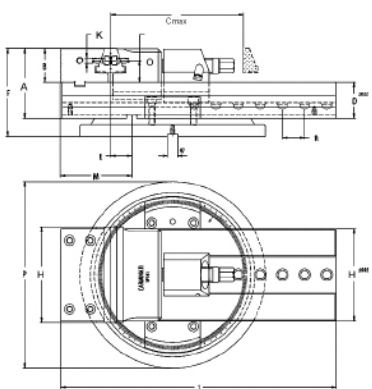

Typ / Type	Cmax mm	B mm	A mm	D mm	E mm	F mm	g mm	H mm	L mm	M mm	K mm	O mm	P mm	W mm	R mm	kg	Art.-Nr. / Order no.
100	120	39,5	79,5	40	1,5	102,5	14	95	301	61	M6	25,5	205	100	20	18	▶ 14-SP81-100
125	159	46	89	43	11,5	116	14	120	352	81	M6	30	238	125	27	28	▶ 14-SP81-125
150	210	53	110	57	33,5	138	16	145	435	112	M8	34	293	150	35	49	▶ 14-SP81-150
200	320	67	134	67	44	168	16	195	596	142	M8	43,5	343	200	40	97	▶ 14-SP81-200

- Lagerstandard / in stock
- ▶ innerhalb weniger Tage / within a few days
- auf Anfrage / on request
- * auslaufende Größe / as stock lasts



Präzisionsschraubstöcke mit Niederzugbacken

Precision vices with pull-down jaws



Typ ISP.81, mechanisch-hydraulisch - modulares System

Type ISP.81, mechanical-hydraulic - modular system

Präzisions-Schraubstock. Ausführung wie Grundmodell SP.81, jedoch mit eingebauter Hydraulikspindel und mechanischem Antrieb. Lieferung erfolgt ohne Drehplatte.

Precision vice. Design identical to basic model SP.81, however with integrated hydraulic/mechanic spindle. Supplied without swivel plate.

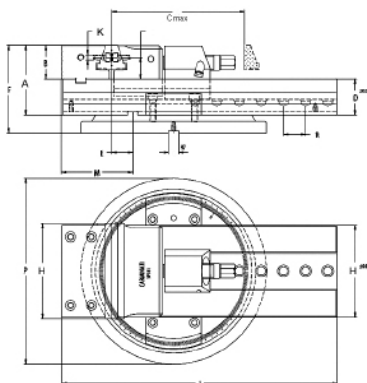

Material: Legierter Stahl, gehärtet und geschliffen

Material: Hardened alloy steel, precision ground

Spannkraft: Typ 100: 2 t
Typ 125: 3 t
Typ 150: 4 t
Typ 200: 5 t

Clamping force: Type 100: 2 t
Type 125: 3 t
Type 150: 4 t
Type 200: 5 t

Typ / Type	Cmax mm	B mm	A mm	D mm	E mm	F mm	g mm	H mm	L mm	M mm	K mm	O mm	P mm	W mm	R mm	kg	Art.-Nr. / Order no.
100	120	39,5	79,5	40	1,5	102,5	14	95	301	61	M6	25,5	205	100	20	19	▶ 14-ISP81-100
125	159	46	89	43	11,5	116	14	120	352	81	M6	30	238	125	27	29	▶ 14-ISP81-125
150	210	53	110	57	33,5	138	16	145	435	112	M8	34	293	150	35	51	▶ 14-ISP81-150
200	320	67	134	67	44	168	16	195	596	142	M8	43,5	343	200	40	99	▶ 14-ISP81-200



Typ OSP.81, pneumatisch-hydraulisch - modulares System

Type OSP.81, pneumatical-hydraulic - modular system

Präzisions-Schraubstock. Ausführung wie Grundmodell SP.81, jedoch mit eingebautem Hydraulikzylinder in Verbindung mit einem pneumatisch-hydraulischen Druckübersetzer; dadurch besonders geeignet für Serienfertigung. Die bewegliche Backe lässt sich leicht voreinstellen. Lieferung erfolgt inklusive Druckübersetzer, ohne Drehplatte.

Precision vice. Design identical to basic model SP.81, however with integrated hydraulic cylinder incl. pneumatic-hydraulic pressure multiplier. Especially suitable for series manufacture. The moveable jaw can easily be preadjusted. Supplied with pressure multiplier, without swivel plate.

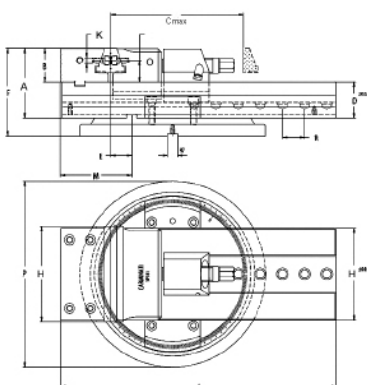

Material: Legierter Stahl, gehärtet und geschliffen

Material: Hardened alloy steel, precision ground

Hub: 6 mm

Stroke: 6 mm

Spannkraft: Typ 125: 2,5 t
(bei 8 bar)
Typ 150: 4,5 t
Typ 200: 5,5 t

Clamping force: Type 125: 2,5 t
(at 8 bar)
Type 150: 4,5 t
Type 200: 5,5 t

Typ / Type	Cmax mm	B mm	A mm	D mm	E mm	F mm	g mm	H mm	L mm	M mm	K mm	O mm	P mm	W mm	R mm	kg	Art.-Nr. / Order no.
125	159	46	89	43	11,5	116	14	120	352	81	M6	30	238	125	27	29	▶ 14-OSP81-125
150	210	53	110	57	33,5	138	16	145	435	112	M8	34	293	150	35	51	▶ 14-OSP81-150
200	320	67	134	67	44	168	16	195	596	142	M8	43,5	343	200	40	99	▶ 14-OSP81-200

Lieferbar auch mit verlängertem Bett auf Anfrage
Longer version available upon request



Universal-Werkstückanschlag

Universal stop-dog

Universal-Werkstückanschlag

Universal stop-dog



- Universal-Werkstückanschlag aus zweifarbig eloxiertem Aluminium für Bohr- und Fräsmaschinen
- durch die zwei Gelenkpfannen und den 360° drehbaren Kopf ist jede Einstell-Lage möglich
- inkl. Nutenstein (für 16, 18 und 20 mm T-Nuten), Anschlagstange und Inbuschlüssel
- universal two-coloured work piece stop, made from anodized aluminium for boring and milling machines
- two cranks and a knob (360° pivotable) allow any setting angle
- incl. t-nut (for 16, 18 and 20 mm), stop rod and hexagon wrench

Höhe Anschlagst. / Height of stop rod mm	Gesamthöhe / Total height mm	Anschlagst.-Ø / Stop rod dia. mm	Art.-Nr. / Order no.
155	215	8	09-AMS-160BH

Universal Aufsatz-Prismenbacken für Schraubstöcke

Universal prism jaws for vices



Universal Aufsatz-Prismenbacken mit Werkstückanschlag

Universal prism jaws with work stop

- geeignet für alle gängigen Schraubstöcke
- leicht und schnell montierbar
- suitable for all kinds of vices
- easy mounting and handling

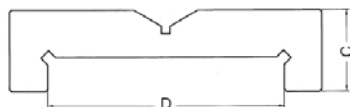
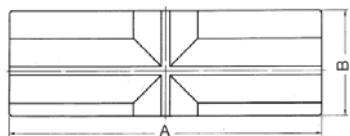

Für Backen- breite / For jaw width mm	A mm	D mm	C mm	B mm	kg	Art.-Nr. / Order no.
100-110	145	110	38	49	1,6	14-APB-100/110
125-140	175	140	39	49	1,7	14-APB-125/140
150-160	190	160	40	53	2	14-APB-150/160
200-210	245	210	42	76	4,2	14-APB-200/210

Preis pro Stück / Price per piece



VDI-Werkzeughalter

VDI-Tool holders



■ Inhalt:

- | Werkzeughalter DIN 69880
- | Stangengreifer
- | Kurzbohrfutter
- | Mitlaufende Zentrierspitzen
- | Pendelhalter
- | Räumwerkzeughalter
- | Werkstückanschläge
- | Prüfdorne
- | Einrichtehalter
- | Reduzierbuchsen, Kugelspritzdüsen, O-Ringe
- | Schutzstopfen

■ Content:

- | Tool holders DIN 69880
- | Bar pullers
- | Universal drill chucks
- | Revolving tailstock centres
- | Floating chucks
- | Broach tool holders
- | Work piece stops
- | Test arbors
- | Setting holders
- | Reduction sleeves, ball spray nozzles, O-rings
- | Protective plugs

VDI-Halter

VDI-Tool holders

Einsatz von Axial-Werkzeughaltern bei linker Spindeldrehrichtung

Application of axial tool holders with left-hand spindle rotation

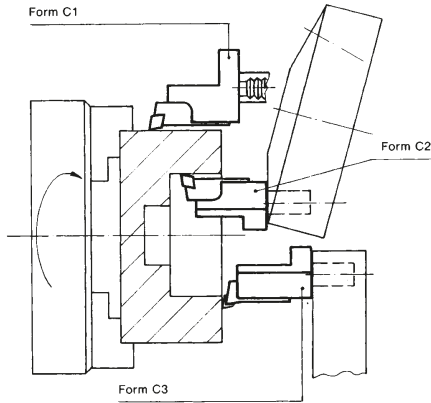

Einsatz von Radial-Werkzeughaltern bei linker Spindeldrehrichtung

Application of radial tool holders with left-hand spindle rotation

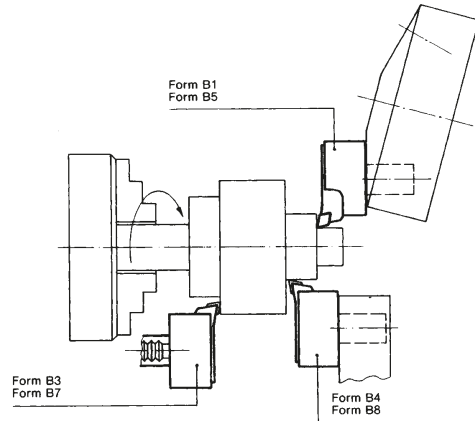

Einsatz von Axial-Werkzeughaltern bei rechter Spindeldrehrichtung

Application of axial tool holders with right-hand spindle rotation

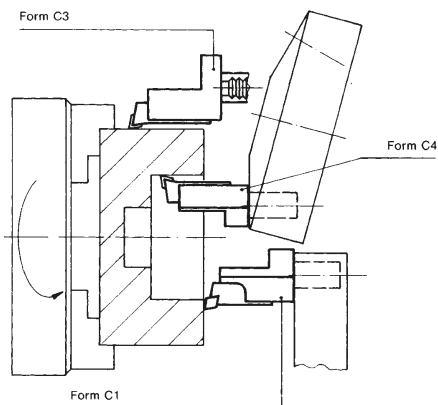

Einsatz von Radial-Werkzeughaltern bei rechter Spindeldrehrichtung

Application of radial tool holders with right-hand spindle rotation

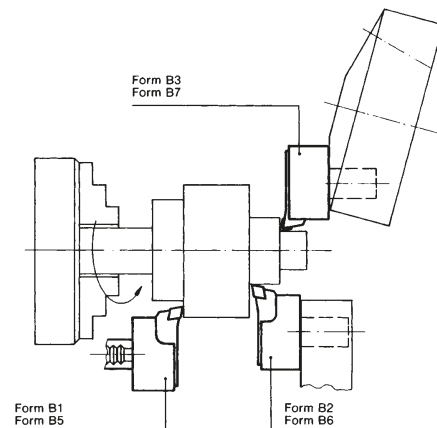

Typ A1, Werkzeughalter-Rohling, rechteckig*

Type A1, rectangular soft blank*

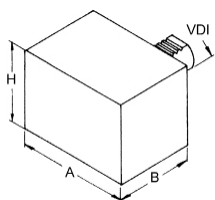

VDI	A mm	H mm	B mm	Art.-Nr. / Order no.
16	78	44	44	● 47-A1-16-44
20	100	60	65	● 47-A1-20-65
25	100	60	75	● 47-A1-25-75
30	130	76	85	● 47-A1-30-85
40	151	96	100	● 47-A1-40-100
40	60	96	220	✘ 47-A1-40-220
50	160	120	125	● 47-A1-50-125
60	165	125	160	● 47-A1-60-160

* Material 42 CRMo 4

Typ A2, Werkzeughalter-Rohling, rund*
Type A2, round soft blank*

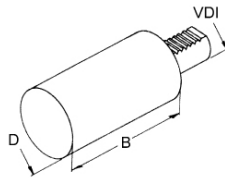

VDI	D mm	B mm	Art.-Nr. / Order no.
16	40	60	● 47-A2-16-60
20	50	70	● 47-A2-20-70
25	58	80	● 47-A2-25-80
25	58	200	● 47-A2-25-200
30	68	100	● 47-A2-30-100
30	68	240	● 47-A2-30-240
40	83	120	● 47-A2-40-120
40	83	320	● 47-A2-40-320
50	98	135	● 47-A2-50-135
50	98	400	● 47-A2-50-400
60	123	150	● 47-A2-60-150
60	123	480	● 47-A2-60-480

* Material: 42 CrMo 4

Typ B1, Radial-Werkzeughalter, rechts, kurz
Type B1, radial tool holder, right-hand, short

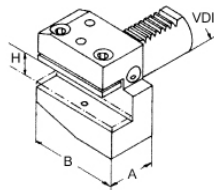

VDI	H mm	A mm	B mm	Art.-Nr. / Order no.
16	10/12	24	42	● 47-B1-16-12
20	12/16	30	55	● 47-B1-20-16
25	12/16	30	55	● 47-B1-25-16
30	16/20	40	70	● 47-B1-30-20
40	20/25	44	85	● 47-B1-40-25
50	25/32	55	100	● 47-B1-50-32
60	25/32	60	125	● 47-B1-60-32

Typ B2, Radial-Werkzeughalter, links, kurz
Type B2, radial tool holder, left-hand, short

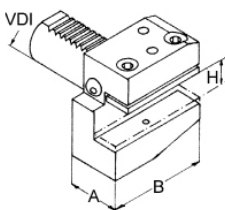

VDI	H mm	A mm	B mm	Art.-Nr. / Order no.
16	10/12	24	42	● 47-B2-16-12
20	12/16	30	55	● 47-B2-20-16
25	12/16	30	55	● 47-B2-25-16
30	16/20	40	70	● 47-B2-30-20
40	20/25	44	85	● 47-B2-40-25
50	25/32	55	100	● 47-B2-50-32
60	25/32	60	125	● 47-B2-60-32

Typ B3, Radial-Werkzeughalter, überkopf, rechts, kurz
Type B3, radial tool holder, inverted, right-hand, short

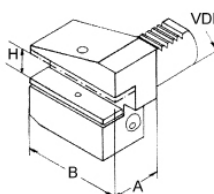

VDI	H mm	A mm	B mm	Art.-Nr. / Order no.
16	10/12	24	42	● 47-B3-16-12
20	12/16	30	55	● 47-B3-20-16
25	12/16	30	55	● 47-B3-25-16
30	16/20	40	70	● 47-B3-30-20
40	20/25	44	85	● 47-B3-40-25
50	25/32	55	100	● 47-B3-50-32
60	25/32	60	125	● 47-B3-60-32

VDI-Halter

VDI-Tool holders

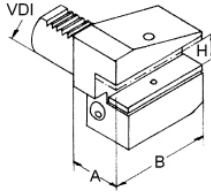

Typ B4, Radial-Werkzeughalter, überkopf, links, kurz

Type B4, radial tool holder, inverted, left-hand, short

VDI	H mm	A mm	B mm	Art.-Nr. / Order no.
16	10/12	24	42	● 47-B4-16-12
20	12/16	30	55	● 47-B4-20-16
25	12/16	30	55	● 47-B4-25-16
30	16/20	40	70	● 47-B4-30-20
40	20/25	44	85	● 47-B4-40-25
50	25/32	55	100	● 47-B4-50-32
60	25/32	60	125	● 47-B4-60-32

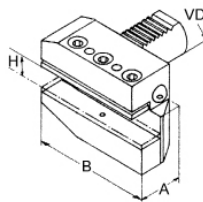

Typ B5, Radial-Werkzeughalter, rechts, lang

Type B5, radial tool holder, right-hand, long

VDI	H mm	A mm	B mm	Art.-Nr. / Order no.
16	10/12	24	58	● 47-B5-16-12
20	12/16	30	75	● 47-B5-20-16
25	12/16	30	75	● 47-B5-25-16
30	16/20	40	100	● 47-B5-30-20
40	20/25	44	118	● 47-B5-40-25
50	25/32	55	130	● 47-B5-50-32
60	25/32	60	145	● 47-B5-60-32

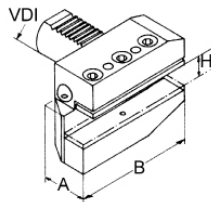

Typ B6, Radial-Werkzeughalter, links, lang

Type B6, radial tool holder, left-hand, long

VDI	H mm	A mm	B mm	Art.-Nr. / Order no.
16	10/12	24	58	● 47-B6-16-12
20	12/16	30	75	● 47-B6-20-16
25	12/16	30	75	● 47-B6-25-16
30	16/20	40	100	● 47-B6-30-20
40	20/25	44	118	● 47-B6-40-25
50	25/32	55	130	● 47-B6-50-32
60	25/32	60	145	● 47-B6-60-32

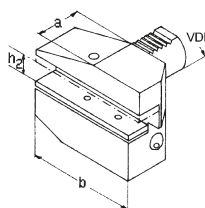

Typ B7, Radial-Werkzeughalter, überkopf, rechts, lang

Type B7, radial tool holder, inverted, right-hand, long

VDI	H mm	A mm	B mm	Art.-Nr. / Order no.
16	10/12	24	58	● 47-B7-16-12
20	12/16	30	75	● 47-B7-20-16
25	12/16	30	75	● 47-B7-25-16
30	16/20	40	100	● 47-B7-30-20
40	20/25	44	118	● 47-B7-40-25
50	25/32	55	130	● 47-B7-50-32
60	25/32	60	145	● 47-B7-60-32

- Lagerstandard / in stock
- ▶ innerhalb weniger Tage / within a few days
- auf Anfrage / on request
- * auslaufende Größe / as stock lasts



VDI-Halter

VDI-Tool holders

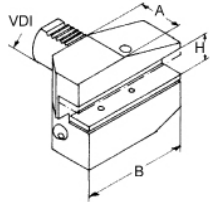

Typ B8, Radial-Werkzeughalter, überkopf, links, lang
Type B8, radial tool holder, inverted, left-hand, long

VDI	H mm	A mm	B mm	Art.-Nr. / Order no.
16	10/12	24	58	47-B8-16-12
20	12/16	30	75	47-B8-20-16
25	12/16	30	75	47-B8-25-16
30	16/20	40	100	47-B8-30-20
40	20/25	44	118	47-B8-40-25
50	25/32	55	130	47-B8-50-32
60	25/32	60	145	47-B8-60-32

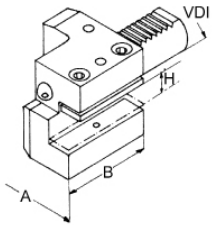

Typ C1, Axial-Werkzeughalter, rechts
Type C1, axial tool holder, right-hand

VDI	H mm	A mm	B mm	Art.-Nr. / Order no.
16	10/12	43	44	47-C1-16-12
20	12/16	52	50	47-C1-20-16
25	12/16	58	55	47-C1-25-16
30	16/20	76	70	47-C1-30-20
40	20/25	85	85	47-C1-40-25
50	25/32	100	100	47-C1-50-32
60	25/32	125	125	47-C1-60-32

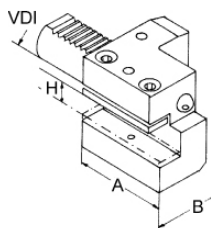

Typ C2, Axial-Werkzeughalter, links
Type C2, axial tool holder, left-hand

VDI	H mm	A mm	B mm	Art.-Nr. / Order no.
16	10/12	43	44	47-C2-16-12
20	12/16	52	50	47-C2-20-16
25	12/16	58	55	47-C2-25-16
30	16/20	76	70	47-C2-30-20
40	20/25	85	85	47-C2-40-25
50	25/32	100	100	47-C2-50-32
60	25/32	125	125	47-C2-60-32

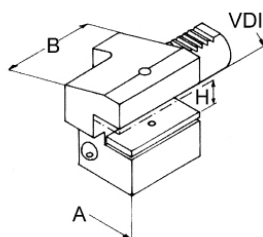

Typ C3, Axial-Werkzeughalter, überkopf, rechts
Type C3, axial tool holder, inverted, right-hand

VDI	H mm	A mm	B mm	Art.-Nr. / Order no.
16	10/12	43	44	47-C3-16-12
20	12/16	52	50	47-C3-20-16
25	12/16	58	55	47-C3-25-16
30	16/20	76	70	47-C3-30-20
40	20/25	85	85	47-C3-40-25
50	25/32	100	100	47-C3-50-32
60	25/32	125	125	47-C3-60-32



VDI-Halter

VDI-Tool holders

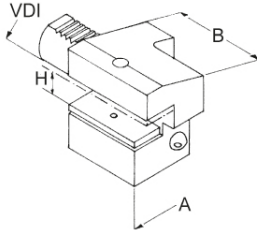

Typ C4, Axial-Werkzeughalter, überkopf, links

Type C4, axial tool holder, inverted, left-hand

VDI	H mm	A mm	B mm	Art.-Nr. / Order no.
16	10/12	43	44	● 47-C4-16-12
20	12/16	52	50	● 47-C4-20-16
25	12/16	58	55	● 47-C4-25-16
30	16/20	76	70	● 47-C4-30-20
40	20/25	85	85	● 47-C4-40-25
50	25/32	100	100	● 47-C4-50-32
60	25/32	125	125	● 47-C4-60-32



Typ D1, Vierkant-Mehrfach-Aufnahme

Type D1, multiple square tool holder

VDI	H mm	A mm	B mm	Art.-Nr. / Order no.
25	12/16	66	48	● 47-D1-25-16
30	16/20	76	60	● 47-D1-30-20
40	20/25	90	72	● 47-D1-40-25
50	25/32	105	85	● 47-D1-50-32



Typ D2, Vierkant-Mehrfach-Aufnahme, überkopf

Type D2, multiple square tool holder, inverted

VDI	H mm	A mm	B mm	Art.-Nr. / Order no.
25	12/16	66	48	● 47-D2-25-16
30	16/20	76	60	● 47-D2-30-20
40	20/25	90	72	● 47-D2-40-25
50	25/32	105	85	● 47-D2-50-32

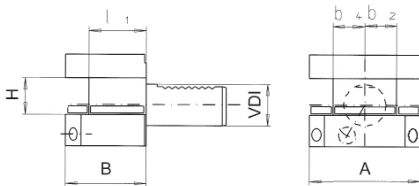

Abstechhalter, rechts

Parting off tool holder, right-hand

VDI	H mm	A mm	B mm	L mm	Art.-Nr. / Order no.
30	26	71	70	50	● 47-AR-30-26
40	26	84,5	85	50	● 47-AR-40-26
40	32	84,5	85	50	● 47-AR-40-32
50	32	88	100	50	● 47-AR-50-32

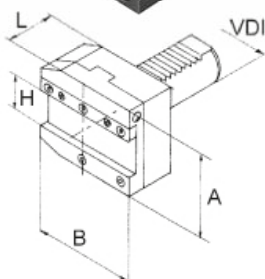

- Lagerstandard / in stock
- ▶ innerhalb weniger Tage / within a few days
- auf Anfrage / on request
- * auslaufende Größe / as stock lasts



VDI-Halter

VDI-Tool holders

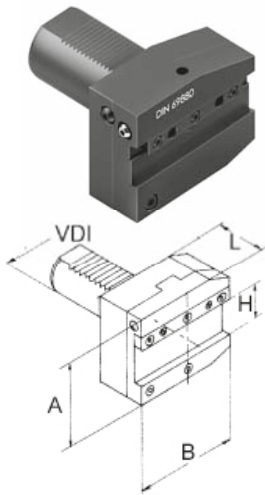

Abstechhalter, links

Parting off tool holder, left-hand

VDI	H mm	A mm	B mm	L mm	Art.-Nr. / Order no.
30	26	71	70	50	● 47-AL-30-26
40	26	84,5	85	50	● 47-AL-40-26
40	32	84,5	85	50	● 47-AL-40-32
50	26	88	100	50	● 47-AL-50-26
50	32	88	100	50	● 47-AL-50-32

Typ E1, Wendepplatten-Bohrerhalter, IK

Type E1, U-drill holder, IK

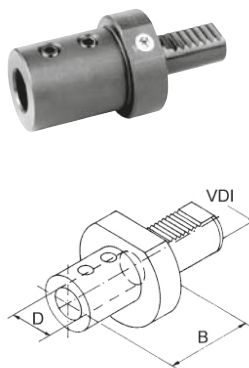

VDI	D mm	B mm	Art.-Nr. / Order no.
20	16	66	● 47-E1-20-16
20	20	67	● 47-E1-20-20
20	25	71	● 47-E1-20-25
25	20	67	● 47-E1-25-20
25	25	71	● 47-E1-25-25
30	10	66	● 47-E1-30-10
30	12	66	● 47-E1-30-12
30	16	66	● 47-E1-30-16
30	20	67	● 47-E1-30-20
30	25	71	● 47-E1-30-25
30	32	75	● 47-E1-30-32
30	40	90	● 47-E1-30-40
40	10	66	● 47-E1-40-10
40	12	66	● 47-E1-40-12
40	14	66	● 47-E1-40-14
40	16	66	● 47-E1-40-16
40	20	67	● 47-E1-40-20
40	25	75	● 47-E1-40-25
40	32	75	● 47-E1-40-32
40	40	90	● 47-E1-40-40
40	50	100	● 47-E1-40-50
50	20	67	● 47-E1-50-20
50	25	80	● 47-E1-50-25
50	32	80	● 47-E1-50-32
50	40	90	● 47-E1-50-40
50	50	100	● 47-E1-50-50
60	25	80	● 47-E1-60-25
60	32	80	● 47-E1-60-32
60	40	90	● 47-E1-60-40
60	50	100	● 47-E1-60-50

Beliebige Innendurchmesser, Zwischengrößen, Zollmaße etc. lieferbar auf Anfrage
Other internal diameters, intermediary bores, inch bores etc. available upon request



VDI-Halter

VDI-Tool holders

Typ E2, Bohrstangenhalter, IK/EK Type E2, boring bar holder, IC/EC

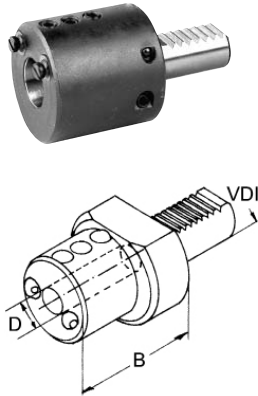

VDI	D mm	B mm	Art.-Nr. / Order no.
16	6	44	● 47-E2-16-06
16	8	44	● 47-E2-16-08
16	10	44	● 47-E2-16-10
16	12	44	● 47-E2-16-12
16	16	44	● 47-E2-16-16
20	8	50	● 47-E2-20-08
20	10	50	● 47-E2-20-10
20	12	50	● 47-E2-20-12
20	16	50	● 47-E2-20-16
20	20	50	● 47-E2-20-20
20	25	60	● 47-E2-20-25
25	8	50	● 47-E2-25-08
25	10	50	● 47-E2-25-10
25	12	50	● 47-E2-25-12
25	16	50	● 47-E2-25-16
25	20	50	● 47-E2-25-20
25	25	60	● 47-E2-25-25
30	6	60	● 47-E2-30-06
30	8	60	● 47-E2-30-08
30	10	60	● 47-E2-30-10
30	12	60	● 47-E2-30-12
30	16	60	● 47-E2-30-16
30	20	60	● 47-E2-30-20
30	25	60	● 47-E2-30-25
30	32	75	● 47-E2-30-32
40	6	75	● 47-E2-40-06
40	8	75	● 47-E2-40-08
40	10	75	● 47-E2-40-10
40	12	75	● 47-E2-40-12
40	16	75	● 47-E2-40-16
40	20	75	● 47-E2-40-20
40	25	75	● 47-E2-40-25
40	32	75	● 47-E2-40-32
40	40	90	● 47-E2-40-40
40	50	90	● 47-E2-40-50
50	10	75	● 47-E2-50-10
50	12	90	● 47-E2-50-12
50	16	90	● 47-E2-50-16
50	20	90	● 47-E2-50-20
50	25	90	● 47-E2-50-25
50	32	90	● 47-E2-50-32
50	40	90	● 47-E2-50-40
50	50	100	● 47-E2-50-50
60	12	90	● 47-E2-60-12
60	16	90	● 47-E2-60-16
60	20	90	● 47-E2-60-20
60	25	90	● 47-E2-60-25
60	32	90	● 47-E2-60-32
60	40	90	● 47-E2-60-40
60	50	100	● 47-E2-60-50

**Beliebige Innendurchmesser, Zwischengrößen, Zollmaße etc.
lieferbar auf Anfrage**
**Other internal diameters, intermediary bores, inch bores etc.
available upon request**

Typ E3, Spannzangenfutter OZ, für Spannzangen DIN 6388
Type E3, collet chucks OZ, for collets DIN 6388



VDI	OZ	D mm	Spannbereich / Clamping range	B mm	Art.-Nr. / Order no.
16	415 E	40	2-16	65	● 47-E3-16-16
20	415 E	50	2-16	57	● 47-E3-20-16
20	4541 E	50	4-20	62	● 47-E3-20-20
25	415 E	58	2-16	57	● 47-E3-25-16
30	462 E	68	2-25	75	● 47-E3-30-25
40	462 E	83	2-25	75	● 47-E3-40-25
40	467 E	83	4-32	90	● 47-E3-40-32
50	462 E	98	2-25	75	● 47-E3-50-25
50	467 E	98	4-32	90	● 47-E3-50-32
60	467 E	123	4-32	90	● 47-E3-60-32

Typ E4, Spannzangenfutter ER, für Spannzangen DIN 6499
Type E4, collet chucks ER, for collets DIN 6499

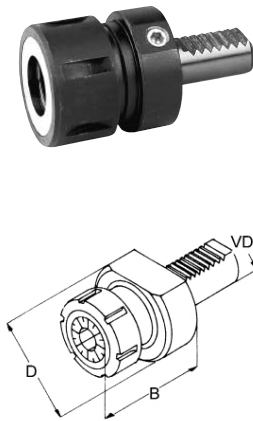

VDI	ER	D mm	Spannbereich / Clamping range	B mm	Art.-Nr. / Order no.
16	ER 16	40	1-10	40	● 47-E4-16-16
16	ER 20	40	1-13	44	● 47-E4-16-20
20	ER 16	50	1-10	40	● 47-E4-20-16
20	ER 20	50	1-13	44	● 47-E4-20-20
20	ER 25	50	1-16	54	● 47-E4-20-25
20	ER 32	50	2-20	40	● 47-E4-20-32
25	ER 25	58	1-16	57	● 47-E4-25-25
25	ER 32	58	2-20	62	● 47-E4-25-32
30	ER 25	68	1-16	53	● 47-E4-30-25
30	ER 32	68	2-20	62	● 47-E4-30-32
30	ER 40	68	2-25	53	● 47-E4-30-40
40	ER 25	83	1-16	53	● 47-E4-40-25
40	ER 32	83	2-20	84	● 47-E4-40-32
40	ER 40	83	2-25	75	● 47-E4-40-40
50	ER 32	98	2-20	84	● 47-E4-50-32
50	ER 40	98	2-25	90	● 47-E4-50-40
60	ER 40	123	2-25	75	● 47-E4-60-40

Typ E2S, Werkzeughalter geschlitzt, schwingungsarm
Type E2S, toolholder slotted, reduced vibration

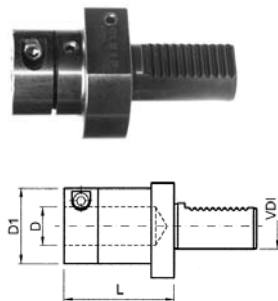

VDI	D mm	D1 mm	L mm	Art.-Nr. / Order no.
30	6	30	57	● 47-E2S-30-06
30	8	30	57	● 47-E2S-30-08
30	10	36	57	● 47-E2S-30-10
30	12	36	57	● 47-E2S-30-12
30	16	40	57	● 47-E2S-30-16
30	20	44	57	● 47-E2S-30-20
30	25	49	72	● 47-E2S-30-25
30	32	56	72	● 47-E2S-30-32
40	10	36	62	● 47-E2S-40-10
40	12	36	62	● 47-E2S-40-12
40	16	40	62	● 47-E2S-40-16
40	20	44	62	● 47-E2S-40-20
40	25	49	77	● 47-E2S-40-25
40	32	56	77	● 47-E2S-40-32
40	40	64	77	● 47-E2S-40-40

VDI-Halter

VDI-Tool holders

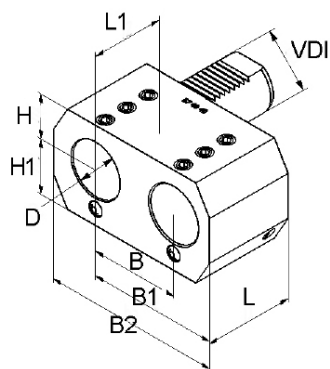

Typ E7, Doppel-Bohrstangenhalter

Typ E7, Boring bar holders with 2 bores

VDI	D mm	H mm	H1 mm	L mm	L1 mm	B mm	B1 mm	B2 mm	Art.-Nr. / Order no.
20	16	25	25	45	42	32	51	76	● 47-E7-20-16
20	20	25	25	45	42	32	51	76	● 47-E7-20-20
30	25	28	32	56	52	45	65	95	● 47-E7-30-25
40	32	32,5	40	66	60	50	75	115	● 47-E7-40-32
50	32	32,5	47,5	60	60	50	75	115	● 47-E7-50-32
50	40	42	46	66	60	68	103	145	● 47-E7-50-40
50	50	35	49	90	80	68	103	152	● 47-E7-50-50

Typ E8, Doppel-Bohrstangenhalter

Typ E8, Boring bar holders with 2 bores

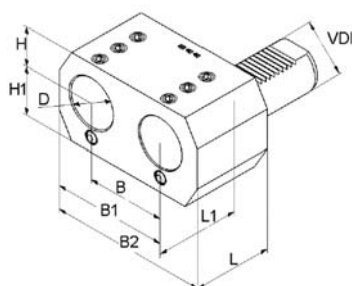

VDI	D mm	H mm	H1 mm	L mm	L1 mm	B mm	B1 mm	B2 mm	Art.-Nr. / Order no.
20	16	25	25	45	42	32	51	76	● 47-E8-20-16
20	20	25	25	45	42	32	51	76	● 47-E8-20-20
30	25	28	32	56	52	45	65	95	● 47-E8-30-25
40	32	32,5	40	66	60	50	75	115	● 47-E8-40-32
50	32	32,5	47,5	60	60	50	75	115	● 47-E8-50-32
50	50	35	49	90	80	68	103	152	● 47-E8-50-50

VDI-Halter

VDI-Tool holders

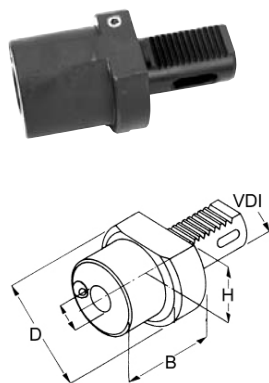

Typ F, Morsekegelaufnahme

Type F, Morse taper holder

VDI	MK / MT	H mm	D mm	B mm	Art.-Nr. / Order no.
20	1	23	50	22	● 47-F20-1
20	2	23	50	61	● 47-F20-2
25	1	25	58	22	● 47-F25-1
25	2	25	58	46	● 47-F25-2
30	1	28	68	27	● 47-F30-1
30	2	28	68	36	● 47-F30-2
30	3	28	68	66	● 47-F30-3
40	1	32,5	83	36	● 47-F40-1
40	2	32,5	83	36	● 47-F40-2
40	3	32,5	83	50	● 47-F40-3
40	4	32,5	83	80	● 47-F40-4
50	2	35	98	36	● 47-F50-2
50	3	35	98	45	● 47-F50-3
50	4	35	98	55	● 47-F50-4
50	5	35	98	72	● 47-F50-5
60	3	42,5	123	36	● 47-F60-3
60	4	42,5	123	50	● 47-F60-4
60	5	42,5	123	81	● 47-F60-5

Stangengreifer Bar pullers

Stangengreifer, Typ SGF Bar pullers, type SGF

- für zwei Spannbereiche
- mit Wendebacken

- for two clamping ranges
- with reversible clamping jaws

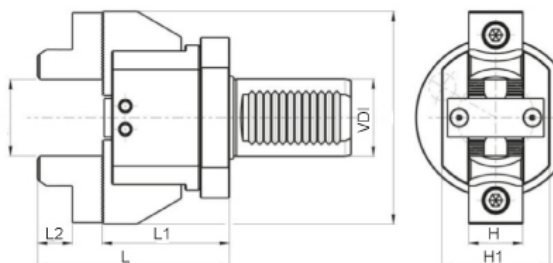
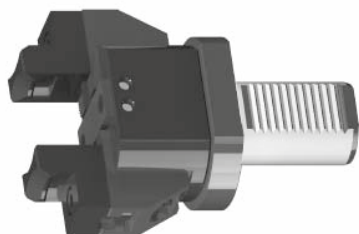

VDI	Spannbereich / Clamp.range	H mm	H1 mm	L mm	L1 mm	L2 mm	B mm	Art.-Nr. / Order no.
Zyl. / cyl. 32	6-110	28	56	100	66	18	110	47-SGF32Z
20	6-110	28	56	100	66	18	110	47-SGF20
30	6-110	28	56	100	66	18	110	47-SGF30
40	6-110	28	56	100	66	18	110	47-SGF40
50	6-110	28	56	100	66	18	110	47-SGF50

Stangengreifer, Typ SG25 Bar pullers, type SG25

- zylindrische Aufnahme D25 mit Spannfläche
- mit diamantbeschichteten Rollen für sicheren Halt, minimiert das Risiko einer Beschädigung des Rohmaterials
- stufenlose Einstellung auf jeden Durchmesser mit Hilfe der angebrachten Skala
- großer Spannbereich, verstellbar 1-70 mm, schnelle Verstellung des neuen Spannbereichs
- kompaktes Aluminium-Leichtgehäuse, blau eloxiert
- Lieferumfang: Stangengreifer inkl. 1 Paar Spannbacken mit diamantbeschichteten Rollen, 1 Paar feste Standardbacken, Bedienschlüssel

- cylindrical mounting D25 with clamping flat
- with diamond-coated rollers for an excellent grip, minimizing the damage risk for the clamped material
- any diameter is infinitely adjustable by means of a scale
- large clamping range from 1-70 mm, fast resetting of clamping range
- light-weight aluminium body, blue anodized
- scope of delivery: bar puller including 1 pair of jaws with diamond-coated rollers, 1 pair of fixed standard jaws, setting tools

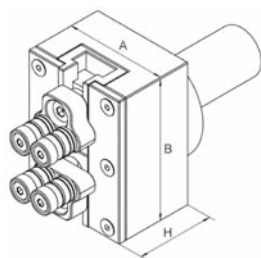

Aufnahme / Mount	Spannbereich / Clamping range	A mm	B mm	H mm	Art.-Nr. / Order no.
Zyl. / cyl. 25	1-70	55	75	42	47-SG25-70
Adapter Zyl. 25 auf VDI 30 / Adapter cyl. 25 to VDI 30					47-SG25-70-A30

N

Kurzbohrfutter VDI

Universal drill chucks VDI

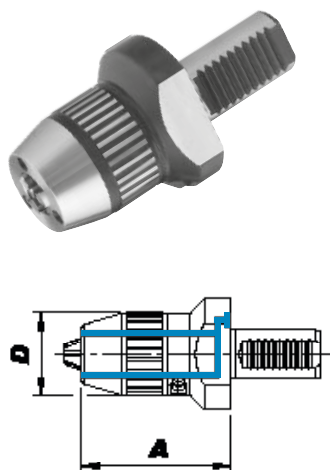

DIN 69880 (VDI) - mit Kühlmitteldüsen
DIN 69880 (VDI) - with coolant nozzles



VDI	Spannweite / Capacity mm	A mm	D mm	Art.-Nr. / Order no.
25	1-13	87	50	✘ 82-341325
30	1-13	87	50	● 82-341330
30	1-16	92	55	● 82-341630
40	1-13	88	50	● 82-341340
40	1-16	93	55	● 82-341640
50	1-16	101,5	55	● 82-341650

Mitlaufende Zentrierspitze mit VDI-Schaft

Revolving tailstock centres with VDI shank

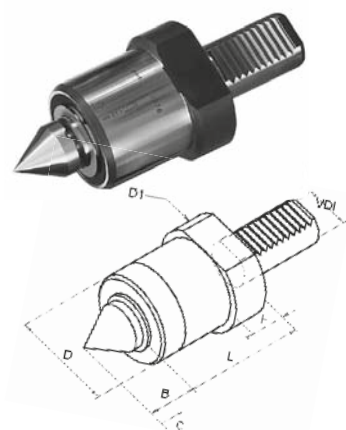

Gefedert
Spring-loaded

- speziell für den Einsatz auf CNC-Drehmaschinen
- für auswechselbare Einsätze
- Lieferung mit 1 Standardeinsatz (Fig. 1)
- especially for the use on CNC lathes
- for interchangeable inserts
- delivered with 1 standard insert (Fig. 1)

VDI	D mm	D1 mm	L mm	H mm	B mm	Federweg / Travelstroke max.	Art.-Nr. / Order no.
30	58	68	78	20	34	2,5	● 47-MZ2-30
40	58	83	80	22	34	2,5	● 47-MZ2-40

Einsätze
Inserts



Abb. / Fig.	E mm	B mm	G mm	Art.-Nr. / Order no.
1	28	34	-	▶ 47-MZ2-E1
2	28	40	7	▶ 47-MZ2-E2
2	28	40	12	▶ 47-MZ2-E3
3	58	36	25	▶ 47-MZ2-E4



Pendelhalter mit VDI-Schaft Floating chucks with VDI shank

Pendelhalter mit Innenkühlung Floating chucks with internal cooling

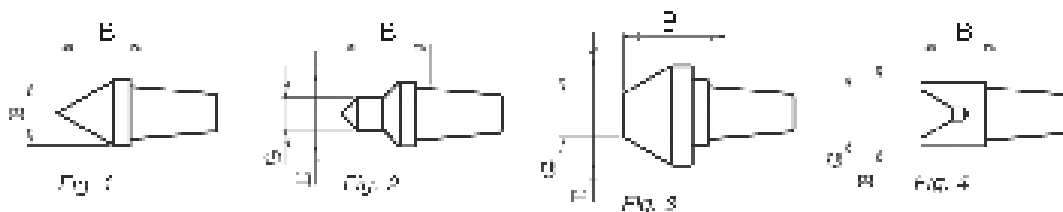
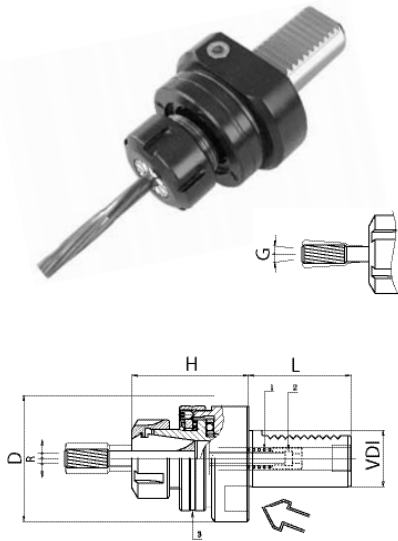

- mit einstellbarem Radialspiel
- Einstellbereiche: Freipendeln und Parallelpendeln
- Federkraft, Zentrierkraft und Freipendeln einstellbar
- radial clearance adjustable
- application: free and parallel floating
- spring force, centering force and floating adjustable

VDI	Spannzange / Collet	D mm	H mm	L mm	R max mm	G max mm	Art.-Nr. / Order no.
30	ER 25	68	64	55	1	1,5	47-PH-30-25
30	ER 32	68	72	55	1,5	1,5	47-PH-30-32
40	ER 32	83	74	63	1,5	1,5	47-PH-40-32
40	ER 40	83	74	63	1,5	1,5	47-PH-40-40

Räumwerkzeughalter mit VDI-Schaft Broach tool holders with VDI shank

Räumwerkzeughalter Broach tool holders

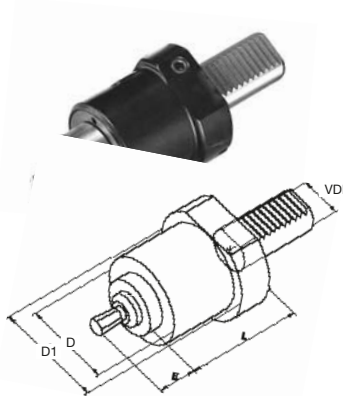

VDI	D mm	D1 mm	L mm	H mm	Aufnahme / Mounting	Art.-Nr. / Order no.
30	58	68	83	25	Ø 12	47-RHV-30-12
30	58	68	83	40	Ø 16	47-RHV-30-16
40	58	83	83	25	Ø 12	47-RHV-40-12
40	58	83	83	40	Ø 16	47-RHV-40-16

Räumstempel Broaching cutters

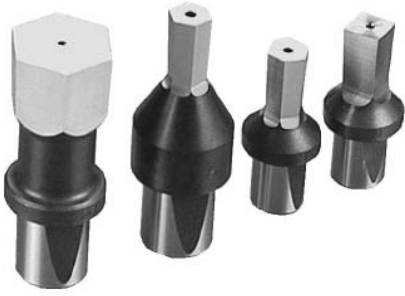

Räumstempel passend zu Aufnahme-Ø 12 Broaching cutters fitting to mounting-Ø 12

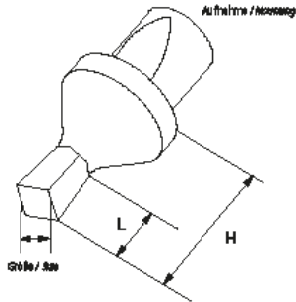

Form / Form	Größe / Size	H mm	L mm	Art.-Nr. / Order no.
Vierkant / Square	3	25	5	▶ 47-RST12/4-3,0
Vierkant / Square	4	25	6,5	▶ 47-RST12/4-4,0
Vierkant / Square	5	25	8,5	▶ 47-RST12/4-5,0
Vierkant / Square	5,5	25	9,5	▶ 47-RST12/4-5,5
Vierkant / Square	6	25	10,5	▶ 47-RST12/4-6,0
Vierkant / Square	7	25	13	▶ 47-RST12/4-7,0
Vierkant / Square	8	25	15,5	▶ 47-RST12/4-8,0
Vierkant / Square	9	25	21	▶ 47-RST12/4-9,0
Vierkant / Square	10	25	21	▶ 47-RST12/4-10,0
Vierkant / Square	11	25	21	▶ 47-RST12/4-11,0
Vierkant / Square	12	25	21	▶ 47-RST12/4-12,0
Vierkant / Square	13	25	21	▶ 47-RST12/4-13,0

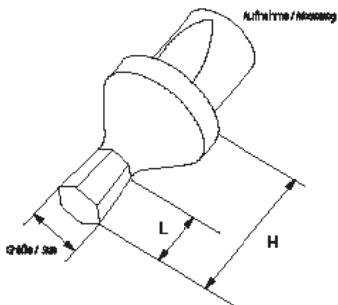

Form / Form	Größe / Size	H mm	L mm	Art.-Nr. / Order no.
Sechskant / Hexagon	1,5	25	3	▶ 47-RST12/6-1,5
Sechskant / Hexagon	2	25	3,5	▶ 47-RST12/6-2,0
Sechskant / Hexagon	2,5	25	4	▶ 47-RST12/6-2,5
Sechskant / Hexagon	3	25	5	▶ 47-RST12/6-3,0
Sechskant / Hexagon	3,5	25	6	▶ 47-RST12/6-3,5
Sechskant / Hexagon	4	25	6,5	▶ 47-RST12/6-4,0
Sechskant / Hexagon	5	25	8,5	▶ 47-RST12/6-5,0
Sechskant / Hexagon	5,5	25	9,5	▶ 47-RST12/6-5,5
Sechskant / Hexagon	6	25	10,5	▶ 47-RST12/6-6,0
Sechskant / Hexagon	7	25	13	▶ 47-RST12/6-7,0
Sechskant / Hexagon	8	25	15,5	▶ 47-RST12/6-8,0
Sechskant / Hexagon	9	25	21	▶ 47-RST12/6-9,0
Sechskant / Hexagon	10	25	21	▶ 47-RST12/6-10,0
Sechskant / Hexagon	11	25	21	▶ 47-RST12/6-11,0
Sechskant / Hexagon	12	25	21	▶ 47-RST12/6-12,0
Sechskant / Hexagon	13	25	21	▶ 47-RST12/6-13,0
Sechskant / Hexagon	14	25	21	▶ 47-RST12/6-14,0

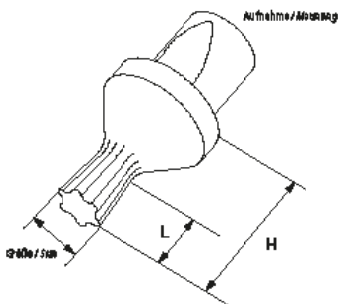

Form / Form	Größe / Size	H mm	Art.-Nr. / Order no.
Torx / Torx	6	25	▶ 47-RST12/T-6,0
Torx / Torx	8	25	▶ 47-RST12/T-8,0
Torx / Torx	10	25	▶ 47-RST12/T-10,0
Torx / Torx	15	25	▶ 47-RST12/T-15,0
Torx / Torx	20	25	▶ 47-RST12/T-20,0
Torx / Torx	25	25	▶ 47-RST12/T-25,0
Torx / Torx	27	25	▶ 47-RST12/T-27,0
Torx / Torx	30	25	▶ 47-RST12/T-30,0
Torx / Torx	40	25	▶ 47-RST12/T-40,0
Torx / Torx	45	25	▶ 47-RST12/T-45,0
Torx / Torx	50	25	▶ 47-RST12/T-50,0



Räumstempel Broaching cutters



Räumstempel passend zu Aufnahme-Ø 16 Broaching cutters fitting to mounting-Ø 16

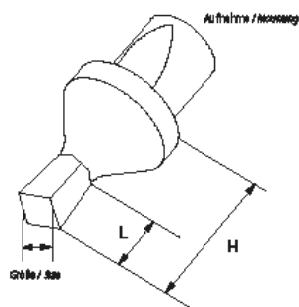

Form / Form	Größe / Size	H mm	L mm	Art.-Nr. / Order no.
Vierkant / Square	3	40	5	▶ 47-RST16/4-3,0
Vierkant / Square	4	40	6,5	▶ 47-RST16/4-4,0
Vierkant / Square	5	40	8,5	▶ 47-RST16/4-5,0
Vierkant / Square	6	40	10,5	▶ 47-RST16/4-6,0
Vierkant / Square	7	40	13	▶ 47-RST16/4-7,0
Vierkant / Square	8	40	15,5	▶ 47-RST16/4-8,0
Vierkant / Square	9	40	17,5	▶ 47-RST16/4-9,0
Vierkant / Square	10	40	18,5	▶ 47-RST16/4-10,0
Vierkant / Square	11	40	20	▶ 47-RST16/4-11,0
Vierkant / Square	12	40	20	▶ 47-RST16/4-12,0
Vierkant / Square	13	40	28	▶ 47-RST16/4-13,0
Vierkant / Square	14	40	32	▶ 47-RST16/4-14,0
Vierkant / Square	15	40	32	▶ 47-RST16/4-15,0
Vierkant / Square	16	40	32	▶ 47-RST16/4-16,0
Vierkant / Square	17	40	32	▶ 47-RST16/4-17,0
Vierkant / Square	18	40	32	▶ 47-RST16/4-18,0
Vierkant / Square	19	40	32	▶ 47-RST16/4-19,0
Vierkant / Square	20	40	32	▶ 47-RST16/4-20,0

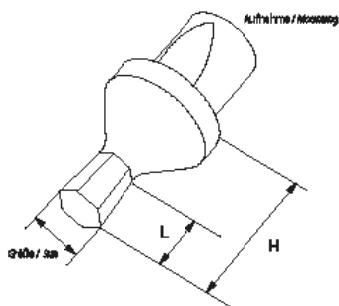

Form / Form	Größe / Size	H mm	L mm	Art.-Nr. / Order no.
Sechskant / Hexagon	3	40	5	▶ 47-RST16/6-3,0
Sechskant / Hexagon	3,5	40	6	▶ 47-RST16/6-3,5
Sechskant / Hexagon	4	40	6,5	▶ 47-RST16/6-4,0
Sechskant / Hexagon	5	40	8,5	▶ 47-RST16/6-5,0
Sechskant / Hexagon	6	40	10,5	▶ 47-RST16/6-6,0
Sechskant / Hexagon	7	40	13	▶ 47-RST16/6-7,0
Sechskant / Hexagon	8	40	15,5	▶ 47-RST16/6-8,0
Sechskant / Hexagon	9	40	17,5	▶ 47-RST16/6-9,0
Sechskant / Hexagon	10	40	18,5	▶ 47-RST16/6-10,0
Sechskant / Hexagon	11	40	20	▶ 47-RST16/6-11,0
Sechskant / Hexagon	12	40	20	▶ 47-RST16/6-12,0
Sechskant / Hexagon	13	40	28	▶ 47-RST16/6-13,0
Sechskant / Hexagon	14	40	32	▶ 47-RST16/6-14,0
Sechskant / Hexagon	15	40	32	▶ 47-RST16/6-15,0
Sechskant / Hexagon	16	40	32	▶ 47-RST16/6-16,0
Sechskant / Hexagon	17	40	32	▶ 47-RST16/6-17,0
Sechskant / Hexagon	18	40	32	▶ 47-RST16/6-18,0
Sechskant / Hexagon	19	40	32	▶ 47-RST16/6-19,0
Sechskant / Hexagon	20	40	32	▶ 47-RST16/6-20,0
Sechskant / Hexagon	21	40	32	▶ 47-RST16/6-21,0
Sechskant / Hexagon	22	40	32	▶ 47-RST16/6-22,0
Sechskant / Hexagon	23	40	32	▶ 47-RST16/6-23,0
Sechskant / Hexagon	24	40	32	▶ 47-RST16/6-24,0
Sechskant / Hexagon	25	40	32	▶ 47-RST16/6-25,0



Räumstempel Broaching cutters



Räumstempel passend zu Aufnahme-Ø 16
Broaching cutters fitting to mounting-Ø 16

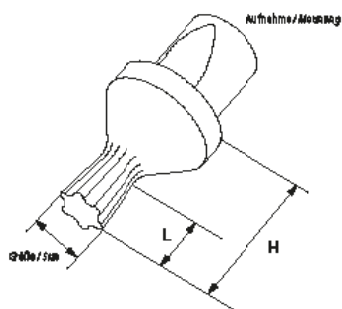

Form / Form	Größe / Size	H mm	Art.-Nr. / Order no.
Torx / Torx	6	40	▶ 47-RST16/T-10,0
Torx / Torx	8	40	▶ 47-RST16/T-15,0
Torx / Torx	10	40	▶ 47-RST16/T-20,0
Torx / Torx	15	40	▶ 47-RST16/T-25,0
Torx / Torx	20	40	▶ 47-RST16/T-27,0
Torx / Torx	25	40	▶ 47-RST16/T-30,0
Torx / Torx	27	40	▶ 47-RST16/T-40,0
Torx / Torx	30	40	▶ 47-RST16/T-45,0
Torx / Torx	40	40	▶ 47-RST16/T-50,0
Torx / Torx	45	40	▶ 47-RST16/T-55,0
Torx / Torx	50	40	▶ 47-RST16/T-60,0

Werkstückanschlag mit VDI-Schaft Work piece stops with VDI shank

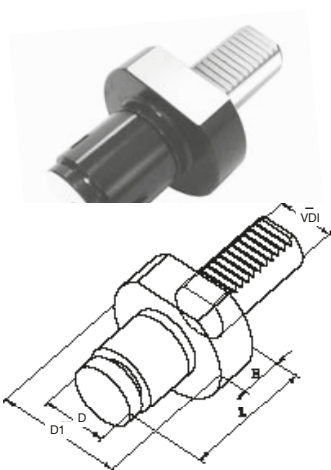

Mitlaufende Werkstückanschläge Revolving work piece stops

- gefedert

- spring-loaded

VDI	D mm	D1 mm	L mm	H mm	Federweg / Stroke mm	Art.-Nr. / Order no.
20	35	50	58	16	3	47-MW-2035
20	56	50	58	16	3	47-MW-2056
30	35	68	70	20	3	47-MW-3035
30	56	68	70	20	3	47-MW-3056
40	44	83	78	22	3	47-MW-4044
40	60	83	78	22	3	47-MW-4060

Prüfdorne Test arbors

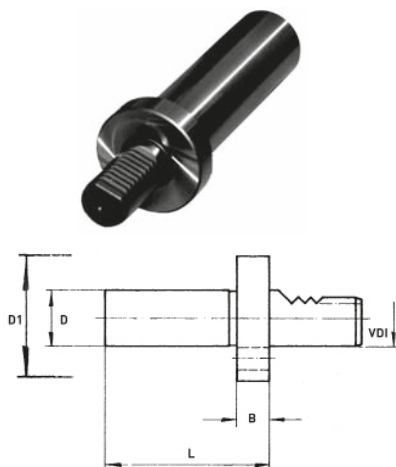

Prüfdorne - DIN 69880 (VDI) Test arbors - DIN 69880 (VDI)



VDI	D mm	D1 mm	L mm	B mm	Art.-Nr. / Order no.
16	30	40	120	15	83-PD-16-30
20	40	50	150	15	83-PD-20-40
25	40	58	150	15	83-PD-25-40
30	40	68	200	15	83-PD-30-40
40	40	83	200	15	83-PD-40-40
50	40	98	200	15	83-PD-50-40

Einrichtehalter Setting holders

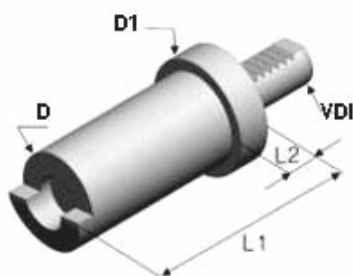

Einrichtehalter Setting holders

VDI	D mm	D1 mm	L1 mm	L2 mm	Art.-Nr. / Order no.
16	30	40	100	15	47-EH-16
20	40	50	100	15	47-EH-20
25	40	58	100	15	47-EH-25
30	40	68	100	15	47-EH-30
40	40	83	100	15	47-EH-40
50	40	98	100	15	47-EH-50
60	40	123	100	15	47-EH-60



Zubehör für VDI-Halter Accessories for VDI-tool holders

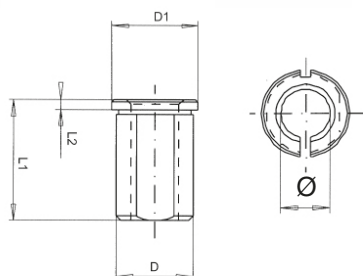

Reduzierbuchsen RZ, geschlitzt Reduction sleeves RZ, slotted

D mm	Ø mm	D1 mm	L1 mm	L2 mm	Art.-Nr. / Order no.
20	8, 10, 12, 14, 16	24	50	4	47-RZ-20-Ø
25	8, 10, 12, 14, 16, 18, 20	29	50	4	47-RZ-25-Ø
32	8, 10, 12, 14, 16, 18, 20, 25	36	60	4	47-RZ-32-Ø
40	10, 12, 14, 16, 18, 20, 25, 32	44	75	4	47-RZ-40-Ø
50	20, 25, 32, 40	54	75	4	47-RZ-50-Ø
60	25, 32, 40, 50	64	75	4	47-RZ-60-Ø

Reduzierbuchsen für Bohrstangenhalter Typ E2 Reduction sleeves for boring bar holders type E2

- Reduzierung zum Spannen von Werkzeugen mit Zylinderschaft
- reduction sleeve for clamping of tools with cylindrical shank

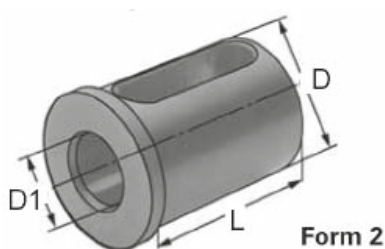
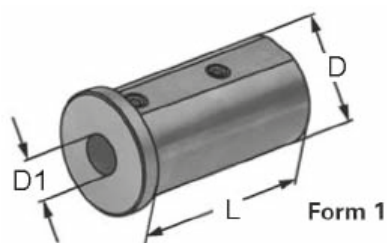

D mm	D1 mm	L mm	Form / Form	Art.-Nr. / Order no.
25	6	46	1	47-KRH-25-06
25	8	46	1	47-KRH-25-08
25	10	46	1	47-KRH-25-10
25	12	46	1	47-KRH-25-12
25	16	46	2	47-KRH-25-16
25	20	46	2	47-KRH-25-20
32	6	56	1	47-KRH-32-06
32	8	56	1	47-KRH-32-08
32	10	56	1	47-KRH-32-10
32	12	56	1	47-KRH-32-12
32	16	56	2	47-KRH-32-16
32	20	56	2	47-KRH-32-20
32	25	56	2	47-KRH-32-25
40	6	71	1	47-KRH-40-06
40	8	71	1	47-KRH-40-08
40	10	71	1	47-KRH-40-10
40	12	71	1	47-KRH-40-12
40	16	71	2	47-KRH-40-16
40	20	71	2	47-KRH-40-20
40	25	71	2	47-KRH-40-25
40	32	71	2	47-KRH-40-32

Kugelspritzdüsen Ball spray nozzles

- Material: Messing
- material: brass

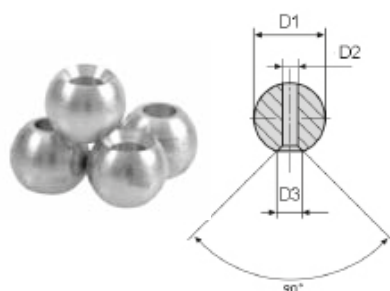

D mm	D1 mm	D2 mm	VE / Set	Art.-Nr. / Order no.
8	3,5	5,5	10 Stk. / 10 pcs.	47-KD-8
10	5	7	10 Stk. / 10 pcs.	47-KD-10
14	6	9	10 Stk. / 10 pcs.	47-KD-14

Abgabe nur in VE à 10 Stück, Preis versteht sich für 10 Stück
Only available in sets of 10 pieces, price refers to 10 pieces

Zubehör für VDI-Halter Accessories for VDI-tool holders

O-Ringe (VE à 10 Stück) O-rings (sets of 10 pieces)



Für / For	Art.-Nr. / Order no.
VDI 16	47-OR-VDI16
VDI 20	47-OR-VDI20
VDI 25	47-OR-VDI25
VDI 30	47-OR-VDI30
VDI 40	47-OR-VDI40
VDI 50	47-OR-VDI50
VDI 60	47-OR-VDI60

Der Preis versteht sich für 10 Stück.
The price refers to 10 pieces.

Schutzstopfen Protective plugs



Schutzstopfen Z2, Stahl Protective plug Z2, steel

VDI	D mm	B mm	Art.-Nr. / Order no.
16	40	13	47-Z2-16S
20	50	16	47-Z2-20S
25	58	16	47-Z2-25S
30	68	16	47-Z2-30S
40	83	20	47-Z2-40S
50	98	20	47-Z2-50S
60	123	20	47-Z2-60S

Schutzstopfen Z2, Kunststoff Protective plug Z2, plastic



VDI	D mm	B mm	Art.-Nr. / Order no.
16	40	13	47-Z2-16K
20	50	16	47-Z2-20K
25	58	16	47-Z2-25K
30	68	16	47-Z2-30K
40	83	20	47-Z2-40K
50	98	20	47-Z2-50K
60	123	20	47-Z2-60K

Angetriebene Werkzeuge

Driven tools

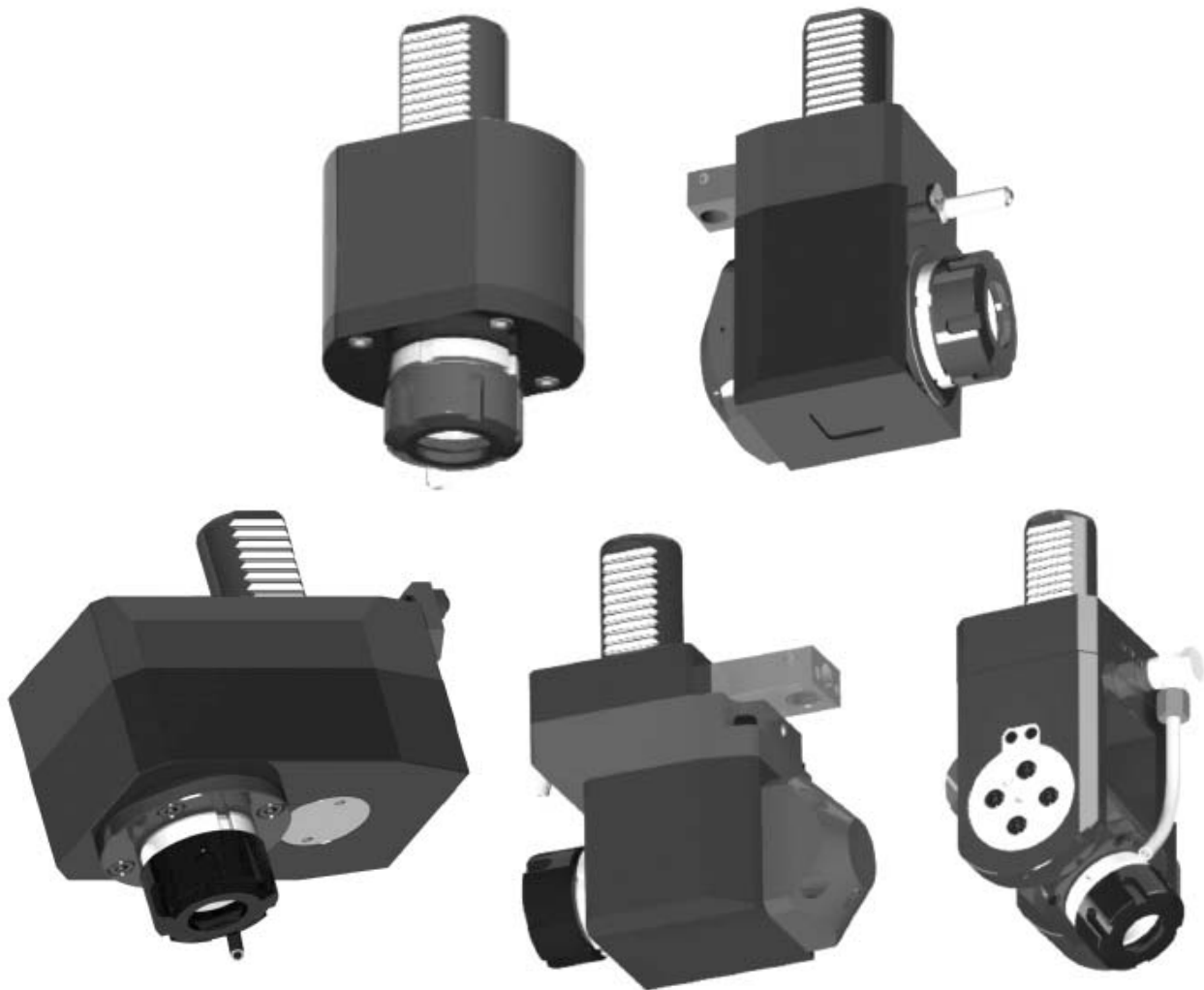

■ Inhalt:

- | DIN 5480 - für SAUTER Revolver
- | DIN 5482 - für SAUTER Revolver
- | TOEM - für BARRUFALDI Revolver
- | Befestigung mit Schrauben -
für MORI SEIKI Revolver
- | Befestigung mit Schrauben -
für NAKAMURA Revolver

■ Content:

- | DIN 5480 - for SAUTER turrets
- | DIN 5482 - for SAUTER turrets
- | TOEM - for BARRUFALDI turrets
- | Mounted by bolts -
for MORI SEIKI turrets
- | Mounted by bolts -
for NAKAMURA turrets

Angetriebene Werkzeuge - DIN 5480 - für SAUTER Revolver

Driven tools - DIN 5480 - for SAUTER turrets



Angetriebene Werkzeuge - DIN 5480

Driven tools - DIN 5480

- Kühlmitteldruck bis 20 bar
- gekapselte Präzisionslager
- geeignet für hohe Drehzahlen
- geeignet für Rechts- und Linkslauf
- coolant pressure up to 20 bar
- high-precision capsulated bearings
- suitable for high spindle speeds
- suitable for right and left-hand rotation



DIN 5480, gerade

DIN 5480, straight

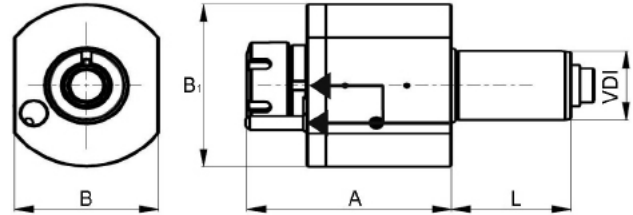

VDI	SZ / Collet	IK / IC	A mm	L mm	B mm	B1 mm	Übersetzung / Ratio	Max. Drehmoment / Max. torque Nm	Drehzahl / Speed min-1	Art.-Nr. / Order no.
30	ER 25	-	87	55	62	69	1 : 1	28	6000	▶ 47-80-G-30-25
30	ER 25	✓	87	55	62	69	1 : 1	28	6000	▶ 47-80-G-30-25IK
40	ER 25	-	120	63	76	94	1 : 1	50	6000	▶ 47-80-G-40-25
40	ER 25	✓	120	63	76	94	1 : 1	50	6000	▶ 47-80-G-40-25IK
40	ER 32	-	120	63	76	94	1 : 1	50	6000	▶ 47-80-G-40-32
40	ER 32	✓	120	63	76	94	1 : 1	50	6000	▶ 47-80-G-40-32IK



DIN 5480, abgewinkelt 90°

DIN 5480, angular 90°

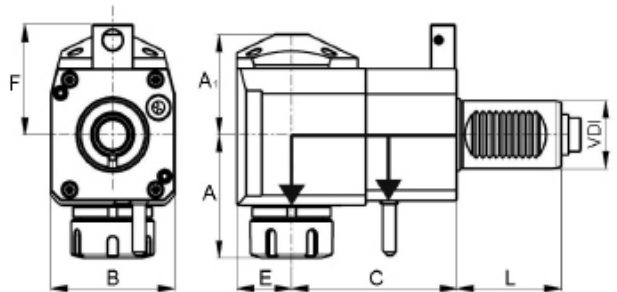

VDI	SZ / Collet	IK / IC	Richtung / Direction	C mm	A1 mm	A mm	L mm	F mm	E mm	B mm	Übersetzung / Ratio	Max. Drehmoment / Max. torque Nm	Drehzahl / Speed min-1	Art.-Nr. / Order no.
30	ER 25	-	rechts/right	55	48	63	55	56	26	64	1 : 1	28	6000	▶ 47-80-WKR-30-25
30	ER 25	✓	rechts/right	55	51	63	55	56	26	64	1 : 1	28	6000	▶ 47-80-WKR-30-25IK
30	ER 25	-	rechts/right	85	48	63	55	56	26	64	1 : 1	28	6000	▶ 47-80-WR-30-25
30	ER 25	✓	rechts/right	85	51	63	55	56	26	64	1 : 1	28	6000	▶ 47-80-WR-30-25IK
40	ER 32	-	rechts/right	80	59	74	63	65	33	75	1 : 1	50	6000	▶ 47-80-WKR-40-32
40	ER 32	✓	rechts/right	80	62	74	63	65	33	75	1 : 1	50	6000	▶ 47-80-WKR-40-32IK
40	ER 32	-	rechts/right	100	59	74	63	65	33	75	1 : 1	50	6000	▶ 47-80-WR-40-32
40	ER 32	✓	rechts/right	100	62	74	63	65	33	75	1 : 1	50	6000	▶ 47-80-WR-40-32IK

Angetriebene Werkzeuge mit VDI 50 auf Anfrage lieferbar
Driven tools with VDI 50 available upon request

Passende Sicherheitsschlüssel ER siehe Seite 263 / Suitable safety-spanners ER see page 263

Angetriebene Werkzeuge - DIN 5480 - für SAUTER Revolver

Driven tools - DIN 5480 - for SAUTER turrets



DIN 5480
gerade, versetzt
DIN 5480
straight, offset

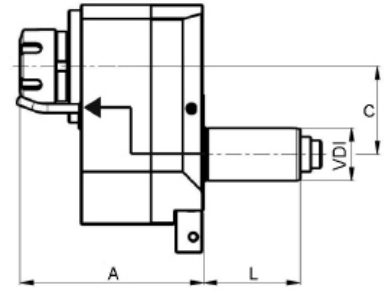
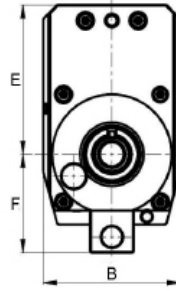

VDI	SZ / Collet	IK / IC	Richtung / Direction	C mm	A mm	L mm	F mm	E mm	B mm	Übersetzung / Ratio	Max. Drehmoment / Max. torque Nm	Drehzahl / Speed min-1	Art.-Nr. / Order no.
30	ER 25	-	rechts/right	50	105	55	56	85	78	1 : 2	14	12000	47-80-GV-30-25



DIN 5480
abgewinkelt 90°,
zurückgesetzt
DIN 5480
angular 90°,
offset

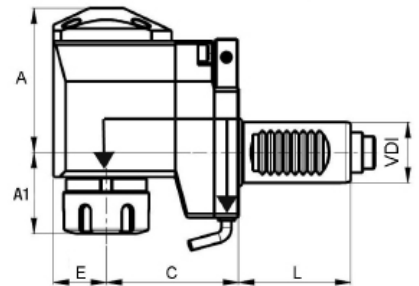
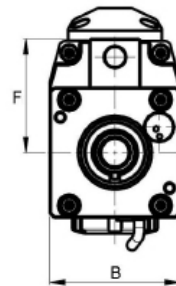

VDI	SZ / Collet	IK / IC	Richtung / Direction	C mm	A mm	A1 mm	L mm	F mm	E mm	B mm	Übersetzung / Ratio	Max. Drehmoment / Max. torque Nm	Drehzahl / Speed min-1	Art.-Nr. / Order no.
30	ER 25	-	rechts/right	75	71	40	55	56	26	64	1 : 1	28	6000	47-80-WVR-30-25
30	ER 25	✓	rechts/right	75	74	40	55	56	26	64	1 : 1	28	6000	47-80-WVR-30-25IK



DIN 5480,
verstellbar 0° bis ±105°
DIN 5480,
adjustable 0° to ±105°

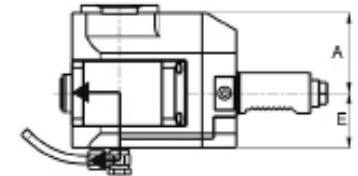
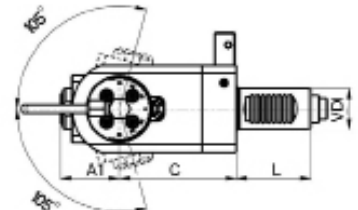
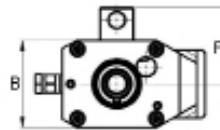

VDI	SZ / Collet	IK / IC	C mm	A mm	A1 mm	L mm	F mm	E mm	B mm	Übersetzung / Ratio	Max. Drehmoment / Max. torque Nm	Drehzahl / Speed min-1	Art.-Nr. / Order no.
30	ER 16	✓	86	65	43	55	56	40	64	1 : 1	16	6000	47-80-E-30-16IK

Angetriebene Werkzeuge mit VDI 50 auf Anfrage lieferbar
Driven tools with VDI 50 available upon request

Passende Sicherheitsschlüssel ER siehe Seite 263 / Suitable safety-spanners ER see page 263

Angetriebene Werkzeuge - DIN 5482 - für SAUTER Revolver

Driven tools - DIN 5482- for SAUTER turrets



Angetriebene Werkzeuge - DIN 5482

Driven tools - DIN 5482

- Kühlmitteldruck bis 20 bar
- gekapselte Präzisionslager
- geeignet für hohe Drehzahlen
- geeignet für Rechts- und Linkslauf
- coolant pressure up to 20 bar
- high-precision capsulated bearings
- suitable for high spindle speeds
- suitable for right and left-hand rotation



DIN 5482, gerade

DIN 5482, straight

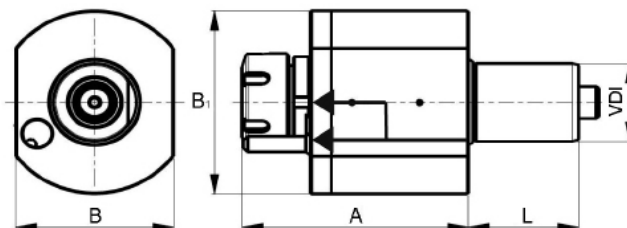

VDI	SZ / Collet	IK / IC	A mm	L mm	B mm	B1 mm	Übersetzung / Ratio	Max. Drehmoment / Max. torque Nm	Drehzahl / Speed min-1	Art.-Nr. / Order no.
30	ER 25	-	87	45	62	69	1 : 1	28	6000	▶ 47-82-G-30-25
30	ER 25	✓	87	45	62	69	1 : 1	28	6000	▶ 47-82-G-30-25IK
40	ER 25	-	105	53	76	94	1 : 1	50	6000	▶ 47-82-G-40-25
40	ER 25	✓	105	53	76	94	1 : 1	50	6000	▶ 47-82-G-40-25IK
40	ER 32	-	108	53	76	94	1 : 1	50	6000	▶ 47-82-G-40-32
40	ER 32	✓	108	53	76	94	1 : 1	50	6000	▶ 47-82-G-40-32IK

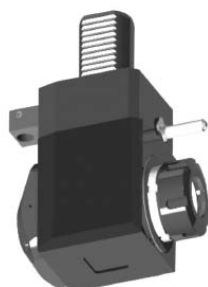

DIN 5482, abgewinkelt 90°

DIN 5482, angular 90°

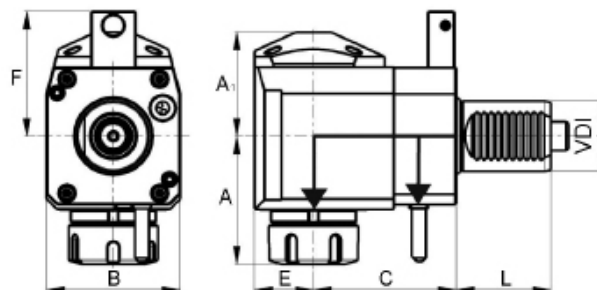

VDI	SZ / Collet	IK / IC	Richtung / Direction	C mm	A1 mm	A mm	L mm	F mm	E mm	B mm	Übersetzung / Ratio	Max. Drehmoment / Max. torque Nm	Drehzahl / Speed min-1	Art.-Nr. / Order no.
30	ER 25	-	rechts/right	55	48	63	45	48	26	64	1 : 1	28	6000	▶ 47-82-WR-30-25
30	ER 25	✓	rechts/right	55	51	63	45	48	26	64	1 : 1	28	6000	▶ 47-82-WR-30-25IK
40	ER 25	-	rechts/right	80	59	70	53	71	33	75	1 : 1	50	6000	▶ 47-82-WR-40-25
40	ER 25	✓	rechts/right	80	62	70	53	71	33	75	1 : 1	50	6000	▶ 47-82-WR-40-25IK
40	ER 32	-	rechts/right	80	59	74	53	71	33	75	1 : 1	50	6000	▶ 47-82-WR-40-32
40	ER 32	✓	rechts/right	80	62	74	53	71	33	75	1 : 1	50	6000	▶ 47-82-WR-40-32IK
40	ER 25	-	links/left	80	59	70	53	71	33	75	1 : 1	50	6000	▶ 47-82-WL-40-25
40	ER 25	✓	links/left	80	62	70	53	71	33	75	1 : 1	50	6000	▶ 47-82-WL-40-25IK
40	ER 32	-	links/left	80	59	74	53	71	33	75	1 : 1	50	6000	▶ 47-82-WL-40-32
40	ER 32	✓	links/left	80	62	74	53	71	33	75	1 : 1	50	6000	▶ 47-82-WL-40-32IK

Angetriebene Werkzeuge mit VDI 50 auf Anfrage lieferbar
Driven tools with VDI 50 available upon request

Passende Sicherheitsschlüssel ER siehe Seite 263 / Suitable safety spanners ER see page 263

Angetriebene Werkzeuge - DIN 5482 - für SAUTER Revolver

Driven tools - DIN 5482- for SAUTER turrets



DIN 5482
gerade, versetzt
DIN 5482
straight, offset

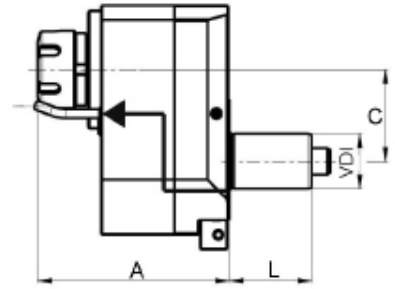
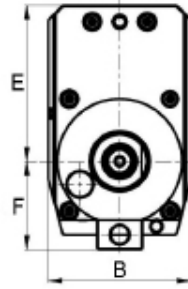

VDI	SZ / Collet	IK / IC	Richtung / Direction	C mm	A mm	L mm	F mm	E mm	B mm	Übersetzung / Ratio	Max. Drehmoment / Max. torque Nm	Drehzahl / Speed min-1	Art.-Nr. / Order no.
30	ER 25	-	rechts/right	50	105	45	48	85	78	1 : 2	14	12000	47-82-GV-30-25



DIN 5482
abgewinkelt 90°,
zurückgesetzt
DIN 5482
angular 90°,
offset

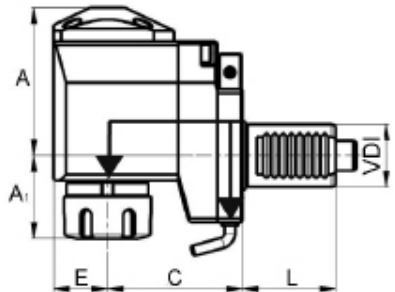
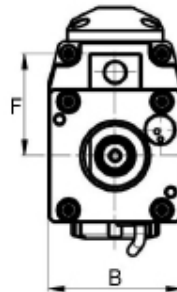

VDI	SZ / Collet	IK / IC	Richtung / Direction	C mm	A mm	A1 mm	L mm	F mm	E mm	B mm	Übersetzung / Ratio	Max. Drehmoment / Max. torque Nm	Drehzahl / Speed min-1	Art.-Nr. / Order no.
30	ER 25	-	rechts/right	75	71	40	45	48	26	64	1 : 1	28	6000	47-82-WVR-30-25
30	ER 25	✓	rechts/right	75	74	40	45	48	26	64	1 : 1	28	6000	47-82-WVR-30-25IK



DIN 5482,
verstellbar 0° bis ±105°
DIN 5482,
adjustable 0° to ±105°

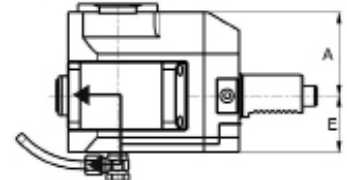
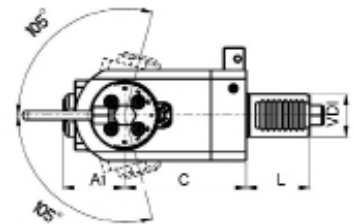
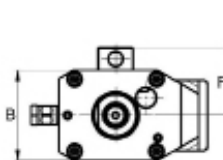

VDI	SZ / Collet	IK / IC	C mm	A mm	A1 mm	L mm	F mm	E mm	B mm	Übersetzung / Ratio	Max. Drehmoment / Max. torque Nm	Drehzahl / Speed min-1	Art.-Nr. / Order no.
30	ER 16	✓	86	65	43	45	48	40	64	1 : 1	16	6000	47-82-E-30-16IK

Angetriebene Werkzeuge mit VDI 50 auf Anfrage lieferbar
Driven tools with VDI 50 available upon request

Passende Sicherheitsschlüssel ER siehe Seite 263 / Suitable safety spanners ER see page 263

Angetriebene Werkzeuge - TOEM - für BARRUFALDI Revolver

Driven tools - TOEM - for BARRUFALDI turrets



Angetriebene Werkzeuge - TOEM

Driven tools - TOEM

- Kühlmitteldruck bis 20 bar
- gekapselte Präzisionslager
- geeignet für hohe Drehzahlen
- geeignet für Rechts- und Linkslauf
- coolant pressure up to 20 bar
- high-precision capsulated bearings
- suitable for high spindle speeds
- suitable for right and left-hand rotation



TOEM, gerade

TOEM, straight

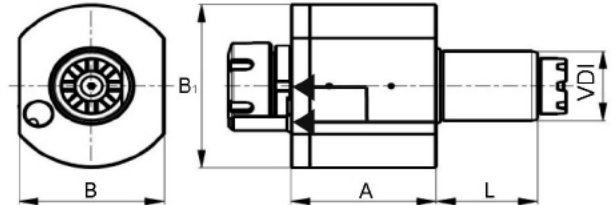

VDI	SZ / Collet	IK / IC	A mm	L mm	B mm	B1 mm	Übersetzung / Ratio	Max. Drehmoment / Max. torque Nm	Drehzahl / Speed min-1	Art.-Nr. / Order no.
30	ER 25	-	87	45	62	69	1 : 1	28	6000	▶ 47-TO-G-30-25
30	ER 25	✓	87	45	62	69	1 : 1	28	6000	▶ 47-TO-G-30-25IK
40	ER 25	-	105	53	76	94	1 : 1	50	6000	▶ 47-TO-G-40-25
40	ER 25	✓	105	53	76	94	1 : 1	50	6000	▶ 47-TO-G-40-25IK
40	ER 32	-	108	53	76	94	1 : 1	50	6000	▶ 47-TO-G-40-32
40	ER 32	✓	108	53	76	94	1 : 1	50	6000	▶ 47-TO-G-40-32IK

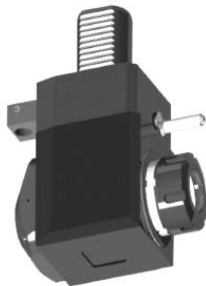

TOEM, abgewinkelt 90°

TOEM, angular 90°

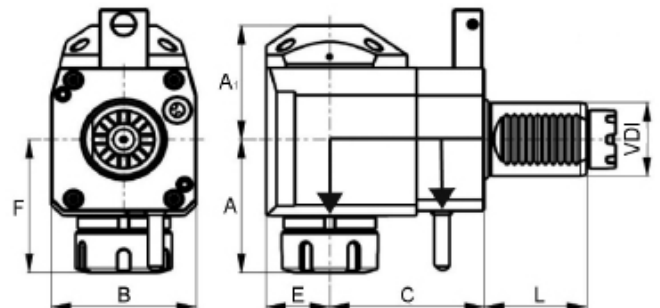

VDI	SZ / Collet	IK / IC	Richtung / Direction	C mm	A1 mm	A mm	L mm	F mm	E mm	B mm	Übersetzung / Ratio	Max. Drehmoment / Max. torque Nm	Drehzahl / Speed min-1	Art.-Nr. / Order no.
30	ER 25	-	rechts/right	55	48	63	45	48	26	64	1 : 1	28	6000	▶ 47-TO-WR-30-25
30	ER 25	✓	rechts/right	55	51	63	45	48	26	64	1 : 1	28	6000	▶ 47-TO-WR-30-25IK

Angetriebene Werkzeuge mit VDI 50 auf Anfrage lieferbar
Driven tools with VDI 50 available upon request

Passende Sicherheitsschlüssel ER siehe Seite 263 / Suitable safety-spanners ER see page 263

Angetriebene Werkzeuge - Befestigung mit Schrauben

- für MORI SEIKI Revolver

Driven tools - Mounted by bolts - for MORI SEIKI turrets

Angetriebene Werkzeuge - Befestigung mit Schrauben

Driven tools - Mounted by bolts

- Kühlmitteldruck bis 20 bar
- gekapselte Präzisionslager
- geeignet für hohe Drehzahlen
- geeignet für Rechts- und Linkslauf
- coolant pressure up to 20 bar
- high-precision capsulated bearings
- suitable for high spindle speeds
- suitable for right and left-hand rotation



Gerade
Straight

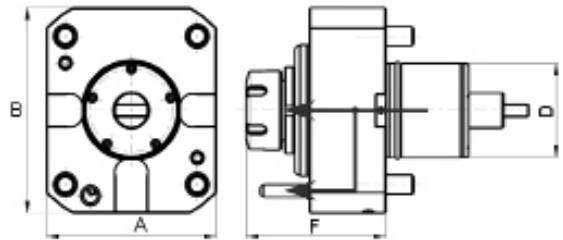

D mm	SZ / Collet	IK / IC	F mm	A mm	B mm	Überset- zung / Ratio	Max. Drehmoment / Max. torque Nm	Drehzahl / Speed min-1	Art.-Nr. / Order no.
60	ER 32	-	89	108	130	1 : 1	70	6000	▶ 47-MO-G-60-32
60	ER 32	✓	89	108	130	1 : 1	70	6000	▶ 47-MO-G-60-32IK

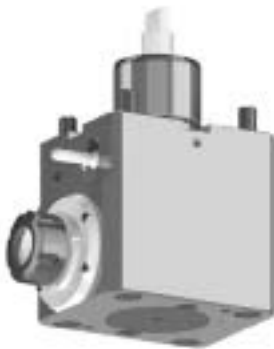

Abgewinkelt 90°
Angular 90°

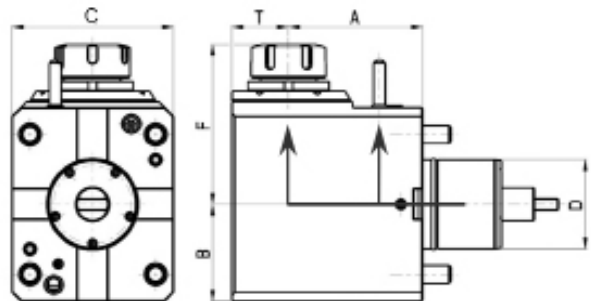

D mm	SZ / Collet	IK / IC	A mm	B mm	F mm	T mm	C mm	Überset- zung / Ratio	Max. Drehmoment / Max. torque Nm	Drehzahl / Speed min-1	Art.-Nr. / Order no.
60	ER 32	-	90	65	107	38	108	1 : 1	70	6000	▶ 47-MO-WR-60-32
60	ER 32	✓	90	65	107	38	108	1 : 1	70	6000	▶ 47-MO-WR-60-32IK

Angetriebene Werkzeuge mit VDI 50 auf Anfrage lieferbar
Driven tools with VDI 50 available upon request

Passende Sicherheitsschlüssel ER siehe Seite 263 / Suitable safety-spanners ER see page 263



Angetriebene Werkzeuge - Befestigung mit Schrauben

- für NAKAMURA Revolver

Driven tools - Mounted by bolts - for NAKAMURA turrets

Angetriebene Werkzeuge - Befestigung mit Schrauben

Driven tools - Mounted by bolts

- Kühlmitteldruck bis 20 bar
- gekapselte Präzisionslager
- geeignet für hohe Drehzahlen
- geeignet für Rechts- und Linkslauf
- coolant pressure up to 20 bar
- high-precision capsulated bearings
- suitable for high spindle speeds
- suitable for right and left-hand rotation

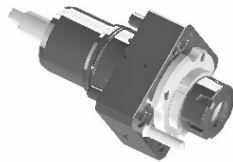

**Gerade
Straight**

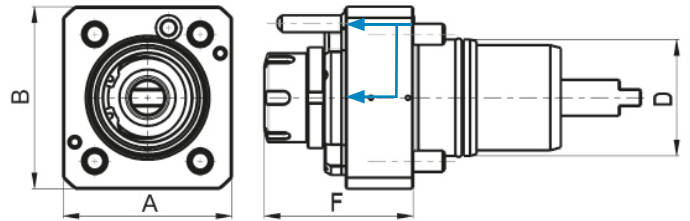

D mm	SZ / Collet	IK / IC	F mm	A mm	B mm	Übersetzung / Ratio	Max. Drehmoment / Max. torque Nm	Drehzahl / Speed min-1	Art.-Nr. / Order no.
55	ER 25	-	71	80	86	1 : 1	28	6000	▶ 47-NA-G-55-25
55	ER 25	✓	71	80	86	1 : 1	28	6000	▶ 47-NA-G-55-25IK
65	ER 32	-	75	96	96	1 : 1	50	6000	▶ 47-NA-G-65-32
65	ER 32	✓	75	96	96	1 : 1	50	6000	▶ 47-NA-G-65-32IK

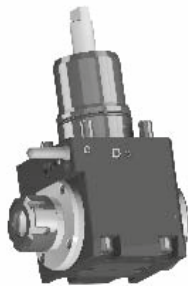

**Abgewinkelt 90°
Angular 90°**

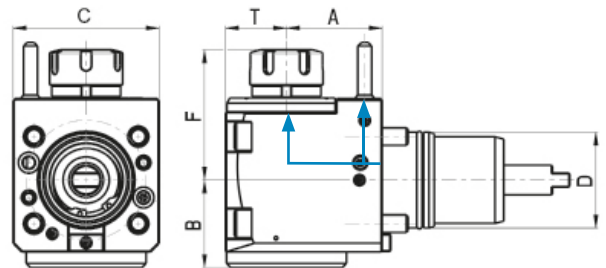

D mm	SZ / Collet	IK / IC	A mm	B mm	F mm	T mm	C mm	Übersetzung / Ratio	Max. Drehmoment / Max. torque Nm	Drehzahl / Speed min-1	Art.-Nr. / Order no.
55	ER 25	-	55	50,3	74,8	35	84	1 : 1	28	6000	▶ 47-NA-WR-55-25
55	ER 25	✓	55	50,3	74,8	35	84	1 : 1	28	6000	▶ 47-NA-WR-55-25IK
65	ER 32	-	65	59	110	38	96	1 : 1	50	6000	▶ 47-NA-WR-65-32
65	ER 32	✓	65	59	110	38	96	1 : 1	50	6000	▶ 47-NA-WR-65-32IK

Angetriebene Werkzeuge mit VDI 50 auf Anfrage lieferbar
Driven tools with VDI 50 available upon request

Passende Sicherheitsschlüssel ER siehe Seite 263 / Suitable safety-spanners ER see page 263



Spannzangen

Collets



■ Inhalt:

- | DIN 6388B / OZ (doppelt geschlitzt)
- | DIN 6388A / OZ (einfach geschlitzt)
- | DIN 6499 / ER / ESX (ER 8 - ER 50)
- | DIN 6499 / ER / ESX, Präzisionsausführung (ER 8 - ER 40)
- | DIN 6499 / ER / ESX, abgedichtet (ER 11 - ER 40)
- | Gewindebohrzangen mit Innenvierkant (ER 16 - ER 50)
- | Gewindebohrzangen mit Längenausgleich
- | Spannzangen Erickson, Typ DK
- | Typ 385 E (5C), Typ 369 E (R8)
- | Direktspannzangen
- | DIN 6343 (161 E, 163 E, 173 E, 185 E, 193 E)
- | Spannköpfe
- | Spannzangensätze
- | Anschlagschrauben
- | Aluminiumkoffer

■ Content:

- | *DIN 6388B / OZ (double slotted)*
- | *DIN 6388A / OZ (single slotted)*
- | *DIN 6499 / ER / ESX (ER 8 - ER 50)*
- | *DIN 6499 / ER / ESX, precision design (ER 8 - ER 40)*
- | *DIN 6499 / ER / ESX, sealed (ER 11 - ER 40)*
- | *Tapping collets with internal square (ER 16 - ER 50)*
- | *Tapping collets with length compensation*
- | *Collet Erickson, Type DK*
- | *Type 385 E (5C), type 369 E (R8)*
- | *Taper collets*
- | *DIN 6343 (161 E, 163 E, 173 E, 185 E, 193 E)*
- | *Clamping heads*
- | *Collet sets*
- | *Stop screws*
- | *Aluminium cases*

Spannzangen OZ, DIN 6388B, doppelt geschlitzt
Collets OZ, DIN 6388B, double slotted

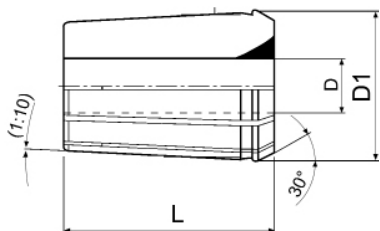

Typ 415 E (OZ 16), 0,5 mm steigend / stepped

D mm	D1 mm	L mm	Art.-Nr. / Order no.
2-16	25,5	40	06-415E-Ø

Typ 4541 E (OZ 20), 1 mm steigend / stepped

D mm	D1 mm	L mm	Art.-Nr. / Order no.
2-20	29,8	45	06-4541E-Ø

Typ 462 E (OZ 25), 0,5 mm steigend / stepped

D mm	D1 mm	L mm	Art.-Nr. / Order no.
2-25	35,5	52	06-462E-Ø

Typ 467 E (OZ 32), 0,5 mm steigend / stepped

D mm	D1 mm	L mm	Art.-Nr. / Order no.
3-32	43,7	60	06-467E-Ø

Typ 468 E (OZ 40), 1 mm steigend / stepped

D mm	D1 mm	L mm	Art.-Nr. / Order no.
12-40	52,2	68	06-468E-Ø

Spannzangen OZ, DIN 6388A, einfach geschlitzt
Collets OZ, DIN 6388A, single slotted



Typ 401 E (OZ 8), 0,5 mm steigend / stepped

D mm	D1 mm	L mm	Art.-Nr. / Order no.
1,0-2,5	14,5	26	06-401E-Ø
3,0-8,0	14,5	26	06-401E-Ø

Typ 410 E (OZ 16), 1 mm steigend / stepped

D mm	D1 mm	L mm	Art.-Nr. / Order no.
2-16	25,5	40	06-410E-Ø

Typ 444 E (OZ 25), 1 mm steigend / stepped

D mm	D1 mm	L mm	Art.-Nr. / Order no.
2-25	35,5	52	06-444E-Ø

Typ 450 E (OZ 32), 1 mm steigend / stepped

D mm	D1 mm	L mm	Art.-Nr. / Order no.
4-32	44	60	06-450E-Ø

- Lagerstandard / in stock
- ▶ innerhalb weniger Tage / within a few days
- auf Anfrage / on request
- * auslaufende Größe / as stock lasts



Spannzangen ER/ESX, DIN 6499

Collets ER/ESX, DIN 6499

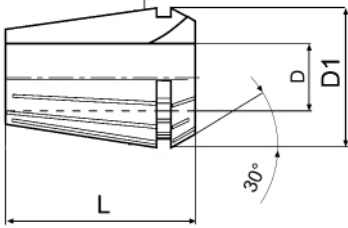

ER 8 (4004 E), 0,5 mm steigend / stepped

D mm	D1 mm	L mm	Art.-Nr. / Order no.
1-5	8,5	13,5	09-9008-Ø

ER 11 (4008 E), 0,5 mm steigend / stepped

D mm	D1 mm	L mm	Art.-Nr. / Order no.
1-7	11,5	18	09-9011-Ø

ER 16 (426 E), 0,5 mm steigend / stepped

D mm	D1 mm	L mm	Art.-Nr. / Order no.
1-10	17	27,5	09-9016-Ø

ER 20 (428 E), 0,5 mm steigend / stepped

D mm	D1 mm	L mm	Art.-Nr. / Order no.
1-2,5	21	31,5	09-9020-Ø
3-13	21	31,5	09-9020-Ø

ER 25 (430 E), 0,5 mm steigend / stepped

D mm	D1 mm	L mm	Art.-Nr. / Order no.
1-2,5	26	34	09-9025-Ø
3-16	26	34	09-9025-Ø

ER 32 (470 E), 0,5 mm steigend / stepped

D mm	D1 mm	L mm	Art.-Nr. / Order no.
1-2,5	33	40	09-9032-Ø
3-20	33	40	09-9032-Ø

ER 40 (472 E), 1 mm steigend / stepped

D mm	D1 mm	L mm	Art.-Nr. / Order no.
3-26	41	46	09-9040-Ø
27-30	41	46	09-9040-Ø

ER 50 (477 E), 1 mm steigend / stepped

D mm	D1 mm	L mm	Art.-Nr. / Order no.
6-34	52	60	09-9050-Ø



Präzisionsausführung, Spannzangen ER/ESX, DIN 6499

Precision design, collets ER/ESX, DIN 6499

D min. mm	D max. mm	Prüflänge	Rundlauf / Runout
1	1,5	6	0,010
2	3	10	0,008
3,5	7	16	0,008
7,5	10	25	0,008
10,5	18	40	0,010
18,5	26	50	0,010

ER 8 (4004 E) - Präzision / precision, 0,5 mm steigend / stepped

D mm	D1 mm	L mm	Art.-Nr. / Order no.
1-2,5	8,5	13,5	● 09-9008-ØUP
3-5	8,5	13,5	● 09-9008-ØUP

ER 11 (4008 E) - Präzision / precision, 0,5 mm steigend / stepped

D mm	D1 mm	L mm	Art.-Nr. / Order no.
1-2,5	11,5	18	● 09-9011-ØUP
3-7	11,5	18	● 09-9011-ØUP

ER 16 (426 E) - Präzision / precision, 0,5 mm steigend / stepped

D mm	D1 mm	L mm	Art.-Nr. / Order no.
1-2,5	17	27,5	● 09-9016-ØUP
3-10	17	27,5	● 09-9016-ØUP

ER 20 (428 E) - Präzision / precision, 1 mm steigend / stepped

D mm	D1 mm	L mm	Art.-Nr. / Order no.
1-2	21	31,5	● 09-9020-ØUP
3-13	21	31,5	● 09-9020-ØUP

ER 25 (430 E) - Präzision / precision, 1 mm steigend / stepped

D mm	D1 mm	L mm	Art.-Nr. / Order no.
1-2	26	34	● 09-9025-ØUP
3-16	26	34	● 09-9025-ØUP

ER 32 (470 E) - Präzision / precision, 1 mm steigend / stepped

D mm	D1 mm	L mm	Art.-Nr. / Order no.
2	33	40	● 09-9032-2,0UP
3-20	33	40	● 09-9032-ØUP

ER 40 (472 E) - Präzision / precision, 1 mm steigend / stepped

D mm	D1 mm	L mm	Art.-Nr. / Order no.
3-26	41	46	● 09-9040-ØUP

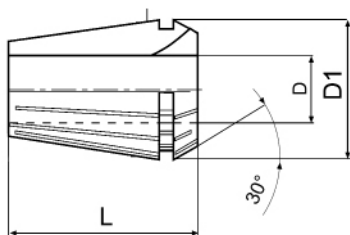

**PRÄZISION /
PRECISION**

Spannzangen abgedichtet ER/ESX, DIN 6499, 1 mm steigend
Sealed collets ER/ESX, DIN 6499, 1 mm stepped

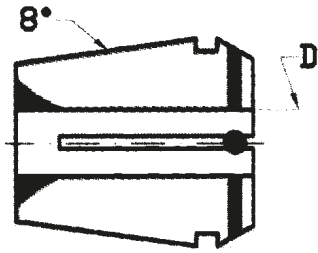

**ABGEDICHTET /
SEALED**

ER 11 (4012 E) - abgedichtet / sealed

D mm	Art.-Nr. / Order no.
3 - 7 mm	09-9011-ØS

ER 16 (425 E) - abgedichtet / sealed

D mm	Art.-Nr. / Order no.
3 - 10 mm	09-9016-ØS

ER 20 (427 E) - abgedichtet / sealed

D mm	Art.-Nr. / Order no.
3 - 13 mm	09-9020-ØS

ER 25 (429 E) - abgedichtet / sealed

D mm	Art.-Nr. / Order no.
3 - 16 mm	09-9025-ØS

ER 32 (469 E) - abgedichtet / sealed

D mm	Art.-Nr. / Order no.
3 - 20 mm	09-9032-ØS

ER 40 (471 E) - abgedichtet / sealed

D mm	Art.-Nr. / Order no.
4 - 26 mm	09-9040-ØS



Gewindebohrzangen mit Innenvierkant

Tapping collets with internal square

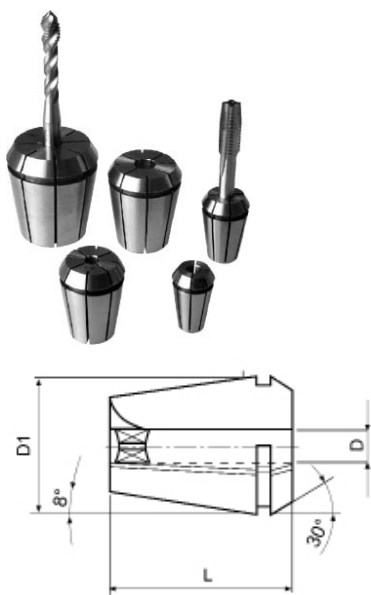

ER 16-GB mit Innenvierkant

ER 16-GB with internal square

D x □ mm	D1 mm	L mm	Art.-Nr. / Order no.
3,5 x 2,7	16	27,5	● 09-8016-3,5
4 x 3	16	27,5	● 09-8016-4,0
4,5 x 3,4	16	27,5	● 09-8016-4,5
5 x 5	16	27,5	● 09-8016-5,0
5,5 x 4,3	16	27,5	● 09-8016-5,5
6 x 4,9	16	27,5	● 09-8016-6,0
7 x 5,5	16	27,5	● 09-8016-7,0
8 x 6,2	16	27,5	● 09-8016-8,0
9 x 7	16	27,5	● 09-8016-9,0

ER 20-GB mit Innenvierkant

ER 20-GB with internal square

D x □ mm	D1 mm	L mm	Art.-Nr. / Order no.
3,5 x 2,7	20	31,5	● 09-8020-3,5
4 x 3	20	31,5	● 09-8020-4,0
4,5 x 3,4	20	31,5	● 09-8020-4,5
5 x 5	20	31,5	● 09-8020-5,0
5,5 x 4,3	20	31,5	● 09-8020-5,5
6 x 4,9	20	31,5	● 09-8020-6,0
7 x 5,5	20	31,5	● 09-8020-7,0
8 x 6,2	20	31,5	● 09-8020-8,0
9 x 7	20	31,5	● 09-8020-9,0
10 x 8	20	31,5	● 09-8020-10,0
11 x 9	20	31,5	● 09-8020-11,0
12 x 9	20	31,5	● 09-8020-12,0

ER 25-GB mit Innenvierkant

ER 25-GB with internal square

D x □ mm	D1 mm	L mm	Art.-Nr. / Order no.
3,5 x 2,7	25	34	● 09-8025-3,5
4 x 3	25	34	● 09-8025-4,0
4,5 x 3,4	25	34	● 09-8025-4,5
5 x 5	25	34	● 09-8025-5,0
5,5 x 4,3	25	34	● 09-8025-5,5
6 x 4,9	25	34	● 09-8025-6,0
7 x 5,5	25	34	● 09-8025-7,0
8 x 6,2	25	34	● 09-8025-8,0
9 x 7	25	34	● 09-8025-9,0
10 x 8	25	34	● 09-8025-10,0
11 x 9	25	34	● 09-8025-11,0
12 x 9	25	34	● 09-8025-12,0
14 x 11	25	34	● 09-8025-14,0
16 x 12	25	34	● 09-8025-16,0

Gewindebohrzangen mit Innenvierkant

Tapping collets with internal square

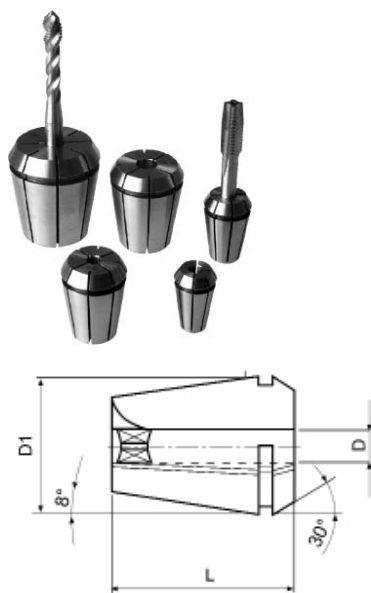

ER 32-GB mit Innenvierkant

ER 32-GB with internal square

D x □ mm	D1 mm	L mm	Art.-Nr. / Order no.
3,5 x 2,7	32	40	● 09-8032-3,5
4 x 3	32	40	● 09-8032-4,0
4,5 x 3,4	32	40	● 09-8032-4,5
5 x 5	32	40	● 09-8032-5,0
5,5 x 4,3	32	40	● 09-8032-5,5
6 x 4,9	32	40	● 09-8032-6,0
7 x 5,5	32	40	● 09-8032-7,0
8 x 6,2	32	40	● 09-8032-8,0
9 x 7	32	40	● 09-8032-9,0
10 x 8	32	40	● 09-8032-10,0
11 x 9	32	40	● 09-8032-11,0
12 x 9	32	40	● 09-8032-12,0
14 x 11	32	40	● 09-8032-14,0
16 x 12	32	40	● 09-8032-16,0
18 x 14,5	32	40	● 09-8032-18,0
20 x 16	32	40	● 09-8032-20,0

ER 40-GB mit Innenvierkant

ER 40-GB with internal square

D x □ mm	D1 mm	L mm	Art.-Nr. / Order no.
6 x 4,9	40	46	● 09-8040-6,0
7 x 5,5	40	46	● 09-8040-7,0
8 x 6,2	40	46	● 09-8040-8,0
9 x 7	40	46	● 09-8040-9,0
10 x 8	40	46	● 09-8040-10,0
11 x 9	40	46	● 09-8040-11,0
12 x 9	40	46	● 09-8040-12,0
14 x 11	40	46	● 09-8040-14,0
16 x 12	40	46	● 09-8040-16,0
18 x 14,5	40	46	● 09-8040-18,0
20 x 16	40	46	● 09-8040-20,0
22 x 18	40	46	● 09-8040-22,0

ER 50-GB mit Innenvierkant

ER 50-GB with internal square

D x □ mm	D1 mm	L mm	Art.-Nr. / Order no.
8 x 6,2	50	60	* 09-8050-8,0
9 x 7	50	60	* 09-8050-9,0
10 x 8	50	60	* 09-8050-10,0
11 x 9	50	60	* 09-8050-11,0
12 x 9	50	60	* 09-8050-12,0
14 x 11	50	60	* 09-8050-14,0
16 x 12	50	60	* 09-8050-16,0
18 x 14,5	50	60	* 09-8050-18,0
20 x 16	50	60	* 09-8050-20,0
22 x 18	50	60	* 09-8050-22,0
25 x 20	50	60	* 09-8050-25,0
28 x 22	50	60	* 09-8050-28,0
32 x 24	50	60	* 09-8050-32,0

Gewindebohrzangen mit Längenausgleich

Tapping collets with length compensation

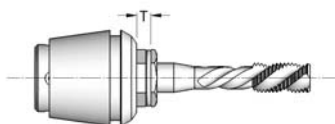
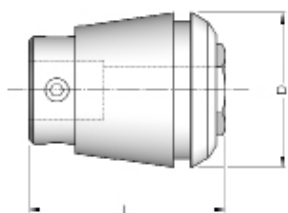

Gewindebohrzangen ER mit Längenausgleich

Tapping collets ER with length compensation

SZ / Collet	Spann-Ø / Clamping-Ø mm	D mm	L mm	T mm	Art.-Nr. / Order no.
ER 16	Ø 2,5 - Ø 6,0	17	27	7	● 09-6016-Ø
ER 20	Ø 2,8 - Ø 7,0	21	31	7	● 09-6020-Ø
ER 25	Ø 2,5 - Ø 10,0	26	34	8	● 09-6025-Ø
ER 32	Ø 4,5 - Ø 12,0	33	43	10	● 09-6032-Ø
ER 40	Ø 6,0 - Ø 16,0	41	54	13	● 09-6040-Ø

SZ / Collet	Standard-Ø / Standard-Ø mm
ER 16	2,5 / 2,8 / 3,5 / 4,5 / 6,0
ER 20	2,8 / 3,5 / 4,5 / 6,0 / 7,0
ER 25	2,5 / 2,8 / 3,5 / 4,5 / 6,0 / 7,0 / 8,0 / 9,0 / 10,0
ER 32	4,5 / 6,0 / 7,0 / 8,0 / 9,0 / 10,0 / 11,0 / 12,0
ER 40	6,0 / 7,0 / 8,0 / 9,0 / 10,0 / 11,0 / 12,0 / 14,0 / 16,0

Andere Abmessungen lieferbar auf Anfrage
Further dimensions available upon request

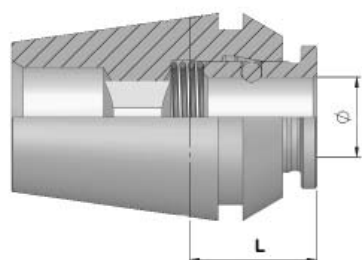

Gewindebohrzangen ER ohne Längenausgleich, mit Schnellwechselsystem

Tapping collets ER without length compensation, with quick-change system

SZ / Collet	Spann-Ø / Clamping-Ø mm	D mm	L mm	Art.-Nr. / Order no.
ER 16	Ø 3,5 - Ø 6,0	17	11	● 09-5016-Ø
ER 20	Ø 3,5 - Ø 7,0	21	17	● 09-5020-Ø
ER 25	Ø 3,5 - Ø 10,0	26	18,5	● 09-5025-Ø
ER 32	Ø 4,5 - Ø 12,0	33	18,5	● 09-5032-Ø
ER 40	Ø 6,0 - Ø 16,0	41	19	● 09-5040-Ø

SZ / Collet	Standard-Ø / Standard-Ø mm
ER 16	3,5 / 4,5 / 6,0
ER 20	3,5 / 4,5 / 6,0 / 7,0
ER 25	3,5 / 4,5 / 6,0 / 7,0 / 8,0 / 9,0 / 10,0
ER 32	4,5 / 6,0 / 7,0 / 8,0 / 9,0 / 10,0 / 11,0 / 12,0
ER 40	6,0 / 7,0 / 8,0 / 9,0 / 10,0 / 11,0 / 12,0 / 14,0 / 16,0

Andere Abmessungen lieferbar auf Anfrage
Further dimensions available upon request

Spannzangen Typ Erickson Collets type Erickson



Typ 412 E (DK-S), 0,25 mm steigend / stepped

D mm	D1 mm	L mm	Art.-Nr. / Order no.
1-2	6,8	16,3	▶ 06-412E-Ø
2,25-3	6,8	16,3	▶ 06-412E-Ø
3,25-4	6,8	16,3	▶ 06-412E-Ø

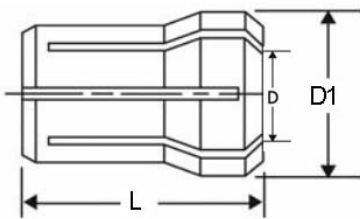

Typ 416 E (DK30), 0,5 mm steigend / stepped

D mm	D1 mm	L mm	Art.-Nr. / Order no.
1-2,5	9,5	25,4	▶ 06-416E-Ø
3-6,5	9,5	25,4	▶ 06-416E-Ø

Typ 417 E (DK20), 0,5 mm steigend / stepped

D mm	D1 mm	L mm	Art.-Nr. / Order no.
1-2,5	13,6	30,3	▶ 06-417E-Ø
3-10	13,6	30,3	▶ 06-417E-Ø

Typ 418 E (DK10), 0,5 mm steigend / stepped

D mm	D1 mm	L mm	Art.-Nr. / Order no.
1-2,5	19,4	36,7	▶ 06-418E-Ø
3-14,5	19,4	36,7	▶ 06-418E-Ø



Sonstige Spannzangen, rund Collets, round

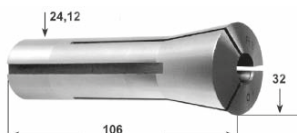
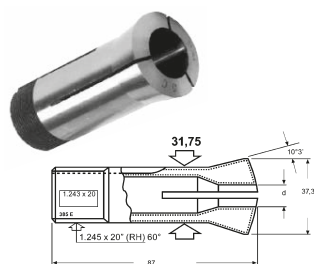

Typ 385 E (5C), 0,5 mm steigend / 0,5 mm stepped

D mm	Art.-Nr. / Order no.
1 - 2,5 mm	● 06-385E-Ø
3 - 27 mm	● 06-385E-Ø
27,5 - 30 mm	● 06-385E-Ø

Typ 369 E (R8), 1 mm steigend / 1 mm stepped

D mm	Art.-Nr. / Order no.
2 mm	● 06-369E-Ø
3 - 22 mm	● 06-369E-Ø

Direktspannzangen Taper collets



Mit Morsekegel With morse taper

MK / MT	Ø mm	Innengewinde / Internal thread	Art.-Nr. / Order no.
2	2, 3, 4, 5, 6, 8, 10, 12	M10	● 06-228-2-Ø
3	3, 4, 5, 6, 8, 10, 12, 14, 16, 18	M12	● 06-228-3-Ø
4	3, 4, 5, 6, 8, 10, 12, 14, 16, 18, 20, 22, 24, 25	M16	● 06-228-4-Ø



Typ 574 E mit Steilkegel Type 574 E with steep taper

SK	Ø mm	Gewinde / Thread	Art.-Nr. / Order no.
40	4, 5, 6, 8, 10, 12, 14, 16, 18, 20, 22, 24, 25	S20 x 2	● 06-DSSK-S20-Ø



Typ 575 E mit Steilkegel Type 575 E with steep taper

SK	Ø mm	Gewinde / Thread	Art.-Nr. / Order no.
40	4, 5, 6, 8, 10, 12, 14, 16, 18, 20, 22, 24, 25	M16	● 06-DSSK-M16-Ø

Spannzangen DIN 6343 Collets DIN 6343

Typ 161 E, 0,5 mm steigend / 0,5 mm stepped

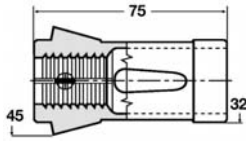

D mm	Form / form	Art.-Nr. / Order no.
3-26 mm	rund / round	06-161E-Ø

Bis einschließlich Ø 8 mm - glatte Bohrung, ab Ø 8,5 mit Querrillen
Up to Ø 8 mm - smooth bore, from Ø 8,5 mm - radial grooved

Typ 163 E, 0,5 mm steigend / 0,5 mm stepped

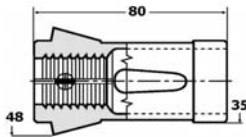

D mm	Form / form	Art.-Nr. / Order no.
3-30 mm	rund / round	06-163E-Ø

Bis einschließlich Ø 8 mm - glatte Bohrung, ab Ø 8,5 mit Querrillen
Up to Ø 8 mm - smooth bore, from Ø 8,5 mm - radial grooved

Typ 173 E, 1 mm steigend / 1 mm stepped

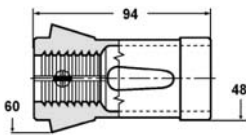

Größe / Size	Form / form	Art.-Nr. / Order no.
Ø 3 - 42 mm	rund / round	06-173E-Ø
□ 4 - 30 mm	vierkant / square	06-173E-Ø-4Kant
⊕ 4 - 36 mm	sechskant / hexagonal	06-173E-Ø-6Kant
Nofallspannzange / Emergency collet 173 E		06-173E-NOT

Bis einschließlich Ø 8 mm - glatte Bohrung, ab Ø 8,5 mit Querrillen
Up to Ø 8 mm - smooth bore, from Ø 8,5 mm - radial grooved

Typ 185 E, 1 mm steigend / 1 mm stepped

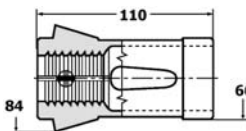

Größe / Size	Form / form	Art.-Nr. / Order no.
Ø 4 - 60 mm	rund / round	06-185E-Ø
□ 10 - 40 mm	vierkant / square	06-185E-Ø-4Kant
⊕ 6 - 50 mm	sechskant / hexagonal	06-185E-Ø-6Kant
Nofallspannzange / Emergency collet 185 E		06-185E-NOT

Bis einschließlich Ø 8 mm - glatte Bohrung, ab Ø 8,5 mit Querrillen
Up to Ø 8 mm - smooth bore, from Ø 8,5 mm - radial grooved

Typ 193 E, 5 mm steigend / 5 mm stepped

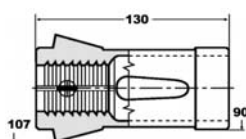

D mm	Form / form	Art.-Nr. / Order no.
20 - 80	rund / round	06-193E-Ø

Weitere Größen auf Anfrage
Further sizes available upon request



Spannköpfe Clamping heads



Größe 42, rund, glatt Size 42, round, smooth

Spanndurchmesser / Clamping diameter mm	Steigung / Pitch mm	Art.-Nr. / Order no.
3 - 42	0,5	▶ 36-42RD-Ø



Größe 42, rund, quengerillt Size 42, round, radial grooves

Spanndurchmesser / Clamping diameter mm	Steigung / Pitch mm	Art.-Nr. / Order no.
8 - 42	0,5	▶ 36-42RD-ØQ



Größe 42, rund, längs- und quengerillt Size 42, round, radial and axial grooves

Spanndurchmesser / Clamping diameter mm	Steigung / Pitch mm	Art.-Nr. / Order no.
11 - 42	0,5	▶ 36-42RD-ØLQ

Größe 42, sechskant, glatt Size 42, hexagonal, smooth

Spanndurchmesser / Clamping diameter mm	Steigung / Pitch mm	Art.-Nr. / Order no.
7 - 38	1	▶ 36-42SK-Ø

Größe 42, sechskant, quengerillt Size 42, hexagonal, radial grooves

Spanndurchmesser / Clamping diameter mm	Steigung / Pitch mm	Art.-Nr. / Order no.
8 - 38	1	▶ 36-42SK-ØQ



Spannköpfe Clamping heads



Größe 65, rund, glatt Size 65, round, smooth

Spanndurchmesser / Clamping diameter mm	Steigung / Pitch mm	Art.-Nr. / Order no.
4 - 65	0,5	▶ 36-65RD-Ø



Größe 65, rund, quengerillt Size 65, round, radial grooves

Spanndurchmesser / Clamping diameter mm	Steigung / Pitch mm	Art.-Nr. / Order no.
8 - 65	0,5	▶ 36-65RD-ØQ



Größe 65, rund, längs- und quengerillt Size 65, round, radial and axial grooves

Spanndurchmesser / Clamping diameter mm	Steigung / Pitch mm	Art.-Nr. / Order no.
11 - 65	0,5	▶ 36-65RD-ØLQ

Größe 65, sechskant, glatt Size 65, hexagonal, smooth

Spanndurchmesser / Clamping diameter mm	Steigung / Pitch mm	Art.-Nr. / Order no.
7 - 56	1	▶ 36-65SK-Ø

Größe 65, sechskant, quengerillt Size 65, hexagonal, radial grooves

Spanndurchmesser / Clamping diameter mm	Steigung / Pitch mm	Art.-Nr. / Order no.
8 - 56	1	▶ 36-65SK-ØQ



Spannzangen-Sätze, 1 mm steigend Collet sets, 1 mm stepped



Spannzangen-Sätze ER in Holzleiste DIN 6499 Collet sets ER in wooden tray DIN 6499

Typ / Type	D mm	Anzahl d. Spannzangen / Number of collets	Art.-Nr. / Order no.
ER 11 (4008E)*	1-7	13	● 09-SATZ-ER11HL
ER 16 (426E)	1-10	10	● 09-SATZ-ER16HL
ER 20 (428E)	2-13	12	● 09-SATZ-ER20HL
ER 25 (430E)	2-16	15	● 09-SATZ-ER25HL
ER 32 (470E)	3-20	18	● 09-SATZ-ER32HL
ER 40 (472E)	4-26	23	● 09-SATZ-ER40HL

* 0,5 mm steigend
* 0,5 mm stepped

Spannzangen-Sätze ER im Aluminiumkoffer DIN 6499 Collet sets ER in aluminium case DIN 6499



Typ / Type	D mm	Anzahl d. Spannzangen / Number of collets	Art.-Nr. / Order no.
ER 16 (426E)	1-10	10	● 09-SATZ-ER16AK
ER 20 (428E)	2-13	12	● 09-SATZ-ER20AK
ER 25 (430E)	2-16	15	● 09-SATZ-ER25AK
ER 32 (470E)	3-20	18	● 09-SATZ-ER32AK
ER 40 (472E)	4-26	23	● 09-SATZ-ER40AK

Präzisions-Spannzangen-Sätze ER in Holzleiste DIN 6499 Precision collet sets ER in wooden tray DIN 6499



- Präzisionsausführung

- precision type

Typ / Type	D mm	Anzahl d. Spannzangen / Number of collets	Art.-Nr. / Order no.
ER 11 (4008E)	1-7	7	● 09-SATZ-ER11-UP
ER 16 (426E)	1-10	10	● 09-SATZ-ER16-UP
ER 20 (428E)	2-13	12	● 09-SATZ-ER20-UP
ER 25 (430E)	2-16	15	● 09-SATZ-ER25-UP
ER 32 (470E)	3-20	18	● 09-SATZ-ER32-UP
ER 40 (472E)	4-26	23	● 09-SATZ-ER40-UP

Abgedichtete Spannzangen-Sätze ER in Holzleiste DIN 6499 Sealed collet sets ER in wooden tray DIN 6499



- abgedichtete Ausführung

- sealed type

Typ / Type	D mm	Anzahl d. Spannzangen / Number of collets	Art.-Nr. / Order no.
ER 11 (4012E)	3-7	5	● 09-SATZ-ER11-SD
ER 16 (425E)	3-10	8	● 09-SATZ-ER16-SD
ER 20 (427E)	3-13	11	● 09-SATZ-ER20-SD
ER 25 (429E)	3-16	14	● 09-SATZ-ER25-SD
ER 32 (469E)	3-20	18	● 09-SATZ-ER32-SD
ER 40 (471E)	4-26	23	● 09-SATZ-ER40-SD

Spannzangen-Sätze Collet sets



Spannzangen-Sätze OZ in Holzleiste DIN 6388 Collet sets OZ in wooden tray DIN 6388

Typ / Type	D mm	Anzahl d. Spannzangen / Number of collets	Art.-Nr. / Order no.
415 E	2-16	15	06-SATZ-415EHL
462 E	2-25	24	06-SATZ-462EHL
467 E	4-32	29	06-SATZ-467EHL
410 E	2-16	15	06-SATZ-410EHL
444 E	2-25	24	06-SATZ-444EHL



Spannzangen-Sätze OZ im Aluminiumkoffer DIN 6388 Collet sets OZ in aluminium case DIN 6388

Typ / Type	D mm	Anzahl d. Spannzangen / Number of collets	Art.-Nr. / Order no.
415 E	2-16	15	06-SATZ-415EAK
462 E	2-25	24	06-SATZ-462EAK
467 E	4-32	29	06-SATZ-467EAK
410 E	2-16	15	06-SATZ-410EAK
444 E	2-25	24	06-SATZ-444EAK



Sonstige Spannzangen Sätze Optional collet sets

Typ / Type	D mm	Steigung / Stepping	Holzleiste / wooden tray	Anzahl d. Spannzangen / Number of collets	Art.-Nr. / Order no.
385 E	3-26	1	Ja / Yes	24	06-SATZ-385EHL
385 E	1-29	0,5	Nein / No	57	06-SATZ-385E/0,5
173 E	3-42	1	Nein / No	40	06-SATZ-173E
173 E	3-42	0,5	Nein / No	79	06-SATZ-173E/0,5

Anschlagschrauben Stop screws



Für 5C-Spannzangen For 5C-collets

- Gewinde auf ganzer Länge gehärtet
- für einstellbare Werkstücktiefen bis 75 mm (von Spannzangenoberfläche)
- thread hardened over entire length
- for adjustable work piece depths up to 75 mm (from collet surface)

Spannzange /
Collet

Art.-Nr. /
Order no.

für 5C-Spannzangen / for 5C-collets

06-106220

Für Spannzangen DIN 6343 For collets DIN 6343

- für Spannzangen 173E, 185E
- for collets 173E, 185E

Spannzange /
Collet

Art.-Nr. /
Order no.

für 173E / for 173E

06-173E-AN

für 185E / for 185E

06-185E-AN





Für Spannzangen For collets

Passend für / Suitable for	Anzahl der Plätze / Number of seats	Art.-Nr. / Order no.
ER 16	10	● 09-ER16-AK
ER 20	13	● 09-ER20-AK
ER 25 / 410E / 415E	16	● 09-ER25/415E-AK
ER 32	20	● 09-ER32-AK
444E / 462E	25	● 09-462E-AK
ER 40 / 450E / 467E	30	● 09-ER40/467E-AK



Für Spannzangen und Futter For collets and collet chucks

- geeignet für Spannzangensatz und Spannzangenfutter SK30 und SK40
- suitable for collet set and collet chucks SK30 and SK40

Passend für / Suitable for	Anzahl der Plätze / Number of seats	Art.-Nr. / Order no.
ER 25	16	● 09-ALK-ER25
ER 32	20	● 09-ALK-ER32
ER 40	24	● 09-ALK-ER40



Für Kantentaster For edge finders

Passend für / Suitable for	Abmessungen / Dimensions mm	Art.-Nr. / Order no.
42-1010-N + 42-10104-N	140 x 56 x 42	● 42-1010-AK

Kantentaster siehe Seite 275
Edge finders see page 275

Schnellwechselstahl- und Schleifbandhalter

Quick-change tool holders and sanding belt holders



ORIGINALMULTISUISSE®



■ Inhalt:

- | Schnellwechselstahlhalter
- | Schleifbandhalter

■ Content:

- | Quick-change tool holders
- | Sanding belt holders



Technische Daten Technical Data

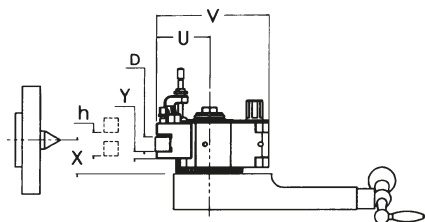

Bei der Wahl der Größe ist zu beachten:

1. Antriebsleistung der Drehbank
2. Spitzhöhe ab Querschlitten „X“
3. Die Länge des Wechselhalters „lg“ soll möglichst der Breite „Z“ des Querschlittens entsprechen
4. Die zu verwendende Stahlhöhe „D“ ergibt zusammen mit der Stahlauflage „Y“ und dem darunter verbleibenden Zwischenraum das erforderliche Maß „X“ (siehe Tabelle)

Pay attention to the following details to find the correct size:

1. Driving motor power
2. Centers height from carriage „X“
3. Length of toolholder „lg“ should possibly correspond to width „Z“ of top slide
4. Height of tool „D“, which together with height „Y“ and the space that remains underneath makes up the necessary size „X“ (see table)

Typ / Type	Aa	A	A	E	E	E	B	B	C	C	C	D1	D1	D1	D2	D2
Stahlhalter D / Toolholder D →	12	16	20	16	20	25	25	32	32	40	45	40	50	63	50	63
Stahlhöhe D / Tool height D ↓	X min.															
6	12															
8	14	17														
10	16	19	19	19	19	22										
12	18	21	21	21	21	24	25	26								
(14)		23	23	23	23	26	27	28	29							
16		25	25	25	25	28	29	30	31	31						
20					29	32	33	34	35	35	38					
25						37	38	39	40	40	43	45				
(30)								44	45	45	48	50	51	52	50	55
32									47	47	50	52	53	54	52	57
40										55	58	60	61	62	60	65
50													71	72	70	75
63														85		88

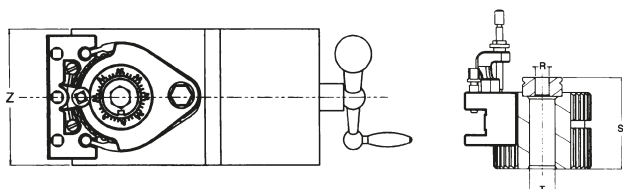

Die Bohrung „R“ in der Zentrierscheibe muss auf das Maß der Spannschraube vergrößert werden.

Hole „R“ in the centring disc must be enlarged up to the size of the clamping screw.

Typ / Type	Aa	A	A	E	E	E	B	B	C	C	C	D1	D1	D1	D2	D2	
Antriebsleistung / Driving power	KW	1	2		4,5		7		13			20			28		
Wechselhalter-Größe / Change toolholder size	D	12	16	20	16	20	25	25	32	32	40	45	40	50	63	50	63
Schlittenbreite max. / Max. carriage width	Z mm	80	100		120		150		180			200			250		
Spitzenhöhe ab Querschlitten min. / Min. centers height from carriage	X min	18	24,5	28,5	24,5	28,5	37	37	45,5	47	55	63	60	70	83	70	88
Spitzenhöhe ab Querschlitten max. / Max. centers height from carriage	X max	26	35,5	39,5	40,5	39,5	43	57	56,5	87	90	93	95	100	103	90	118
Höhenverstellbarkeit / Height adjustability	h mm	8	11		16	11	6	20	11	40	35	30	35	30	20	20	30
Stahlauflage / Tool repose	Y mm	6	8,5	8,5	8,5	8,5	12	12	13,5	15	15	18	20	20	25	20	25
Höhe des Arbeitsstahls max. / Max. tool height	D mm	12	16	20	16	20	25	25	32	32	40	45	40	50	63	50	65
Gesamtbreite max. / Total width	V mm	70	100		125		150		200			230	234	242	275	282	
Gesamthöhe / Total height	S mm	37	56		68		79		110			122			135		
Ausladung max. / Max. distance	U mm	30	48		60		71		90			112	116	124	140	147	
Bohrung Ø max. / Boring Ø max.	T mm	13	20		20		32		40			40			80		



Schnellwechselstahlhalter, ORIGINAL MULTISUISSE® Quick-change tool holders, ORIGINAL MULTISUISSE®

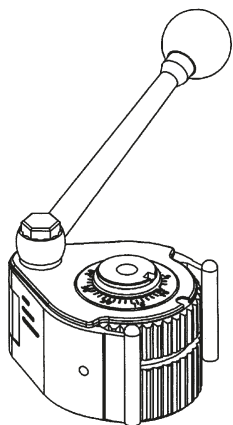

ORIGINAL MULTISUISSE®

Stahlhalterkopf Turret

Größe / Size	Art.-Nr. / Order no.
Aa	● 50-100-100
A	● 50-100-106
E	● 50-100-123
B	● 50-100-141
C	● 50-100-156
D1	● 50-100-177
D2	▶ 50-100-186

ORIGINAL MULTISUISSE®

Drehstahlhalter D Tool holder D

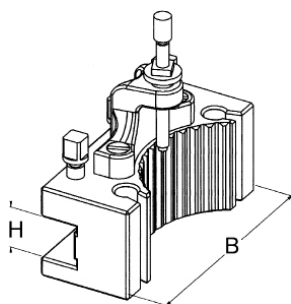

Typ / Type	Für Kopf / For turret	H mm	B mm	Art.-Nr. / Order no.
AaD	Aa	12	50	● 50-100-101
AD	A	16	75	● 50-100-107
AD	A	16	90	● 50-100-108
AD	A	20	75	● 50-100-109
AD	A	20	90	● 50-100-110
ED	E	16	100	● 50-100-124
ED	E	20	100	● 50-100-125
ED	E	25	100	● 50-100-126
BD	B	25	120	● 50-100-142
BD	B	25	140	● 50-100-143
BD	B	32	120	● 50-100-144
BD	B	32	140	● 50-100-145
CD	C	32	150	● 50-100-157
CD	C	32	170	● 50-100-158
CD	C	40	150	● 50-100-159
CD	C	40	170	● 50-100-160
CD	C	45	170	● 50-100-161
D1D	D1	40	180	● 50-100-178
D1D	D1	50	180	● 50-100-179
D1D	D1	63	180	● 50-100-180
D2D	D2	50	220	▶ 50-100-187
D2D	D2	63	220	▶ 50-100-188

ORIGINAL MULTISUISSE®

Bohrstahlhalter H Bar holder H

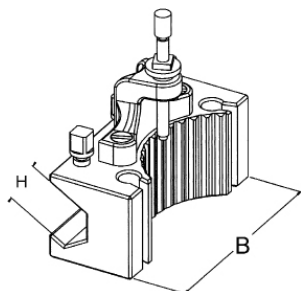

Typ / Type	Für Kopf / For turret	H mm	B mm	Art.-Nr. / Order no.
AaH	Aa	12	50	● 50-100-102
AH	A	20	85	● 50-100-111
EH	E	16	100	● 50-100-127
EH	E	25	100	● 50-100-128
BH	B	32	130	● 50-100-146
CH	C	40	160	● 50-100-162
CH	C	50	160	● 50-100-163
D1H	D1	63	180	● 50-100-181
D2H	D2	70	220	▶ 50-100-189



Schnellwechselstahlhalter, ORIGINAL MULTISUISSE® Quick-change tool holders, ORIGINAL MULTISUISSE®

ORIGINAL MULTISUISSE®

Bohrstangenhalter J Bush holder J

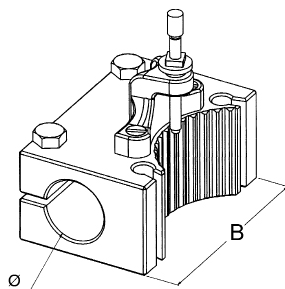

Typ / Type	Für Kopf / For turret	Ø mm	B mm	Art.-Nr. / Order no.
AaJ	Aa	15	50	● 50-100-103
AJ	A	30	80	● 50-100-112
EJ	E	30	100	● 50-100-129
EJ	E	40	100	● 50-100-130
BJ	B	40	120	● 50-100-147
CJ	C	40	160	● 50-100-164
CJ	C	50	160	● 50-100-165
D1J	D1	63	180	● 50-100-182
D2J	D2	63	220	▶ 50-100-190

ORIGINAL MULTISUISSE®

Abstechhalter T Cutting-off holder T

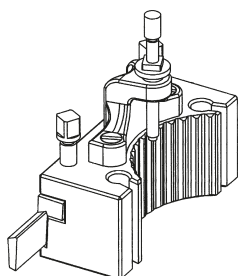

Typ / Type	Für Kopf / For turret	Stahlgröße / Cutting tool size mm	Art.-Nr. / Order no.
AaT	Aa	2,5 x 10	● 50-100-104
AT-K	A	2,7 x 10	● 50-100-113
ET-K	E	4 x 16	● 50-105-131
BT-K	B	4 x 16	● 50-100-148
CT-K	C	5,1 x 18,5	● 50-100-166

ORIGINAL MULTISUISSE®

Rückzugsstahlhalter FE für Außengewinde Thread-cutting device FE for external thread

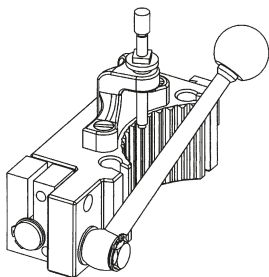

Vorgang: Mit dem Rückzugshebel kann ohne Verstellung des Kreuzsupports aus dem Gewinde ausgefahren werden. Es muß lediglich die neue Spantiefe nachgestellt werden.

Operation: The cutting blade can be retracted from the thread through the handle without moving the cross slide. The next cutting depth can be prepared during the tool's way back.

Typ / Type	Für Kopf / For turret	Hub / Stroke mm	Ø mm	Art.-Nr. / Order no.
AFE	A	11	12	▶ 50-100-115
EFE	E	12	12	▶ 50-100-133
BFE	B	10	20	▶ 50-100-150
CFE	C	14	20	▶ 50-100-168

Schnellwechselstahlhalter, ORIGINAL MULTISUISSE® Quick-change tool holders, ORIGINAL MULTISUISSE®

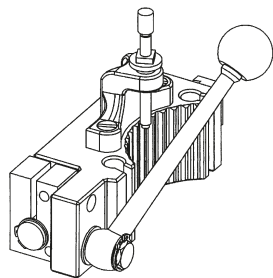

ORIGINAL MULTISUISSE®

Rückzugsstahlhalter FI für Innengewinde Thread-cutting device FI for internal thread

Vorgang: Mit dem Rückzugshebel kann ohne Verstellung des Kreuzsupports aus dem Gewinde ausgefahren werden. Es muß lediglich die neue Spantiefe nachgestellt werden.

Operation: The cutting blade can be retracted from the thread through the handle without moving the cross slide. The next cutting depth can be prepared during the tool's way back.

Typ / Type	Für Kopf / For turret	Hub / Stroke mm	Ø mm	Art.-Nr. / Order no.
AFI	A	11	12	▶ 50-100-116
EFI	E	12	12	▶ 50-100-134
BFI	B	10	20	▶ 50-100-151
CFI	C	14	20	▶ 50-100-169

Hülse mit Morsekegel L für Bohrstangenhalter J Bush with morse taper L for bush holder J

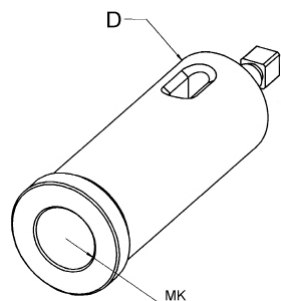

Typ / Type	MK / MT	D mm	Passend für / Matching to	Art.-Nr. / Order no.
AL	1	30	AJ 3080 / EJ 30100	● 50-100-119
AL	2	30	AJ 3080 / EJ 30100	● 50-100-120
BL	2	40	EJ 40100 / BJ 40120 / CJ 40160	● 50-100-135
BL	3	40	EJ 40100 / BJ 40120 / CJ 40160	● 50-100-136
BL	4	40	EJ 40100 / BJ 40120 / CJ 40160	● 50-100-137
CL	3	50	CJ 50160	● 50-100-171
CL	4	50	CJ 50160	● 50-100-172
CL	5	50	CJ 50160	● 50-100-173
DL	5	63	D1J 63180 / D2J 63220	● 50-100-183

ORIGINAL MULTISUISSE®

Einlegeprisma P für Bohrstahlhalter H Prism P for bar holder H

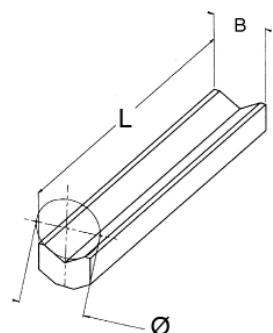

Typ / Type	Ø mm	L mm	B mm	Passend für / Matching to	Art.-Nr. / Order no.
AP	14	85	16	AH 2085	● 50-100-121
EP	16	100	20	EH 16100	● 50-100-138
BP	20	130	22	BH 32130	● 50-100-155
CP	25	160	30	CH 40160	● 50-100-174
CP	32	160	33	CH 50160	● 50-100-175
D1P	40	180	50	D1H 63180	● 50-100-184
D2P	45	220	60	D2H 70220	▶ 50-100-191

ORIGINAL MULTISUISSE®

Bohrstange M passend zu Halter J, ohne Drehling Boring bar M for bush holder J, without tool

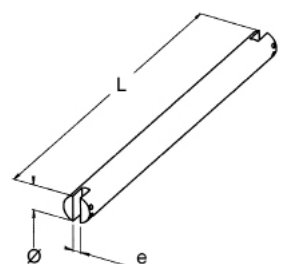







Typ / Type	Ø mm	L mm	e mm	Passend für / Matching to	Art.-Nr. / Order no.
AM	30	250	12	AJ 3080 / EJ 30100	▶ 50-100-122
BM	40	500	12	EJ 40100 / BJ 40120 / CJ 40160	▶ 50-100-140
CM	50	500	12	CJ 50160	▶ 50-100-176
D1M	63	600	12	D1J 63180 / D2J 63220	▶ 50-100-185



Schnellwechselstahlhalter, BASIC Quick-change tool holders, BASIC

















BASIC Kopf Turret



Größe / Size	Art.-Nr. / Order no.
Aa	 BAS-100-100
A	 BAS-100-106
E	 BAS-100-123
B	 BAS-100-141
C	 BAS-100-156
D	 BAS-100-177







BASIC Drehstahlhalter D Tool holder D



Typ / Type	Für Kopf / For turret	H mm	B mm	Art.-Nr. / Order no.
DAa	Aa	12	50	 BAS-100-101
DA	A	20	90	 BAS-100-110
DE	E	20	100	 BAS-100-125
DE	E	25	100	 BAS-100-126
DB	B	25	120	 BAS-100-142
DB	B	25	140	 BAS-100-143
DB	B	32	120	 BAS-100-144
DB	B	32	140	 BAS-100-145
DC	C	32	150	 BAS-100-157
DC	C	32	170	 BAS-100-158
DC	C	40	150	 BAS-100-159
DC	C	40	170	 BAS-100-160
DC	C	45	170	 BAS-100-161
DD	D	40	180	 BAS-100-178
DD	D	50	180	 BAS-100-179
DD	D	63	180	 BAS-100-180

BASIC Bohrstahlhalter H Bar holder H



Typ / Type	Für Kopf / For turret	H mm	B mm	Art.-Nr. / Order no.
HAa	Aa	12	50	 BAS-100-102
HA	A	20	90	 BAS-100-111
HE	E	30	100	 BAS-100-127
HB	B	32	130	 BAS-100-146
HC	C	32	160	 BAS-100-162
HC	C	40	160	 BAS-100-163
HD	D	50	180	 BAS-100-181

M Schnellwechselstahlhalter, BASIC
Quick-change tool holders, BASIC



M BASIC Bohrstangenhalter J
Boring bar holder J

Typ / Type	Für Kopf / For turret	Ø mm	B mm	Art.-Nr. / Order no.
JAa	Aa	15	50	● BAS-100-103
JA	A	30	80	● BAS-100-112
JE	E	30	100	● BAS-100-129
JE	E	40	100	● BAS-100-130
JB	B	40	120	● BAS-100-147
JC	C	40	150	● BAS-100-164
JC	C	50	150	● BAS-100-165
JD	D	63	180	● BAS-100-182



M BASIC Abstechhalter T
Cutting-off holder T

Typ / Type	Für Kopf / For turret	Stahlgröße / Cutting tool size mm	Art.-Nr. / Order no.
TAa	Aa	2,7 x 10	● BAS-100-104
TA	A	2,7 x 10	● BAS-100-113
TE	E	2,7 x 10	● BAS-100-131
TB	B	4 x 16	● BAS-100-148
TC	C	5 x 18,5	● BAS-100-166

MK-Hülsen, Einlegeprismen und Bohrstangen siehe Seite 209. Ersatzteile auf Anfrage
For MT-sleeves, prism inserts and boring bars refer to page 209. Spare parts upon request

M BASIC Schnellwechselstahlhalter-Sätze
Quick-change tool holder sets

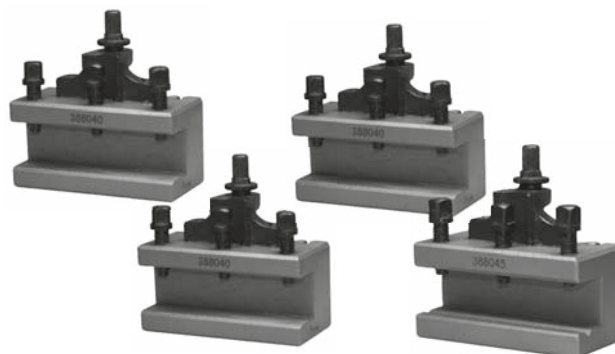

Satz bestehend aus / Set consisting of

Größe / Size	Kopf / Turret	Drehstahlhalter / Tool holder	Bohrstahlhalter / Bar holder	Art.-Nr. / Order no.
Aa	1 x BAS-100-100	3 x BAS-100-101	1 x BAS-100-102	● BAS-SATZ-AA
A	1 x BAS-100-106	3 x BAS-100-110	1 x BAS-100-111	● BAS-SATZ-A
E	1 x BAS-100-123	3 x BAS-100-125	1 x BAS-100-127	● BAS-SATZ-E
B	1 x BAS-100-141	3 x BAS-100-142	1 x BAS-100-146	● BAS-SATZ-B
C	1 x BAS-100-156	3 x BAS-100-157	1 x BAS-100-163	● BAS-SATZ-C



Ersatzteile für Schnellwechselstahlhalter

Spare parts for quick-change tool holders

Exzentrerschlüssel

Lever



Für Kopf / For turret	Art.-Nr. / Order no.
Aa	▶ 50-100-221
A	▶ 50-100-222
E	● 50-100-223
B	● 50-100-223
C	▶ 50-100-225
D1	▶ 50-100-226
D2	▶ 50-100-227

Vierkantschraube

Square head screw



Für Kopf / For turret	Art.-Nr. / Order no.
Aa	▶ 50-100-249
A	● 50-100-250
E	● 50-100-250
B	● 50-100-251
C	● 50-100-252
D1	● 50-100-252
D2	▶ 50-100-253

Ringfeder

Spring



Für Kopf / For turret	Art.-Nr. / Order no.
A	▶ 50-100-301
E	▶ 50-100-301
B	● 50-100-303
C	● 50-100-304
D1	▶ 50-100-305
D2	▶ 50-100-306

Höhenverstellerschraube

Height adjusting screw



Für Kopf / For turret	Art.-Nr. / Order no.
Aa	▶ 50-100-254
A	● 50-100-255
E	● 50-100-370
B	● 50-100-256
C	● 50-100-257
D1	▶ 50-100-258
D2	▶ 50-100-258

Höhenverstellmutter

Stop nut



Für Kopf / For turret	Art.-Nr. / Order no.
Aa	▶ 50-100-259
A	● 50-100-260
E	● 50-100-260
B	● 50-100-261
C	● 50-100-262
D1	▶ 50-100-263
D2	▶ 50-100-263

Zeiger

Guard ring



Für Kopf / For turret	Art.-Nr. / Order no.
A	▶ 50-100-294
E	▶ 50-100-294
B	▶ 50-100-296
C	▶ 50-100-297
D1	▶ 50-100-298
D2	▶ 50-100-299

Konsole mit Schrauben und Mutter

Bracket with screws



Für Kopf / For turret	Art.-Nr. / Order no.
Aa	▶ 50-100-242
A	▶ 50-100-243
E	▶ 50-100-244
B	● 50-100-245
C	▶ 50-100-246
D1	▶ 50-100-247
D2	▶ 50-100-248

Vierkantsteckschlüssel

Socket wrench



Für Kopf / For turret	Art.-Nr. / Order no.
Aa	▶ 50-100-228
A	● 50-100-229
E	● 50-100-229
B	● 50-100-231
C	▶ 50-100-232
D1	▶ 50-100-232
D2	▶ 50-100-234

Spannband mit Exzenterbolzen

Clamping strap with eccentric bolt



Für Kopf / For turret	Art.-Nr. / Order no.
Aa	▶ 50-100-264
A	▶ 50-100-265
E	▶ 50-100-266
B	▶ 50-100-267
C	▶ 50-100-268
D1	▶ 50-100-269
D2	▶ 50-100-270

Schleifbandhalter Sanding belt holders

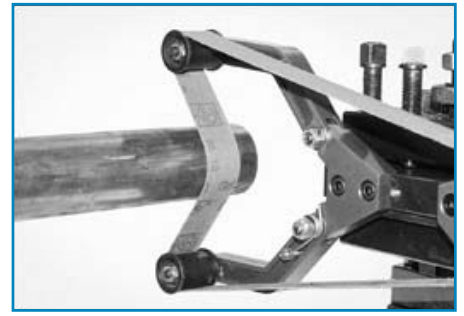

Schleifbandhalter, manuell Sanding belt holders, manually

- zum Einspannen in Drehstahlhalter
- Betätigung mittels Handkurbel
- zum Schleifen und Entgraten von Werkstücken
- for use in quick-change tool holders
- operated by hand crank
- used for the sanding and deburring of workpieces

Größe / Size	Ø Max. mm	Art.-Nr. / Order no.
1	155	ZE-SBH-100
2	210	ZE-SBH-200
4	423	ZE-SBH-400



Schleifbandhalter, automatisch Sanding belt holders, automatically

- zum Einspannen in Drehstahlhaltern
- mit automatischem Schiebesystem
- zum Schleifen und Entgraten von Werkstücken
- for use in quick-change tool holders
- with automatic sliding system
- used for the sanding and deburring of workpieces

Größe / Size	Ø Max. mm	Art.-Nr. / Order no.
1	155	ZE-ABH-100
2	210	ZE-ABH-200

Schleifbänder Sanding belts



Passend zu Größe / Fitting to size	Breite / Width mm	Länge / Length mm	Körnung / Grain	Art.-Nr. / Order no.
1	25	762	80	ZE-SBH-100/S80
1	25	762	100	ZE-SBH-100/S100
1	25	762	120	ZE-SBH-100/S120
1	25	762	180	ZE-SBH-100/S180
1	25	762	240	ZE-SBH-100/S240
1	25	762	320	ZE-SBH-100/S320
2	50	915	80	ZE-SBH-200/S80
2	50	915	100	ZE-SBH-200/S100
2	50	915	150	ZE-SBH-200/S150
2	50	915	180	ZE-SBH-200/S180
2	50	915	220	ZE-SBH-200/S220
2	50	915	320	ZE-SBH-200/S320
4	100	1372	80	ZE-SBH-400/S80
4	100	1372	120	ZE-SBH-400/S120
4	100	1372	150	ZE-SBH-400/S150
4	100	1372	220	ZE-SBH-400/S220
4	100	1372	320	ZE-SBH-400/S320



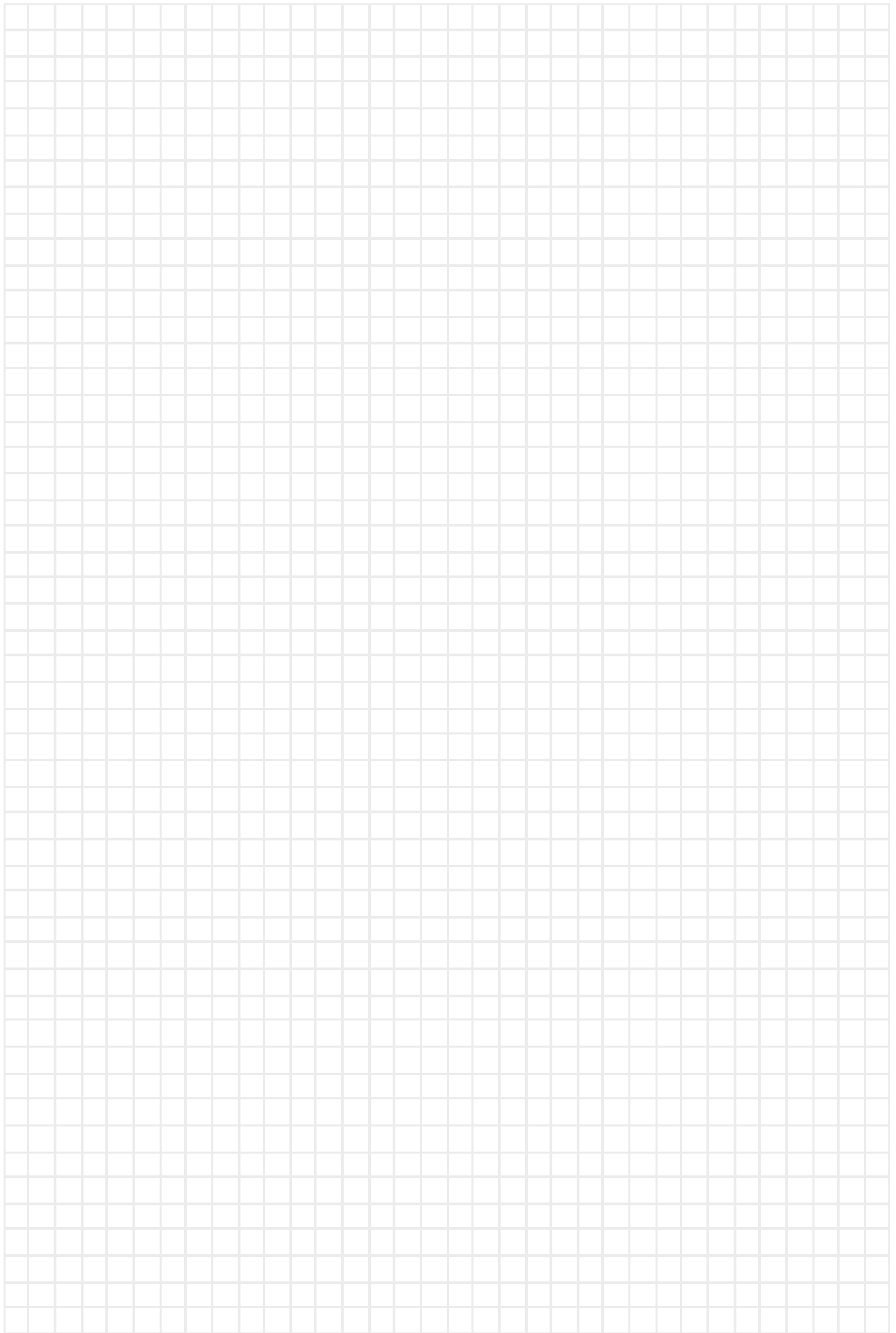

Werkzeugaufnahmen für Fräsmaschinen

MK-SK-Zylinderschaft-HSK

Tool holders for milling machines

MT-SK-Straight shank-HSK



■ Inhalt:

- 11.1 | Werkzeugaufnahmen-Sätze
- 11.2 | Morsekegelaufnahmen
- 11.3 | DIN 2080
- 11.4 | DIN 69871
- 11.5 | MAS BT
- 11.6 | Aufnahmen mit Zylinderschaft
- 11.7 | DIN 69893 HSK - A
- 11.8 | Anzugsbolzen

■ Content:

- 11.1 | *Tool holder sets*
- 11.2 | *Morse taper tooling*
- 11.3 | *DIN 2080*
- 11.4 | *DIN 69871*
- 11.5 | *MAS BT*
- 11.6 | *Straight shank tooling*
- 11.7 | *DIN 69893 HSK - A*
- 11.8 | *Pull studs*





Spannzangen-Sätze ER mit Futter im Aluminium-Koffer Collet sets ER with chucks in aluminium case

- Lieferumfang: Spannzangenfutter, Spannzangensatz, Aluminiumkoffer und Schlüssel
- scope of delivery: collet chuck, collet set, aluminium case and spanner
- 1 mm steigend
- 1 mm stepped

DIN	Schaft / Shank	SZ-Satz / Collet set	Art.-Nr. / Order no.
DIN 228	MK / MT 2	ER 25 (Ø 2-16)	● SZ-MK2-ER25
DIN 228	MK / MT 2	ER 32 (Ø 3-20)	● SZ-MK2-ER32
DIN 228	MK / MT 3	ER 32 (Ø 3-20)	● SZ-MK3-ER32
DIN 228	MK / MT 4	ER 32 (Ø 3-20)	● SZ-MK4-ER32
DIN 228	MK / MT 4	ER 40 (Ø 4-26)	● SZ-MK4-ER40
DIN 69871	SK 40	ER 25 (Ø 2-16)	● SZ-SK40-ER25
DIN 69871	SK 40	ER 32 (Ø 3-20)	● SZ-SK40-ER32
DIN 69871	SK 40	ER 40 (Ø 4-26)	● SZ-SK40-ER40
DIN 2080	SK 40	ER 25 (Ø 2-16)	● SZ-ISO40-ER25
DIN 2080	SK 40	ER 32 (Ø 3-20)	● SZ-ISO40-ER32
DIN 2080	SK 40	ER 40 (Ø 4-26)	● SZ-ISO40-ER40
MAS BT	SK 40	ER 25 (Ø 2-16)	● SZ-BT40-ER25
MAS BT	SK 40	ER 32 (Ø 3-20)	● SZ-BT40-ER32
MAS BT	SK 40	ER 40 (Ø 4-26)	● SZ-BT40-ER40
DIN 69893-A	HSK 63	ER 25 (Ø 2-16)	● SZ-HSK63A-ER25
DIN 69893-A	HSK 63	ER 32 (Ø 3-20)	● SZ-HSK63A-ER32
DIN 69893-A	HSK 63	ER 40 (Ø 4-26)	● SZ-HSK63A-ER40
Zyl. / Cyl.	Ø 16 x 130	ER 11 (Ø 1-7) *	● 13-7600-16-ER11M-130
Zyl. / Cyl.	Ø 20 x 130	ER 16 (Ø 1-10)	● 13-7600-20-ER16M-130
Zyl. / Cyl.	Ø 20 x 160	ER 16 (Ø 1-10)	● 13-7600-20-ER16M-160
Zyl. / Cyl.	Ø 20 x 130	ER 20 (Ø 2 - 13)	● 13-7600-20-ER20M-130
Zyl. / Cyl.	Ø 20 x 200	ER 20 (Ø 2 - 13)	● 13-7600-20-ER20M-200

* 0,5mm steigend / 0,5mm stepped

Spannzangen-Sätze OZ mit Futter im Aluminium-Koffer Collet sets OZ with chucks in aluminium case

DIN	Schaft / Shank	SZ-Satz / Collet set	Art.-Nr. / Order no.
DIN 228	MK / MT 3	462E (Ø 3-13,16,18,20,25)	● SZ-SATZ-462E-MK3
DIN 2080	SK 40	462E (Ø 3-13,16,18,20,25)	● SZ-SATZ-462E-SK40

Weitere Spannzangen-Sätze mit Futter bis Größe SK 45 auf Anfrage
Further collet sets with collet chuck up to size SK 45 upon request



Aluminiumkoffer Aluminium case

- für Spannzangen-Sätze und Spannzangenfutter SK 30 und SK 40
- for collet sets and collet chucks SK 30 and SK 40

Passend für / Suitable for	Anzahl d. Bohrungen / Number of seats	Art.-Nr. / Order no.
ER 25	16	● 09-ALK-ER25
ER 32	20	● 09-ALK-ER32
ER 40	24	● 09-ALK-ER40

Aufsteckhalter mit Morsekegel für Reibahlen DIN 219
Arbors with morse taper for reamers DIN 219

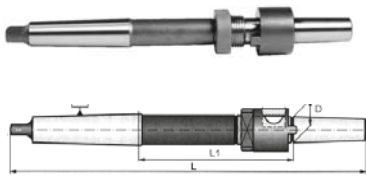

MK / MT	D mm	L mm	L1 mm	Art.-Nr. / Order no.
2	10	220	105,8	● 13-5310-2-10
3	13	250	111,9	● 13-5310-3-13
3	16	261	117,9	● 13-5310-3-16
3	19	270	121,1	● 13-5310-3-19
3	22	278	122,1	● 13-5310-3-22
4	19	298	125,6	● 13-5310-4-19
4	22	312	132,6	● 13-5310-4-22
4	27	325	137,6	● 13-5310-4-27
4	32	345	148,9	● 13-5310-4-32
5	27	359	139,6	● 13-5310-5-27
5	32	376	147,9	● 13-5310-5-32
5	40	396	157,9	● 13-5310-5-40
5	50	416	167,9	✱ 13-5310-5-50

Flächenspannfutter WELDON mit Morsekegel
End mill adaptors WELDON with morse taper

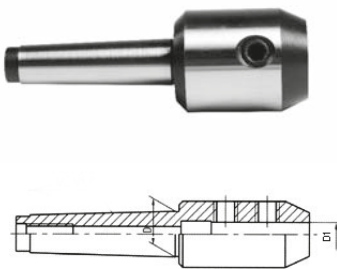

MK / MT	D1 mm	Art.-Nr. / Order no.
2	4	● 13-7721-2-4
2	6	● 13-7721-2-6
2	8	● 13-7721-2-8
2	10	● 13-7721-2-10
2	12	● 13-7721-2-12
2	14	● 13-7721-2-14
2	16	● 13-7721-2-16
2	18	● 13-7721-2-18
2	20	● 13-7721-2-20
3	4	● 13-7721-3-4
3	6	● 13-7721-3-6
3	8	● 13-7721-3-8
3	10	● 13-7721-3-10
3	12	● 13-7721-3-12
3	14	● 13-7721-3-14
3	16	● 13-7721-3-16
3	18	● 13-7721-3-18
3	20	● 13-7721-3-20
3	25	● 13-7721-3-25
4	6	● 13-7721-4-6
4	8	● 13-7721-4-8
4	10	● 13-7721-4-10
4	12	● 13-7721-4-12
4	14	● 13-7721-4-14
4	16	● 13-7721-4-16
4	18	● 13-7721-4-18
4	20	● 13-7721-4-20
4	25	● 13-7721-4-25
4	32	● 13-7721-4-32
4	40	● 13-7721-4-40

Einschraubbare Austreiblappen siehe Seite 264
Removable tangs see page 264



Morsekegelaufnahmen Morse taper tooling

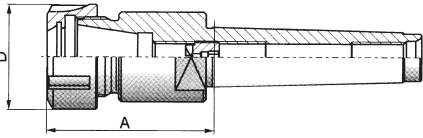

Spannzangenfutter ER mit Morsekegel Collet chucks ER with morse taper

Größe / Size	Spannzange / Collet	A mm	D mm	Spannbe- reich / Clamping range	Art.-Nr. / Order no.
MK 2	ER 16	50	32	2-10	13-7711-2-16
MK 2	ER 20	50	35	2-13	13-7711-2-20
MK 2	ER 25	60	42	2-16	13-7711-2-25
MK 2	ER 32	60	50	2-20	13-7711-2-32
MK 2	ER 40	80	63	2-26	13-7711-2-40
MK 3	ER 16	50	32	2-10	13-7711-3-16
MK 3	ER 20	50	35	2-13	13-7711-3-20
MK 3	ER 25	56	42	2-16	13-7711-3-25
MK 3	ER 32	60	50	2-20	13-7711-3-32
MK 3	ER 40	80	63	2-26	13-7711-3-40
MK 4	ER 25	60	42	2-16	13-7711-4-25
MK 4	ER 32	60	50	2-20	13-7711-4-32
MK 4	ER 40	80	63	2-26	13-7711-4-40
MK 5	ER 32	80	50	2-20	13-7711-5-32
MK 5	ER 40	80	63	2-26	13-7711-5-40

Spannzangenfutter OZ mit Morsekegel Collet chucks OZ with morse taper



Größe / Size	Spannzange / Collet	A mm	Spannbereich / Clamping range	Art.-Nr. / Order no.
MK 2	OZ16 (415E)	62	2-16	09-6310216057
MK 2	OZ25 (462E)	85	2-25	09-6310225076
MK 3	OZ25 (462E)	70	2-25	09-6310325090
MK 4	OZ25 (462E)	70	2-25	09-6310425090
MK 5	OZ25 (462E)	75	2-25	09-6310525090

Kombi-Fräseraufsteckdorne mit Morsekegel Combination shell mill adaptors with morse taper

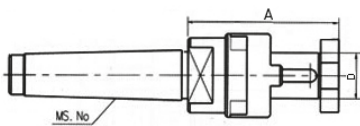

Größe / Size	D mm	A mm	Art.-Nr. / Order no.
MK 2	13	58	13-7430-2-13
MK 2	16	48	13-7430-2-16
MK 2	22	48	13-7430-2-22
MK 2	27	55	13-7430-2-27
MK 3	16	48	13-7430-3-16
MK 3	22	48	13-7430-3-22
MK 3	27	55	13-7430-3-27
MK 3	32	55	13-7430-3-32
MK 4	16	55	13-7430-4-16
MK 4	22	55	13-7430-4-22
MK 4	27	55	13-7430-4-27
MK 4	32	55	13-7430-4-32
MK 4	40	55	13-7430-4-40

Einschraubbare Austreiblappen siehe Seite 264
Removable tangs see page 264



Morsekegelaufnahmen Morse taper tooling

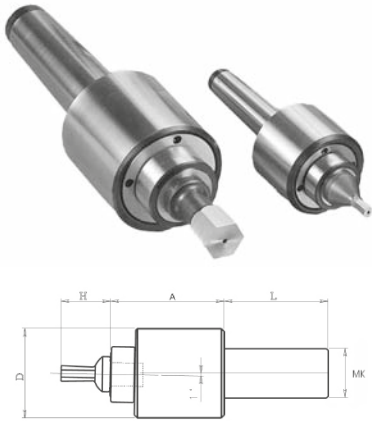

Räumwerkzeughalter mit Morsekegel Broach tool holders with morse taper

Größe / Size	D mm	L mm	A mm	H mm	Aufnahme / Mounting	Art.-Nr. / Order no.
MK 2	44	69	46	25	Ø 12	47-RHV-MK2-12
MK 3	58	85	76	40	Ø 16	47-RHV-MK3-16

Passende Räumstempel siehe Seiten 175 - 177
Suitable cutters see pages 175 - 177

DIN 2080

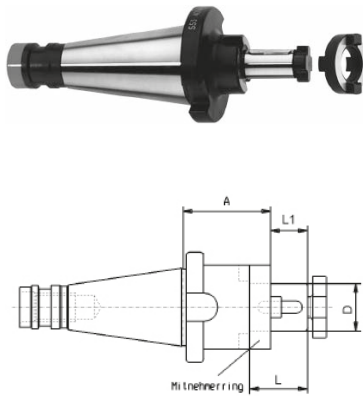

Kombi-Fräseraufsteckdorne DIN 2080 Combination shell mill adaptors DIN 2080

Größe / Size	D mm	A mm	L mm	L1 mm	Art.-Nr. / Order no.
SK 30	13	35	22	12	* 13-7332-30-13
SK 30	16	35	27	17	● 13-7332-30-16
SK 30	22	35	31	19	● 13-7332-30-22
SK 30	27	35	33	21	● 13-7332-30-27
SK 40	13	52	22	12	● 13-7332-40-13
SK 40	16	52	27	17	● 13-7332-40-16
SK 40	22	52	32	19	● 13-7332-40-22
SK 40	27	52	33	21	● 13-7332-40-27
SK 40	32	52	38	24	● 13-7332-40-32
SK 40	40	52	41	27	● 13-7332-40-40
SK 50	16	55	27	17	● 13-7332-50-16
SK 50	22	55	31	19	● 13-7332-50-22
SK 50	27	55	33	21	● 13-7332-50-27
SK 50	32	55	38	24	● 13-7332-50-32
SK 50	40	55	41	27	● 13-7332-50-40
SK 50	50	55	46	30	* 13-7332-50-50

Messerkopf-Aufnahmen DIN 2080 Face mill holders DIN 2080

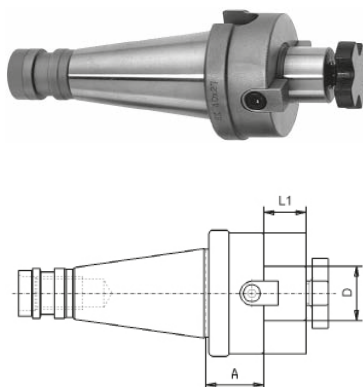

Größe / Size	D mm	A mm	L1 mm	Art.-Nr. / Order no.
SK 40	16	30	17	● 13-7311-40-16
SK 40	22	30	19	● 13-7311-40-22
SK 40	27	30	21	● 13-7311-40-27
SK 40	32	30	24	● 13-7311-40-32
SK 40	40	30	27	● 13-7311-40-40
SK 50	22	35	19	● 13-7311-50-22
SK 50	27	35	21	● 13-7311-50-27
SK 50	32	40	24	● 13-7311-50-32
SK 50	40	40	27	● 13-7311-50-40



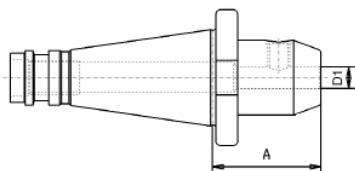

Flächenspannfutter WELDON DIN 2080
End mill adaptors WELDON DIN 2080

Größe / Size	D1 mm	A mm	Art.-Nr. / Order no.
SK 40	6	50	● 13-7620-40-6-50
SK 40	8	50	● 13-7620-40-8-50
SK 40	10	50	● 13-7620-40-10-50
SK 40	12	50	● 13-7620-40-12-50
SK 40	14	50	● 13-7620-40-14-50
SK 40	16	63	● 13-7620-40-16-63
SK 40	20	63	● 13-7620-40-20-63
SK 40	25	80	● 13-7620-40-25-80
SK 40	32	80	● 13-7620-40-32-80
SK 50	6	63	● 13-7620-50-6-63
SK 50	8	63	● 13-7620-50-8-63
SK 50	10	63	● 13-7620-50-10-63
SK 50	12	63	● 13-7620-50-12-63
SK 50	14	63	● 13-7620-50-14-63
SK 50	16	63	● 13-7620-50-16-63
SK 50	18	63	● 13-7620-50-18-63
SK 50	20	63	● 13-7620-50-20-63
SK 50	25	80	● 13-7620-50-25-80
SK 50	32	80	● 13-7620-50-32-80
SK 50	40	90	● 13-7620-50-40-90

Bohrfutteraufnahmen DIN 2080
Drill chuck adaptors DIN 2080

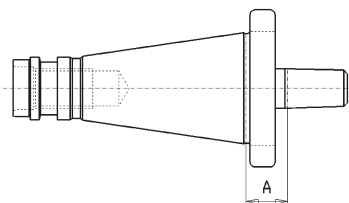

Größe / Size	Kegel / Taper	A mm	Art.-Nr. / Order no.
SK 30	B16	17	● 13-5370-30-B16
SK 40	B12	18	● 13-5370-40-B12
SK 40	B16	18	● 13-5370-40-B16
SK 40	B18	18	● 13-5370-40-B18
SK 50	B16	20	● 13-5370-50-B16
SK 50	B18	20	● 13-5370-50-B18

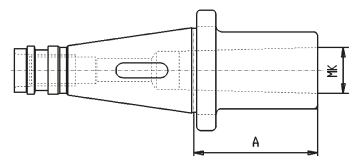

**Zwischenhülsen DIN 2080 für MK-Werkzeuge
mit Austreiblappen**
Reducing adaptors DIN 2080 for MT tools with tang

Größe / Size	MK / MT	A mm	Art.-Nr. / Order no.
SK 40	1	50	● 13-1679-40/1
SK 40	2	50	● 13-1679-40/2
SK 40	3	65	● 13-1679-40/3
SK 40	4	95	● 13-1679-40/4
SK 50	1	45	● 13-1679-50/1
SK 50	2	50	● 13-1679-50/2
SK 50	3	65	● 13-1679-50/3
SK 50	4	70	● 13-1679-50/4
SK 50	5	105	● 13-1679-50/5



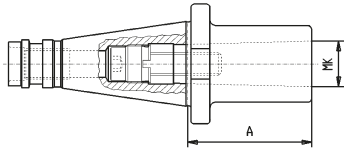

Zwischenhülsen DIN 2080 für MK-Werkzeuge mit Anzugsgewinde
Reducing adaptors DIN 2080 for MT tools with thread

- mit Anzugsgewinde DIN 6364

- with thread DIN 6364

Größe / Size	MK / MT	A mm	Art.-Nr. / Order no.
SK 40	1	50	● 13-1676-40/1
SK 40	2	50	● 13-1676-40/2
SK 40	3	65	● 13-1676-40/3
SK 40	4	95	● 13-1676-40/4
SK 50	1	60	● 13-1676-50/1
SK 50	2	60	● 13-1676-50/2
SK 50	3	65	● 13-1676-50/3
SK 50	4	65	● 13-1676-50/4
SK 50	5	120	● 13-1676-50/5

Spannzangenfutter ER DIN 2080
Collet chucks ER DIN 2080

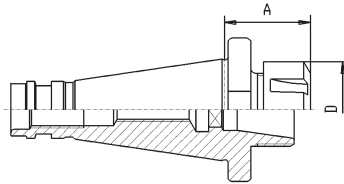

Größe / Size	Spannzange / Collet	A mm	D mm	Art.-Nr. / Order no.
SK 30	ER 16	50	28	● 13-7616-30-16
SK 30	ER 32	50	42	● 13-7616-30-32
SK 40	ER 16	50	28	● 13-7616-40-16
SK 40	ER 25	50	42	● 13-7616-40-25
SK 40	ER 32	60	50	● 13-7616-40-32
SK 40	ER 40	60	63	● 13-7616-40-40
SK 50	ER 32	70	50	● 13-7616-50-32
SK 50	ER 40	70	63	● 13-7616-50-40

Spannzangenfutter OZ DIN 2080
Collet chucks OZ DIN 2080

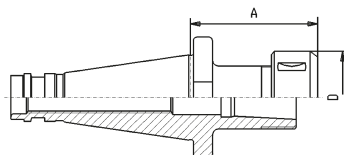

Größe / Size	Spannzange / Collet	A mm	D mm	Art.-Nr. / Order no.
SK 40	OZ16 (415E)	70	43	● 13-7605-40-16
SK 40	OZ25 (462E)	70	60	● 13-7605-40-25
SK 40	OZ32 (467E)	80	72	● 13-7605-40-32
SK 50	OZ32 (467E)	80	72	● 13-7605-50-32

Fräseraufnahme DIN 2080 mit Kühlmittelring für IKZ
Weldon chuck DIN 2080 with cooling agent ring

- mit Kühlmittelring für innere Kühlmittelzufuhr
- Aufnahmebohrung nach DIN 1835B (Weldon)
- with cooling agent ring for internal-coolant supply
- according to DIN 1835B (Weldon)

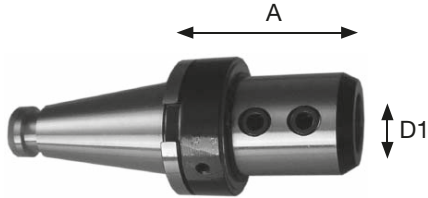

Größe / Size	D1 mm	A mm	Art.-Nr. / Order no.
SK 40	20	70	09-FSKR-ISO-40-20
SK 40	25	100	09-FSKR-ISO-40-25
SK 40	32	110	09-FSKR-ISO-40-32
SK 40	40	120	09-FSKR-ISO-40-40
SK 50	20	70	09-FSKR-ISO-50-20
SK 50	25	100	09-FSKR-ISO-50-25
SK 50	32	110	09-FSKR-ISO-50-32
SK 50	40	120	09-FSKR-ISO-50-40

Passende Reduzierhülsen siehe Seite 238
Suitable reduction sleeves see page 238

Bohrfutter DIN 2080
Drill chucks DIN 2080

- inkl. Hakenschlüssel
- incl. hook wrench

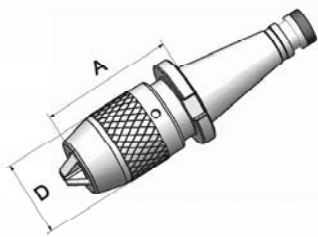

Größe / Size	Spannweite / Capacity mm	D mm	A mm	Rundlaufgenauigkeit / Runout mm	Art.-Nr. / Order no.
SK 40	1-13	50	95	0,05	13-7657-40-13
SK 40	3-16	57	100	0,05	13-7657-40-16
SK 50	3-16	55	115	0,05	13-7657-50-16

Rohlinge DIN 2080
Blanks DIN 2080

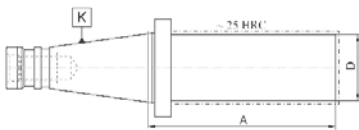

Größe / Size	D mm	A mm	Art.-Nr. / Order no.
SK 40	40	280	13-2190-40-40-280
SK 40	63	280	13-2190-40-63-280
SK 50	50	330	13-2190-50-50-330
SK 50	80	330	13-2190-50-80-330

Lange Fräserdorne nach DIN 6355
Long milling arbors DIN 6355

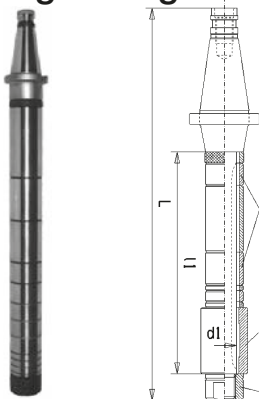

	Art.-Nr. / Order no.
Fräserdorn mit Mutter, Endring und Passfeder / Arbor with nut, end ring and fitted key Form A: 40x13x315 - 50x60x800	13-7175-?
Fräserdorn mit Mutter, Ringsatz und Passfeder / Arbor with nut, spacing collars, end ring and fitted key Form B: 40x13x315 - 50x60x800	13-7178-?
Fräserdorn mit Mutter, 1 Laufbuchse, Ringsatz und Passfeder / Arbor with nut, spacing collars, 1 sleeve, end ring and fitted key Form C: 40x13x315 - 50x60x800	13-7181-?
Fräserdorn mit Mutter, 2 Laufbuchsen, Ringsatz und Passfeder / Arbor with nut, spacing collars, 2 sleeves, end ring and fitted key Form D: 40x13x315 - 50x60x800	13-7184-?



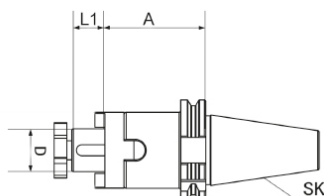

Gewuchtet G = 6,3 15.000 U/min.
Balanced G = 6,3 15.000 U/min.

Kombi-Fräseraufsteckdorne DIN 69871 Combination shell mill adaptors DIN 69871

Größe / Size	D mm	A mm	L mm	L1 mm	Art.-Nr. / Order no.
SK 40	13	55	22	12	● 13-7301-40-13
SK 40	16	55	27	17	● 13-7301-40-16
SK 40	22	55	32	19	● 13-7301-40-22
SK 40	27	55	33	21	● 13-7301-40-27
SK 40	32	60	38	24	● 13-7301-40-32
SK 40	40	60	41	27	● 13-7301-40-40
SK 50	16	55	27	17	● 13-7301-50-16
SK 50	22	55	31	19	● 13-7301-50-22
SK 50	27	55	33	21	● 13-7301-50-27
SK 50	32	55	38	24	● 13-7301-50-32
SK 50	40	55	41	27	● 13-7301-50-40

Messerkopf-Aufnahmen DIN 69871 Face mill holders DIN 69871

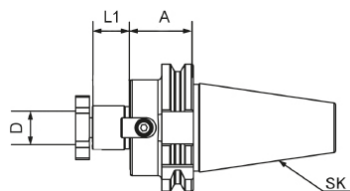

Gewuchtet G = 6,3 15.000 U/min.
Balanced G = 6,3 15.000 U/min.

Größe / Size	D mm	A mm	L1 mm	Art.-Nr. / Order no.
SK 40	16	35	17	● 13-7369-40-16
SK 40	16	100	17	● 13-7369-40-16-100
SK 40	22	35	19	● 13-7369-40-22
SK 40	22	100	19	● 13-7369-40-22-100
SK 40	22	160	19	▶ 13-7369-40-22-160
SK 40	27	40	21	● 13-7369-40-27
SK 40	27	100	21	● 13-7369-40-27-100
SK 40	27	160	21	▶ 13-7369-40-27-160
SK 40	32	50	24	● 13-7369-40-32
SK 40	32	100	24	● 13-7369-40-32-100
SK 40	32	160	24	▶ 13-7369-40-32-160
SK 40	40	50	27	● 13-7369-40-40
SK 40	40	100	27	▶ 13-7369-40-40-100
SK 40	40	160	27	▶ 13-7369-40-40-160
SK 50	22	35	19	● 13-7369-50-22
SK 50	22	100	19	● 13-7369-50-22-100
SK 50	22	160	19	▶ 13-7369-50-22-160
SK 50	27	40	21	● 13-7369-50-27
SK 50	27	100	21	● 13-7369-50-27-100
SK 50	27	160	21	▶ 13-7369-50-27-160
SK 50	32	50	24	● 13-7369-50-32
SK 50	32	100	24	● 13-7369-50-32-100
SK 50	32	160	24	▶ 13-7369-50-32-160
SK 50	40	50	27	● 13-7369-50-40
SK 50	40	100	27	● 13-7369-50-40-100
SK 50	40	160	27	✱ 13-7369-50-40-160
SK 50	50	60	30	✱ 13-7369-50-50*

* Gewuchtet G = 6,3 12.000 U/min.
* Balanced G = 6,3 12.000 U/min.

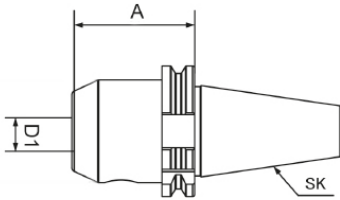

Gewuchtet G = 6,3 15.000 U/min.
Balanced G = 6,3 15.000 U/min.

Flächenspannfutter WELDON DIN 69871
End mill adaptors WELDON DIN 69871

Größe / Size	D1 mm	A mm	Art.-Nr. / Order no.
SK 40	6	50	● 13-7625-40-6-50
SK 40	6	100	● 13-7625-40-6-100
SK 40	6	160	● 13-7625-40-6-160
SK 40	8	50	● 13-7625-40-8-50
SK 40	8	100	● 13-7625-40-8-100
SK 40	8	160	● 13-7625-40-8-160
SK 40	10	50	● 13-7625-40-10-50
SK 40	10	100	● 13-7625-40-10-100
SK 40	10	160	● 13-7625-40-10-160
SK 40	12	50	● 13-7625-40-12-50
SK 40	12	100	● 13-7625-40-12-100
SK 40	12	160	● 13-7625-40-12-160
SK 40	14	50	● 13-7625-40-14-50
SK 40	14	100	● 13-7625-40-14-100
SK 40	14	160	● 13-7625-40-14-160
SK 40	16	63	● 13-7625-40-16-63
SK 40	16	100	● 13-7625-40-16-100
SK 40	16	160	● 13-7625-40-16-160
SK 40	18	63	● 13-7625-40-18-63
SK 40	18	100	● 13-7625-40-18-100
SK 40	18	160	▶ 13-7625-40-18-160
SK 40	20	63	● 13-7625-40-20-63
SK 40	20	100	● 13-7625-40-20-100
SK 40	20	160	● 13-7625-40-20-160
SK 40	22	63	● 13-7625-40-22-63
SK 40	25	100	● 13-7625-40-25-100
SK 40	25	160	● 13-7625-40-25-160
SK 40	32	100	● 13-7625-40-32-100
SK 40	32	160	● 13-7625-40-32-160
SK 40	40	120	● 13-7625-40-40-115
SK 50	6	63	● 13-7625-50-6-63
SK 50	6	100	● 13-7625-50-6-100
SK 50	6	160	● 13-7625-50-6-160
SK 50	8	63	● 13-7625-50-8-63
SK 50	8	100	● 13-7625-50-8-100
SK 50	8	160	● 13-7625-50-8-160
SK 50	10	63	● 13-7625-50-10-63
SK 50	10	100	● 13-7625-50-10-100
SK 50	10	160	● 13-7625-50-10-160
SK 50	12	63	● 13-7625-50-12-63
SK 50	12	100	● 13-7625-50-12-100
SK 50	12	160	● 13-7625-50-12-160
SK 50	14	63	● 13-7625-50-14-63
SK 50	14	100	● 13-7625-50-14-100
SK 50	16	63	● 13-7625-50-16-63
SK 50	16	100	● 13-7625-50-16-100
SK 50	16	160	● 13-7625-50-16-160
SK 50	18	63	● 13-7625-50-18-63
SK 50	18	100	● 13-7625-50-18-100
SK 50	20	63	● 13-7625-50-20-63
SK 50	20	100	● 13-7625-50-20-100
SK 50	20	160	● 13-7625-50-20-160
SK 50	25	80	● 13-7625-50-25-80
SK 50	25	100	● 13-7625-50-25-100
SK 50	32	100	● 13-7625-50-32-100
SK 50	32	160	● 13-7625-50-32-160
SK 50	40	120	● 13-7625-50-40-120

Weitere Größen siehe nächste Seite
Further sizes see next page



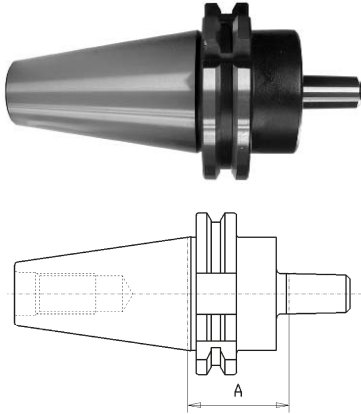

Gewuchtet G = 6,3 15.000 U/min.
Balanced G = 6,3 15.000 U/min.

Bohrfutteraufnahmen DIN 69871
Drill chuck adaptors DIN 69871

Größe / Size	Kegel / Taper	A mm	Art.-Nr. / Order no.
SK 40	B12	25	13-5374-40-B12
SK 40	B16	25	13-5374-40-B16
SK 40	B18	35	13-5374-40-B18
SK 50	B16	25	13-5374-50-B16
SK 50	B18	25	13-5374-50-B18

**Zwischenhülsen DIN 69871 für MK-Werkzeuge
mit Austreibblappen**
Reducing adaptors DIN 69871 for MT tools with tang

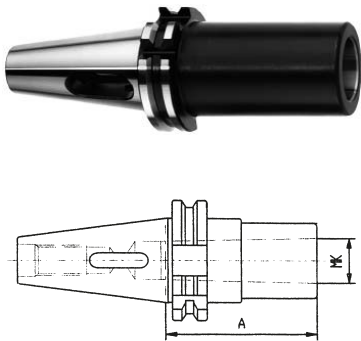

Gewuchtet G = 6,3 15.000 U/min.
Balanced G = 6,3 15.000 U/min.

Größe / Size	MK / MT	A mm	Art.-Nr. / Order no.
SK 40	1	50	13-1681-40/1
SK 40	2	50	13-1681-40/2
SK 40	3	70	13-1681-40/3
SK 40	4	95	13-1681-40/4
SK 50	1	45	13-1681-50/1
SK 50	2	60	13-1681-50/2
SK 50	3	65	13-1681-50/3
SK 50	4	95	13-1681-50/4
SK 50	5	120	13-1681-50/5

**Zwischenhülsen DIN 69871 für MK-Werkzeuge
mit Anzugsgewinde**
Reducing adaptors DIN 69871 for MT tools with thread

- mit Anzugsgewinde DIN 6364 - with thread DIN 6364

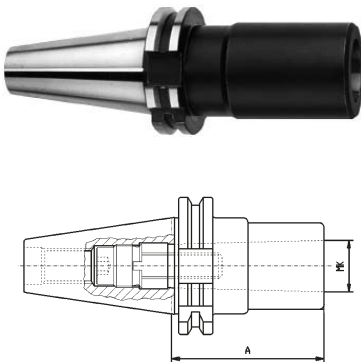

Gewuchtet G = 6,3 15.000 U/min.
Balanced G = 6,3 15.000 U/min.

Größe / Size	MK / MT	A mm	Art.-Nr. / Order no.
SK 40	1	50	13-1695-40/1
SK 40	2	50	13-1695-40/2
SK 40	3	70	13-1695-40/3
SK 40	4	95	13-1695-40/4
SK 50	1	45	13-1695-50/1
SK 50	2	60	13-1695-50/2
SK 50	3	65	13-1695-50/3
SK 50	4	70	13-1695-50/4
SK 50	5	100	13-1695-50/5

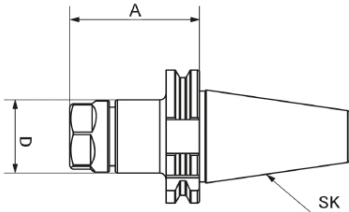

Gewuchtet G = 6,3 15.000 U/min.
Balanced G = 6,3 15.000 U/min.

Spannzangenfutter DIN 69871 ER
Collet chucks DIN 69871 ER

Größe / Size	Spannzange / Collet	A mm	D mm	Art.-Nr. / Order no.
SK 40	ER 16	63	28	● 13-7617-40-16
SK 40	ER 16	100	28	● 13-7617-40-16-100
SK 40	ER 16	160	28	● 13-7617-40-16-160
SK 40	ER 25	60	42	● 13-7617-40-25
SK 40	ER 25	100	42	● 13-7617-40-25-100
SK 40	ER 25	160	42	● 13-7617-40-25-160
SK 40	ER 32	70	50	● 13-7617-40-32
SK 40	ER 32	100	50	● 13-7617-40-32-100
SK 40	ER 32	160	50	▶ 13-7617-40-32-160
SK 40	ER 40	80	63	● 13-7617-40-40
SK 40	ER 40	100	63	● 13-7617-40-40-100
SK 40	ER 40	160	63	● 13-7617-40-40-160
SK 50	ER 32	70	50	● 13-7617-50-32
SK 50	ER 32	100	50	● 13-7617-50-32-100
SK 50	ER 32	160	50	▶ 13-7617-50-32-160
SK 50	ER 40	70	63	● 13-7617-50-40
SK 50	ER 40	100	63	● 13-7617-50-40-100
SK 50	ER 40	160	63	▶ 13-7617-50-40-160

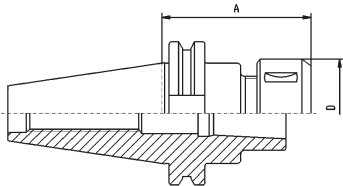

Gewuchtet G = 6,3 15.000 U/min.
Balanced G = 6,3 15.000 U/min.

Spannzangenfutter DIN 69871 OZ
Collet chucks DIN 69871 OZ

Größe / Size	Spannzange / Collet	A mm	D mm	Art.-Nr. / Order no.
SK 40	OZ16 (415E)	70	43	● 13-7645-40-16
SK 40	OZ25 (462E)	70	60	● 13-7645-40-25
SK 40	OZ32 (467E)	90	72	● 13-7645-40-32
SK 50	OZ25 (462E)	70	60	● 13-7645-50-25
SK 50	OZ32 (467E)	80	72	● 13-7645-50-32

Fräseraufnahme DIN 69871 mit Kühlmittelring für IKZ
Weldon chuck DIN 69871 with cooling agent ring

- mit Kühlmittelring für innere Kühlmittelzufuhr
- Aufnahmebohrung nach DIN 1835B (Weldon)
- with cooling agent ring for internal coolant supply
- according to DIN 1835B (Weldon)

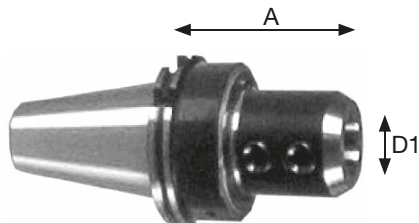

Größe / Size	D1 mm	A mm	Art.-Nr. / Order no.
SK 40	20	70	○ 09-FSKR-DIN-40-20
SK 40	25	100	○ 09-FSKR-DIN-40-25
SK 40	32	110	○ 09-FSKR-DIN-40-32
SK 40	40	120	○ 09-FSKR-DIN-40-40
SK 50	20	70	○ 09-FSKR-DIN-50-20
SK 50	25	100	○ 09-FSKR-DIN-50-25
SK 50	32	110	○ 09-FSKR-DIN-50-32
SK 50	40	120	○ 09-FSKR-DIN-50-40

Passende Reduzierhülsen siehe Seite 238
Suitable reduction sleeves see page 238



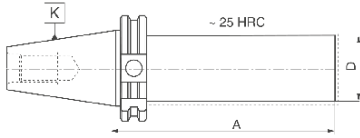

Rohlinge DIN 69871
Blanks DIN 69871

Größe / Size	D mm	A mm	Art.-Nr. / Order no.
40	40	280	13-2191-40-40-280
40	63	160	13-2191-40-63-160
40	63	250	13-2191-40-63-250
50	50	330	13-2191-50-50-330
50	97	315	13-2191-50-97-315

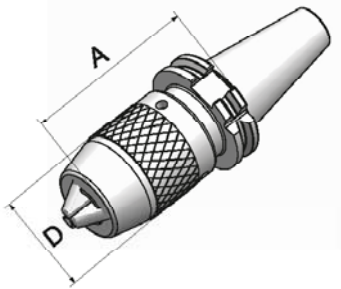

Bohrfutter DIN 69871
Drill chucks DIN 69871

- inkl. Hakenschlüssel

- incl. hook wrench

Größe / Size	Spannweite / Capacity mm	D mm	A mm	Rundlaufgenauigkeit / Runout mm	Art.-Nr. / Order no.
SK 40	1-13	50	95	0,05	13-7655-40-13
SK 40	3-16	57	100	0,05	13-7655-40-16
SK 50	3-16	55	115	0,05	13-7655-50-16

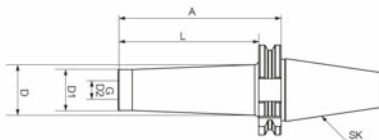

Gewuchtet G = 6,3 15.000 U/min.
Balanced G = 6,3 15.000 U/min.

Fräseraufnahme DIN 69871 für Einschraubfräser
Screw-in type milling arbors DIN 69871

Größe / Size	G	D2 mm	D1 mm	D mm	A mm	L mm	Art.-Nr. / Order no.
SK 40	M8	8,5	13	15	44	25	13-FASK40-M8-25
SK 40	M8	8,5	13	23	69	50	13-FASK40-M8-50
SK 40	M8	8,5	13	23	94	75	13-FASK40-M8-75
SK 40	M10	10,5	18	20	44	25	13-FASK40-M10-25
SK 40	M10	10,5	18	23	69	50	13-FASK40-M10-50
SK 40	M10	10,5	18	28	94	75	13-FASK40-M10-75
SK 40	M12	12,5	21	24	44	25	13-FASK40-M12-25
SK 40	M12	12,5	21	24	69	50	13-FASK40-M12-50
SK 40	M12	12,5	21	31	94	75	13-FASK40-M12-75
SK 40	M12	12,5	21	33	119	100	13-FASK40-M12-100
SK 40	M16	17	29	29	44	25	13-FASK40-M16-25
SK 40	M16	17	29	34	69	50	13-FASK40-M16-50
SK 40	M16	17	29	34	94	75	13-FASK40-M16-75
SK 40	M16	17	29	36	119	100	13-FASK40-M16-100
SK 40	M16	17	29	40	144	125	13-FASK40-M16-125

Weitere Größen siehe nächste Seite
Further sizes see next page



DIN 69871

11
11.4

DIN 69871 / DIN 69871

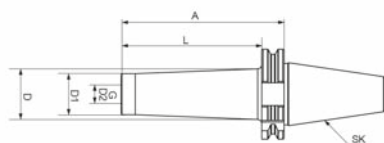

Gewuchtet G = 6,3 15.000 U/min.
Balanced G = 6,3 15.000 U/min.

Größe / Size	G	D2 mm	D1 mm	D mm	A mm	L mm	Art.-Nr. / Order no.
SK 50	M8	8,5	13	23	69	50	● 13-FASK50-M8-50
SK 50	M8	8,5	13	25	119	100	● 13-FASK50-M8-100
SK 50	M10	10,5	18	23	69	50	● 13-FASK50-M10-50
SK 50	M10	10,5	18	32	119	100	● 13-FASK50-M10-100
SK 50	M12	12,5	21	24	69	50	● 13-FASK50-M12-50
SK 50	M12	12,5	21	33	119	100	● 13-FASK50-M12-100
SK 50	M12	12,5	21	40	169	150	● 13-FASK50-M12-150
SK 50	M16	17	29	34	69	50	● 13-FASK50-M16-50
SK 50	M16	17	29	36	119	100	● 13-FASK50-M16-100
SK 50	M16	17	29	43	169	150	● 13-FASK50-M16-150



Schrumpffutter DIN 69871 AD/B
Shrink chuck DIN 69871 AD/B

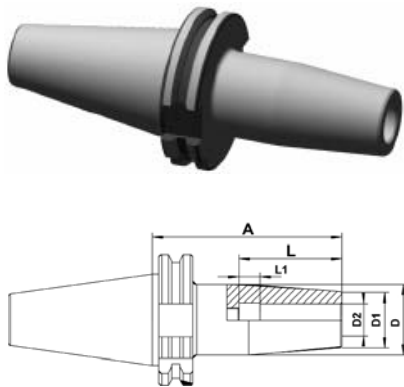

Gewuchtet G = 2,5 25.000 U/min.
Balanced G = 2,5 25.000 U/min.

Größe / Size	D2 mm	D1 mm	D mm	L mm	L1 mm	A mm	Art.-Nr. / Order no.
SK 40	3	10	20	15	-	80	▶ 13-SHFSK40-3-80
SK 40	3	10	20	15	-	120	▶ 13-SHFSK40-3-120
SK 40	3	10	20	15	-	160	▶ 13-SHFSK40-3-160
SK 40	4	15	22	15	-	80	▶ 13-SHFSK40-4-80
SK 40	4	15	22	15	-	120	▶ 13-SHFSK40-4-120
SK 40	4	15	22	15	-	160	▶ 13-SHFSK40-4-160
SK 40	5	15	22	20	-	80	▶ 13-SHFSK40-5-80
SK 40	5	15	22	20	-	120	▶ 13-SHFSK40-5-120
SK 40	5	15	22	20	-	160	▶ 13-SHFSK40-5-160
SK 40	6	20	27	36	10	80	▶ 13-SHFSK40-6-80
SK 40	6	20	27	36	10	120	▶ 13-SHFSK40-6-120
SK 40	6	20	27	36	10	160	▶ 13-SHFSK40-6-160
SK 40	8	20	27	36	10	80	▶ 13-SHFSK40-8-80
SK 40	8	20	27	36	10	120	▶ 13-SHFSK40-8-120
SK 40	8	20	27	36	10	160	▶ 13-SHFSK40-8-160
SK 40	10	24	31	41	10	80	▶ 13-SHFSK40-10-80
SK 40	10	24	31	41	10	120	▶ 13-SHFSK40-10-120
SK 40	10	24	31	41	10	160	▶ 13-SHFSK40-10-160
SK 40	12	24	31	47	10	80	▶ 13-SHFSK40-12-80
SK 40	12	24	31	47	10	120	▶ 13-SHFSK40-12-120
SK 40	12	24	31	47	10	160	▶ 13-SHFSK40-12-160
SK 40	14	27	34	47	10	80	▶ 13-SHFSK40-14-80
SK 40	14	27	34	47	10	120	▶ 13-SHFSK40-14-120
SK 40	14	27	34	47	10	160	▶ 13-SHFSK40-14-160
SK 40	16	27	34	50	10	80	▶ 13-SHFSK40-16-80
SK 40	16	27	34	50	10	120	▶ 13-SHFSK40-16-120
SK 40	16	27	34	50	10	160	▶ 13-SHFSK40-16-160
SK 40	18	33	40	50	10	80	▶ 13-SHFSK40-18-80
SK 40	18	33	40	50	10	120	▶ 13-SHFSK40-18-120
SK 40	18	33	40	50	10	160	▶ 13-SHFSK40-18-160
SK 40	20	33	40	52	10	80	▶ 13-SHFSK40-20-80
SK 40	20	33	40	52	10	120	▶ 13-SHFSK40-20-120
SK 40	20	33	40	52	10	160	▶ 13-SHFSK40-20-160
SK 40	25	44	53	58	10	100	▶ 13-SHFSK40-25-100
SK 40	25	44	53	58	10	120	▶ 13-SHFSK40-25-120
SK 40	25	44	53	58	10	160	▶ 13-SHFSK40-25-160
SK 40	32	44	53	62	10	100	▶ 13-SHFSK40-32-100
SK 40	32	44	53	62	10	120	▶ 13-SHFSK40-32-120
SK 40	32	44	53	62	10	160	▶ 13-SHFSK40-32-160

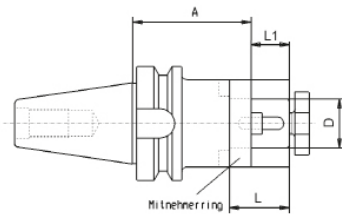

Gewuchtet G = 6,3 15.000 U/min.
Balanced G = 6,3 15.000 U/min.

Kombi-Fräseraufsteckdorne MAS BT
Combination shell mill adaptors MAS BT

Größe / Size	D mm	A mm	L mm	L1 mm	Art.-Nr. / Order no.
BT 40	16	55	27	17	● 13-7361-40-16
BT 40	22	55	32	19	● 13-7361-40-22
BT 40	27	55	33	21	● 13-7361-40-27
BT 40	32	60	38	24	● 13-7361-40-32
BT 40	40	60	41	27	● 13-7361-40-40
BT 50	16	70	27	17	● 13-7361-50-16
BT 50	22	70	31	19	● 13-7361-50-22
BT 50	27	70	33	21	● 13-7361-50-27
BT 50	32	70	38	24	● 13-7361-50-32
BT 50	40	70	41	27	● 13-7361-50-40
BT 50	50	70	45	30	● 13-7361-50-50*

* Ungewuchtet
* Unbalanced

Messerkopf-Aufnahmen MAS BT
Face mill holders MAS BT

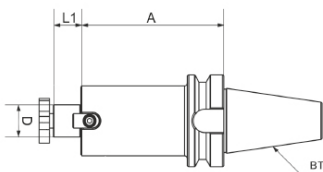

Gewuchtet G = 6,3 15.000 U/min.
Balanced G = 6,3 15.000 U/min.

Größe / Size	D mm	A mm	L1 mm	Art.-Nr. / Order no.
BT 40	16	40	17	● 13-7388-40-16
BT 40	16	100	17	▶ 13-7388-40-16-100
BT 40	22	45	19	● 13-7388-40-22
BT 40	22	100	19	▶ 13-7388-40-22-100
BT 40	27	40	21	● 13-7388-40-27
BT 40	27	100	21	▶ 13-7388-40-27-100
BT 40	32	50	24	● 13-7388-40-32
BT 40	32	100	24	▶ 13-7388-40-32-100
BT 40	40	50	27	● 13-7388-40-40
BT 40	40	100	27	▶ 13-7388-40-40-100
BT 50	22	40	19	● 13-7388-50-22
BT 50	22	100	19	▶ 13-7388-50-22-100
BT 50	27	40	21	● 13-7388-50-27
BT 50	27	100	21	▶ 13-7388-50-27-100
BT 50	32	50	24	● 13-7388-50-32
BT 50	32	100	24	▶ 13-7388-50-32-100
BT 50	40	50	27	● 13-7388-50-40
BT 50	40	100	27	▶ 13-7388-50-40-100
BT 50	50	78	30	● 13-7388-50-50*

* Ungewuchtet
* Unbalanced

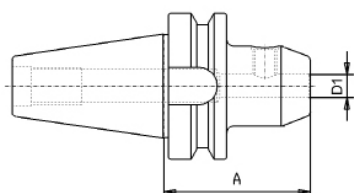

Gewuchtet G = 6,3 15.000 U/min.
Balanced G = 6,3 15.000 U/min.

Flächenspannfutter WELDON MAS BT End mill adaptors WELDON MAS BT

Größe / Size	D1 mm	A mm	Art.-Nr. / Order no.
BT 40	6	50	13-7624-40-6-50
BT 40	6	100	13-7624-40-6-100
BT 40	8	50	13-7624-40-8-50
BT 40	8	100	13-7624-40-8-100
BT 40	10	63	13-7624-40-10-63
BT 40	10	100	13-7624-40-10-100
BT 40	12	63	13-7624-40-12-63
BT 40	12	100	13-7624-40-12-100
BT 40	14	63	13-7624-40-14-63
BT 40	16	63	13-7624-40-16-63
BT 40	16	100	13-7624-40-16-100
BT 40	18	63	13-7624-40-18-63
BT 40	20	63	13-7624-40-20-63
BT 40	20	100	13-7624-40-20-100
BT 40	25	90	13-7624-40-25-90
BT 40	32	100	13-7624-40-32-100
BT 40	40	120	13-7624-40-40-105
BT 50	6	63	13-7624-50-6-63
BT 50	8	63	13-7624-50-8-63
BT 50	10	63	13-7624-50-10-63
BT 50	12	80	13-7624-50-12-80
BT 50	14	80	13-7624-50-14-80
BT 50	16	80	13-7624-50-16-80
BT 50	20	80	13-7624-50-20-80
BT 50	25	100	13-7624-50-25-100
BT 50	32	105	13-7624-50-32-105
BT 50	40	110	13-7624-50-40-115

Bohrfutteraufnahmen MAS BT Drill chuck adaptors MAS BT

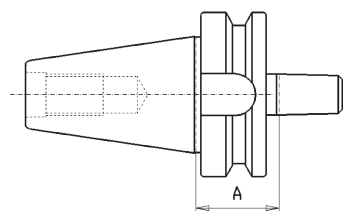

Gewuchtet G = 6,3 15.000 U/min.
Balanced G = 6,3 15.000 U/min.

Größe / Size	Kegel / Taper	A mm	Art.-Nr. / Order no.
BT 40	B12	32	13-5373-40-B12
BT 40	B16	32	13-5373-40-B16
BT 50	B16	45	13-5373-50-B16
BT 50	B18	45	13-5373-50-B18



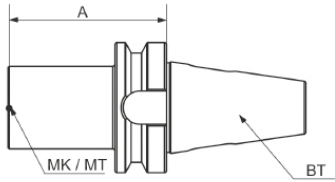

Gewuchtet G = 6,3 15.000 U/min.
Balanced G = 6,3 15.000 U/min.

Zwischenhülsen MAS BT für MK-Werkzeuge mit Austreiblappen
Reducing adaptors MAS BT for MT tools with tang

Größe / Size	MK / MT	A mm	Art.-Nr. / Order no.
BT 40	1	50	● 13-1661-40/1
BT 40	2	50	● 13-1661-40/2
BT 40	3	70	● 13-1661-40/3
BT 40	4	95	● 13-1661-40/4
BT 50	1	45	● 13-1661-50/1
BT 50	2	60	● 13-1661-50/2
BT 50	3	65	● 13-1661-50/3
BT 50	4	95	● 13-1661-50/4
BT 50	5	120	● 13-1661-50/5

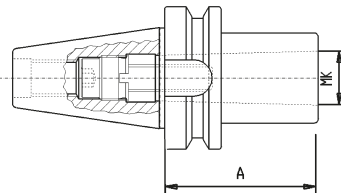

Gewuchtet G = 6,3 15.000 U/min.
Balanced G = 6,3 15.000 U/min.

Zwischenhülsen MAS BT für MK-Werkzeuge mit Anzugsgewinde
Reducing adaptors MAS BT for MT tools with thread

- mit Anzugsgewinde DIN 6364 - with thread DIN 6364

Größe / Size	MK / MT	A mm	Art.-Nr. / Order no.
BT 40	1	50	● 13-1694-40/1
BT 40	2	50	● 13-1694-40/2
BT 40	3	70	● 13-1694-40/3
BT 40	4	95	● 13-1694-40/4
BT 50	1	45	* 13-1694-50/1
BT 50	2	60	● 13-1694-50/2
BT 50	3	65	● 13-1694-50/3
BT 50	4	70	● 13-1694-50/4
BT 50	5	120	● 13-1694-50/5

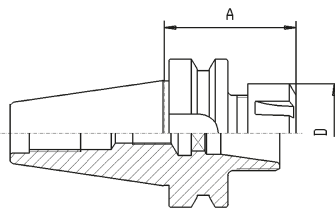

Gewuchtet G = 6,3 15.000 U/min.
Balanced G = 6,3 15.000 U/min.

Spannzangenfutter MAS BT ER
Collet chucks MAS BT ER

Größe / Size	Spannzange / Collet	A mm	D mm	Art.-Nr. / Order no.
BT 40	ER 16	63	32	● 13-7626-40-16
BT 40	ER 25	70	42	● 13-7626-40-25
BT 40	ER 32	70	50	● 13-7626-40-32
BT 40	ER 40	80	63	● 13-7626-40-40
BT 50	ER 32	70	50	● 13-7626-50-32
BT 50	ER 40	80	63	● 13-7626-50-40

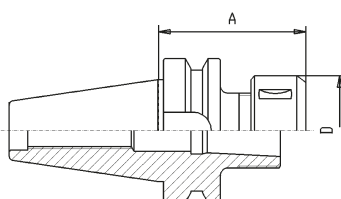

Gewuchtet G = 6,3 15.000 U/min.
Balanced G = 6,3 15.000 U/min.

Spannzangenfutter MAS BT OZ
Collet chucks MAS BT OZ

Größe / Size	Spannzange / Collet	A mm	D mm	Art.-Nr. / Order no.
BT 40	OZ16 (415E)	70	43	▶ 13-7606-40-16
BT 40	OZ25 (462E)	70	60	● 13-7606-40-25
BT 40	OZ32 (467E)	90	72	● 13-7606-40-32
BT 50	OZ25 (462E)	85	60	▶ 13-7606-50-25
BT 50	OZ32 (467E)	90	72	▶ 13-7606-50-32

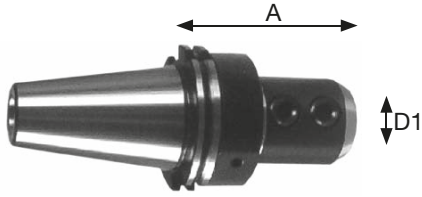

Fräseraufnahme MAS BT mit Kühlmittelring für IKZ
Weldon chuck MAS BT with cooling agent ring

- mit Kühlmittelring für innere Kühlmittelzufuhr
- Aufnahmebohrung nach Weldon DIN 1835B
- with cooling agent ring for internal coolant supply
- according to DIN 1835B

Größe / Size	D1 mm	A mm	Art.-Nr. / Order no.
BT 40	20	70	09-FSKR-BT-40-20
BT 40	25	100	09-FSKR-BT-40-25
BT 40	32	110	09-FSKR-BT-40-32
BT 40	40	120	09-FSKR-BT-40-40
BT 50	20	70	09-FSKR-BT-50-20
BT 50	25	100	09-FSKR-BT-50-25
BT 50	32	110	09-FSKR-BT-50-32
BT 50	40	120	09-FSKR-BT-50-40

Passende Reduzierhülsen siehe Seite 238
Suitable reduction sleeves see page 238



Bohrfutter MAS BT
Drill chucks MAS BT

- inkl. Hakenschlüssel
- incl. hook wrench

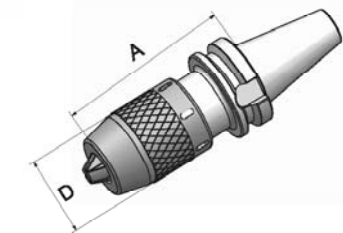

Größe / Size	Spannweite / Capacity mm	D mm	A mm	Rundlaufgenauigkeit / Runout mm	Art.-Nr. / Order no.
BT 40	1-13	50	95	0,05	13-7656-40-13
BT 40	3-16	57	100	0,05	13-7656-40-16



Rohlinge MAS BT
Blanks MAS BT

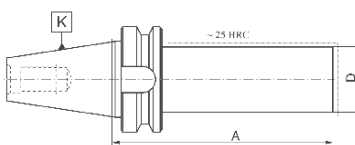

Größe / Size	D mm	A mm	Art.-Nr. / Order no.
BT 40	40	280	13-2192-40-40-280
BT 40	63	250	13-2192-40-63-250
BT 50	50	330	13-2192-50-50-330
BT 50	97	315	13-2192-50-97-315



Fräseraufnahme MAS BT für Einschraubfräser
Screw-in type milling arbors MAS BT

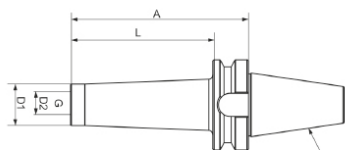

Gewuchtet G = 6,3 15.000 U/min.
Balanced G = 6,3 15.000 U/min.

Größe / Size	G	D2 mm	D1 mm	D mm	A mm	L mm	Art.-Nr. / Order no.
BT 40	M8	8,5	13	23	77	50	● 13-FABT40-M8-50
BT 40	M8	8,5	13	25	120	100	● 13-FABT40-M8-100
BT 40	M10	10,5	18	20	52	25	● 13-FABT40-M10-25
BT 40	M10	10,5	18	23	77	50	● 13-FABT40-M10-50
BT 40	M10	10,5	18	28	102	75	● 13-FABT40-M10-75
BT 40	M10	10,5	18	32	127	100	● 13-FABT40-M10-100
BT 40	M12	12,5	21	24	52	25	● 13-FABT40-M12-25
BT 40	M12	12,5	21	28	77	50	● 13-FABT40-M12-50
BT 40	M12	12,5	21	31	102	75	● 13-FABT40-M12-75
BT 40	M12	12,5	21	31	138	100	● 13-FABT40-M12-100
BT 40	M16	17	29	29	52	25	● 13-FABT40-M16-25
BT 40	M16	17	29	34	77	50	● 13-FABT40-M16-50
BT 40	M16	17	29	34	102	75	● 13-FABT40-M16-75
BT 40	M16	17	29	41	138	100	● 13-FABT40-M16-100
BT 40	M16	17	29	44	152	125	● 13-FABT40-M16-125
BT 40	M16	17	29	50	188	150	● 13-FABT40-M16-150
BT 50	M8	8,5	13	23	88	50	● 13-FABT50-M8-50
BT 50	M8	8,5	13	25	138	100	● 13-FABT50-M8-100
BT 50	M8	8,5	13	30	188	150	● 13-FABT50-M8-150
BT 50	M10	10,5	18	23	88	50	● 13-FABT50-M10-50
BT 50	M10	10,5	18	32	138	100	● 13-FABT50-M10-100
BT 50	M10	10,5	18	37	188	150	● 13-FABT50-M10-150
BT 50	M12	12,5	21	24	88	50	● 13-FABT50-M12-50
BT 50	M12	12,5	21	33	138	100	● 13-FABT50-M12-100
BT 50	M12	12,5	21	40	188	150	● 13-FABT50-M12-150
BT 50	M16	17	29	34	88	50	● 13-FABT50-M16-50
BT 50	M16	17	29	36	138	100	● 13-FABT50-M16-100
BT 50	M16	17	29	43	188	150	● 13-FABT50-M16-150

Schrumpffutter MAS BT
Shrink chuck MAS BT

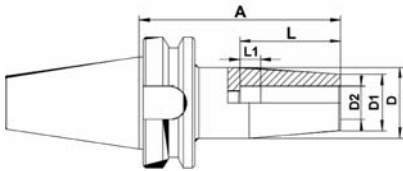

Gewuchtet G = 2,5 25.000 U/min.
Balanced G = 2,5 25.000 U/min.

Größe / Size	D2 mm	D1 mm	D mm	L mm	L1 mm	A mm	Art.-Nr. / Order no.
BT 40	3	10	20	15	-	90	13-SHFBT40-3-90
BT 40	3	10	20	15	-	120	13-SHFBT40-3-120
BT 40	3	10	20	15	-	160	13-SHFBT40-3-160
BT 40	4	15	22	15	-	90	13-SHFBT40-4-90
BT 40	4	15	22	15	-	120	13-SHFBT40-4-120
BT 40	4	15	22	15	-	160	13-SHFBT40-4-160
BT 40	5	15	22	20	-	90	13-SHFBT40-5-90
BT 40	5	15	22	20	-	120	13-SHFBT40-5-120
BT 40	5	15	22	20	-	160	13-SHFBT40-5-160
BT 40	6	20	27	36	10	90	13-SHFBT40-6-90
BT 40	6	20	27	36	10	120	13-SHFBT40-6-120
BT 40	6	20	27	36	10	160	13-SHFBT40-6-160
BT 40	8	20	27	36	10	90	13-SHFBT40-8-90
BT 40	8	20	27	36	10	120	13-SHFBT40-8-120
BT 40	8	20	27	36	10	160	13-SHFBT40-8-160
BT 40	10	24	31	41	10	90	13-SHFBT40-10-90
BT 40	10	24	31	41	10	120	13-SHFBT40-10-120
BT 40	10	24	31	41	10	160	13-SHFBT40-10-160
BT 40	12	24	31	47	10	90	13-SHFBT40-12-90
BT 40	12	24	31	47	10	120	13-SHFBT40-12-120
BT 40	12	24	31	47	10	160	13-SHFBT40-12-160
BT 40	14	27	34	47	10	90	13-SHFBT40-14-90
BT 40	14	27	34	47	10	120	13-SHFBT40-14-120
BT 40	14	27	34	47	10	160	13-SHFBT40-14-160
BT 40	16	27	34	50	10	90	13-SHFBT40-16-90
BT 40	16	27	34	50	10	120	13-SHFBT40-16-120
BT 40	16	27	34	50	10	160	13-SHFBT40-16-160
BT 40	18	33	40	50	10	90	13-SHFBT40-18-90
BT 40	18	33	40	50	10	120	13-SHFBT40-18-120
BT 40	18	33	40	50	10	160	13-SHFBT40-18-160
BT 40	20	33	40	52	10	90	13-SHFBT40-20-90
BT 40	20	33	40	52	10	120	13-SHFBT40-20-120
BT 40	20	33	40	52	10	160	13-SHFBT40-20-160
BT 40	25	44	53	58	10	100	13-SHFBT40-25-100
BT 40	25	44	53	58	10	120	13-SHFBT40-25-120
BT 40	25	44	53	58	10	160	13-SHFBT40-25-160
BT 40	32	44	53	62	10	100	13-SHFBT40-32-100
BT 40	32	44	53	62	10	120	13-SHFBT40-32-120
BT 40	32	44	53	62	10	160	13-SHFBT40-32-160

Aufnahmen mit Zylinderschaft Straight shank tooling

11
11.6

Spannzangenfutter ER mit Zylinderschaft und Minimutter Collet chucks ER with cylindrical shank and mini nut

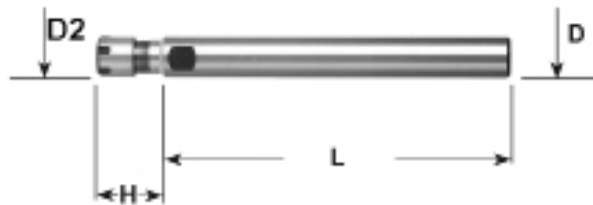

D mm	Spannzange / Collet	L mm	D2 mm	H mm	Art.-Nr. / Order no.
12	ER 8	100	12	23	● 13-7812-12-8M-100
12	ER 11	100	16	26	● 13-7812-12-11M-100
12	ER 11	140	16	28	● 13-7812-12-11M-140
12	ER 16	80	22	35	● 13-7812-12-16M-80
16	ER 11	100	16	19	● 13-7812-16-11M-100
16	ER 11	130	16	19	● 13-7812-16-11M-130
16	ER 11	160	16	18	● 13-7812-16-11M-160
16	ER 16	100	22	35	● 13-7812-16-16M-100
16	ER 16	130	22	35	● 13-7812-16-16M-130
16	ER 16	160	22	33	● 13-7812-16-16M-160
20	ER 11	100	16	19	● 13-7812-20-11M-100
20	ER 11	130	16	19	● 13-7812-20-11M-130
20	ER 16	100	22	31	● 13-7812-20-16M-100
20	ER 16	130	22	31	● 13-7812-20-16M-130
20	ER 16	165	22	22	● 13-7812-20-16M-160
20	ER 20	130	28	45	● 13-7812-20-20M-130
20	ER 20	160	28	45	● 13-7812-20-20M-160
20	ER 20	200	28	45	● 13-7812-20-20M-200
25	ER 11	160	16	28	● 13-7812-25-11M-160
25	ER 16	100	22	25	● 13-7812-25-16M-100
25	ER 16	130	22	25	● 13-7812-25-16M-130
25	ER 16	163	22	22	● 13-7812-25-16M-160
25	ER 20	130	28	40	● 13-7812-25-20M-130
25	ER 20	160	28	40	● 13-7812-25-20M-160

Aufnahmen mit Zylinderschaft Straight shank tooling

Spannzangenfutter ER mit Zylinderschaft u. Standardmutter Collet chucks ER with cylindrical shank and standard nut

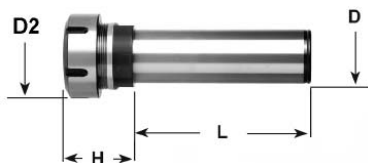

D mm	Spannzange / Collet	L mm	D2 mm	H mm	Art.-Nr. / Order no.
20	ER 25	50	42	42	● 13-7812-20-25-50
20	ER 25	100	42	42	● 13-7812-20-25-100
20	ER 25	130	42	40	● 13-7812-20-25-130
20	ER 25	160	42	46	● 13-7812-20-25-160
20	ER 32	100	50	47	● 13-7812-20-32-100
20	ER 32	130	50	53	● 13-7812-20-32-130
20	ER 32	160	50	53	● 13-7812-20-32-160
25	ER 20	160	28	45	● 13-7812-25-20-160
25	ER 25	50	42	48	● 13-7812-25-25-50
25	ER 25	100	42	45	● 13-7812-25-25-100
25	ER 25	160	42	45	● 13-7812-25-25-160
25	ER 32	50	50	50	● 13-7812-25-32-50
25	ER 32	100	50	50	● 13-7812-25-32-100
25	ER 32	130	50	53	● 13-7812-25-32-130
25	ER 32	160	50	48	● 13-7812-25-32-160
25	ER 40	60	63	55	● 13-7812-25-40-60
32	ER 25	100	42	27	● 13-7812-32-25-100
32	ER 25	160	42	48	* 13-7812-32-25-160
32	ER 32	50	50	50	● 13-7812-32-32-50
32	ER 32	100	50	50	● 13-7812-32-32-100
32	ER 32	130	50	42	● 13-7812-32-32-130
32	ER 32	160	50	48	● 13-7812-32-32-160
32	ER 40	70	63	35	● 13-7812-32-40-70
32	ER 40	130	63	60	● 13-7812-32-40-130
40	ER 32	80	50	45	● 13-7812-40-32-80
40	ER 32	135	50	50	● 13-7812-40-32-130
40	ER 32	160	50	50	● 13-7812-40-32-160
40	ER 40	130	63	50	● 13-7812-40-40-130
40	ER 40	160	63	50	● 13-7812-40-40-160
50	ER 40	120	63	35	● 13-7812-50-40-120
50	ER 40	160	63	35	● 13-7812-50-40-160

Spannzangenfutter Typ Erickson mit Zylinderschaft Collet chucks type Erickson with cylindrical shank



D mm	Spannzange / Collet	L mm	H mm	D2 mm	Art.-Nr. / Order no.
8	412E (DK-S)	100	32	10	▶ 13-6612-8-S-100
12	416E (DK30)	76	36	14	▶ 13-6612-12-30-76
12	416E (DK30)	140	36	14	▶ 13-6612-12-30-140
20	417E (DK20)	76	44	21	▶ 13-6612-20-20-76
20	417E (DK20)	140	44	21	▶ 13-6612-20-20-140
25	418E (DK10)	76	49,4	27	▶ 13-6612-25-10-76
25	418E (DK10)	140	49,4	27	▶ 13-6612-25-10-140

Passende Spannzangen siehe Seite 197
Suitable collets see page 197

Aufnahmen mit Zylinderschaft Straight shank tooling

11

11.6

Aufnahmen mit Zylinderschaft / Straight shank tooling



Reduzierhülsen für Fräseraufnahmen mit IKZ Reduction sleeves f. Weldon chucks with coolant agent ring

D mm	D1 mm	Art.-Nr. / Order no.
25	16	09-RZ-25-16
25	20	09-RZ-25-20
32	20	09-RZ-32-20
32	25	09-RZ-32-25
40	20	09-RZ-40-20
40	25	09-RZ-40-25
40	32	09-RZ-40-32

Pendelhalter mit Zylinderschaft Floating chucks with cylindrical shank



- mit einstellbarem Radialspiel
- Einstellbereiche: Freipendeln und Parallelpendeln
- Federkraft, Zentrierkraft und Freipendeln einstellbar
- with adjustable radial floating movement
- application: Free and parallel floating
- spring force, centering force and floating movement adjustable

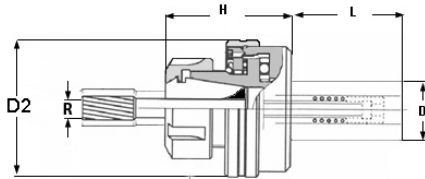

Spannzange / Collet	D mm	H mm	D2 mm	L mm	R mm	Art.-Nr. / Order no.
ER 11	16	40	42	46	1	09-PHZ-11-16
ER 11	20	40	42	46	1	09-PHZ-11-20
ER 16	16	44	42	46	1	09-PHZ-16-16
ER 16	25	44	42	46	1	09-PHZ-16-25
ER 20	16	50	50	46	1	09-PHZ-20-16
ER 20	20	50	50	46	1	09-PHZ-20-20
ER 20	25	50	50	46	1	09-PHZ-20-25
ER 25	20	53	57	46	1	09-PHZ-25-20
ER 25	25	53	57	46	1	09-PHZ-25-25
ER 32	25	58	69	50	1,5	09-PHZ-32-25
ER 32	32	58	69	50	1,5	09-PHZ-32-32
ER 40	25	64	79	50	1,5	09-PHZ-40-25
ER 40	32	64	79	50	1,5	09-PHZ-40-32

Sägeblattaufnahmen Saw-blade holders



- zur präzisen Aufnahme von Sägeblättern in Flächenspannfuttern
- Lieferumfang: Aufnahme, Zwischenscheibe und Spannschraube
- for precision use of saw blades in Weldon chucks
- scope of supply: saw blade holder, intermediate disc, clamping screw

Sägeblatt-Ø / Saw-blade-Ø mm	L mm	D mm	Aufnahme-Ø / Mounting-Ø mm	Art.-Nr. / Order no.
20	94	20	5	15-00S2020
25	104	20	8	15-00S2025
32	110	20	8	15-00S2032
40	114	20	10	15-00S2040
50	141	25	13	15-00S2550
63	141	25	16	15-00S2563
80	160	25	22	15-00S2580
100	160	25	22	15-00S25100



Räumwerkzeughalter mit Zylinderschaft
Broach tool holders with cylindrical shank

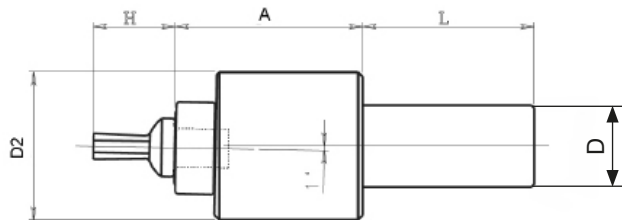

D mm	D2 mm	L mm	A mm	H mm	Aufnahme / Mounting	Art.-Nr. / Order no.
16	44	50	46	25	Ø 12	▶ 47-RHV-D16-12
20	58	50	76	40	Ø 16	▶ 47-RHV-D20-16

Passende Räumstempel siehe Seiten 175 - 177
Suitable cutters see pages 175 - 177

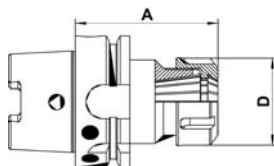

Gewuchtet G = 6,3 25.000 U/min.
Balanced G = 6,3 2.000 U/min.

Spannzangenfutter ER - Form A Collet chucks ER - form A

Größe / Size	Für Spannzange / For collet	D mm	A mm	Art.-Nr. / Order no.
HSK-A 63	ER16 (1-10)	28	100	● 17-SF63A-ER16-100
HSK-A 63	ER16 (1-10)	28	160	▶ 17-SF63A-ER16-160
HSK-A 63	ER25 (2-16)	42	100	● 17-SF63A-ER25-100
HSK-A 63	ER25 (2-16)	42	160	▶ 17-SF63A-ER25-160
HSK-A 63	ER32 (2-20)	50	100	● 17-SF63A-ER32-100
HSK-A 63	ER32 (2-20)	50	160	▶ 17-SF63A-ER32-160
HSK-A 63	ER40 (3-26)	63	120	● 17-SF63A-ER40-120
HSK-A 63	ER40 (3-26)	63	160	▶ 17-SF63A-ER40-160

Flächenspannfutter WELDON - Form A End mill adaptors WELDON - form A

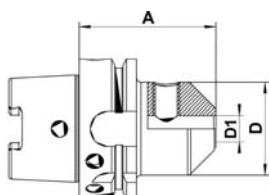

Gewuchtet G = 6,3 15.000 U/min.
Balanced G = 6,3 15.000 U/min.

Größe / Size	D1 mm	D mm	A mm	Art.-Nr. / Order no.
HSK-A 63	6	25	65	● 17-WE63A-6-65
HSK-A 63	6	25	100	▶ 17-WE63A-6-100
HSK-A 63	8	28	65	● 17-WE63A-8-65
HSK-A 63	8	28	100	▶ 17-WE63A-8-100
HSK-A 63	10	35	65	● 17-WE63A-10-65
HSK-A 63	10	35	100	▶ 17-WE63A-10-100
HSK-A 63	12	42	80	● 17-WE63A-12-80
HSK-A 63	12	42	100	▶ 17-WE63A-12-100
HSK-A 63	16	48	80	● 17-WE63A-16-80
HSK-A 63	16	48	100	▶ 17-WE63A-16-100
HSK-A 63	18	50	80	● 17-WE63A-18-80
HSK-A 63	20	52	80	● 17-WE63A-20-80
HSK-A 63	20	52	100	▶ 17-WE63A-20-100
HSK-A 63	25	65	110	● 17-WE63A-25-110
HSK-A 63	32	72	110	● 17-WE63A-32-110
HSK-A 63	40	80	125	● 17-WE63A-40-125

Kombi-Fräseraufsteckdorne DIN 6358 - Form A Combination shell mill adaptors DIN 6358 - form A

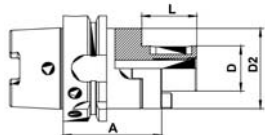

Gewuchtet G = 6,3 15.000 U/min.
Balanced G = 6,3 15.000 U/min.

Größe / Size	D mm	D2 mm	A mm	L mm	Art.-Nr. / Order no.
HSK-A 63	16	32	60	27	● 17-KD63A-16-60
HSK-A 63	16	32	100	27	● 17-KD63A-16-100
HSK-A 63	22	40	60	31	● 17-KD63A-22-60
HSK-A 63	22	40	100	31	● 17-KD63A-22-100
HSK-A 63	27	48	60	33	● 17-KD63A-27-60
HSK-A 63	27	48	100	33	● 17-KD63A-27-100
HSK-A 63	32	58	60	38	● 17-KD63A-32-65
HSK-A 63	32	58	100	38	● 17-KD63A-32-100
HSK-A 63	40	70	70	41	● 17-KD63A-40-70

Werkzeugaufnahmen mit HSK auch in Form C, E und F lieferbar
HSK tool holders are also available in form C, E and F

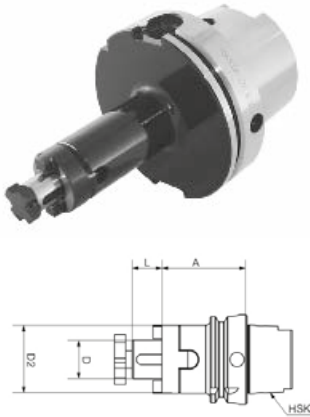

Gewuchtet G = 6,3 15.000 U/min.
Balanced G = 6,3 15.000 U/min.

Messerkopf-Aufnahmen DIN 6357 - Form A Shell mill holders DIN 6357 - form A

- mit vergrößertem Bunddurchmesser - with enlarged collar diameter

Größe / Size	D mm	D2 mm	L mm	A mm	Art.-Nr. / Order no.
HSK-A 63	16	38	17	50	17-MS63A-16-50
HSK-A 63	16	38	17	100	17-MS63A-16-100
HSK-A 63	22	48	19	50	17-MS63A-22-50
HSK-A 63	22	48	19	100	17-MS63A-22-100
HSK-A 63	27	58	21	55	17-MS63A-27-55
HSK-A 63	27	58	21	100	17-MS63A-27-100
HSK-A 63	32	78	24	60	17-MS63A-32-60
HSK-A 63	32	78	24	100	17-MS63A-32-100
HSK-A 63	40	88	27	60	17-MS63A-40-60
HSK-A 63	40	88	27	100	17-MS63A-40-100

Einsatzhülsen für MK-Werkzeuge mit Austreibblappen - Form A Adaptors for morse taper tools with tang - form A

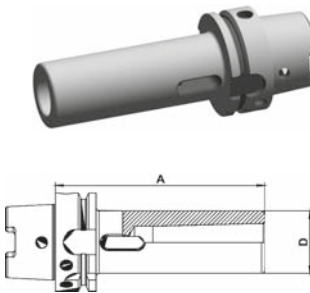

Gewuchtet G = 6,3 15.000 U/min.
Balanced G = 6,3 15.000 U/min.

Größe / Size	MK / MT	D mm	A mm	Art.-Nr. / Order no.
HSK-A 63	1	25	100	17-EH63A-MK1
HSK-A 63	2	32	120	17-EH63A-MK2
HSK-A 63	3	40	140	17-EH63A-MK3
HSK-A 63	4	48	160	17-EH63A-MK4

Bohrfutter - Form A Drill chucks - form A

- inkl. Hakenschlüssel - incl. hook wrench

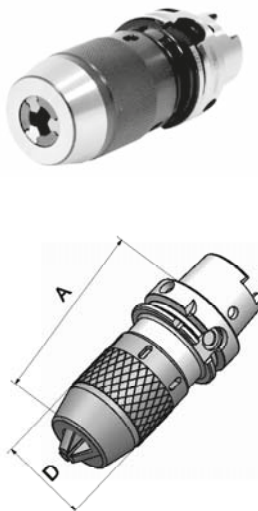

Größe / Size	Spannweite / Capacity mm	D mm	A mm	Rundlaufgenauigkeit / Runout mm	Art.-Nr. / Order no.
HSK-A 63	1-13	48	150	0,08	13-7658-63-13
HSK-A 63	3-16	53	155	0,08	13-7658-63-16

Werkzeugaufnahmen mit HSK auch in Form C, E und F lieferbar
HSK tool holders are also available in form C, E and F



DIN 69893 HSK - A DIN 69893 HSK - A

11
11.7

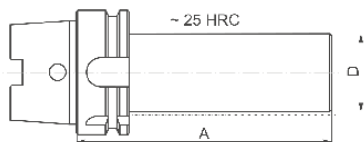

Bohrstangenrohling - Form A Blank adaptor - form A

Größe / Size	D mm	A mm	Art.-Nr. / Order no.
HSK-A 63	63	150	● 17-BR63A-63-150
HSK-A 63	65	68	* 17-BR63A-65-68

Prüfdorn - Form A Test arbor - form A



Größe / Size	D mm	A mm	Art.-Nr. / Order no.
HSK-A 63	40	300	● 17-PD63A-40-300

Fräseraufnahme Form A für Einschraubfräser Screw-in type milling arbors form A

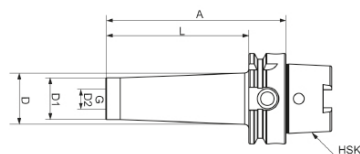

Größe / Size	G	D2 mm	D1 mm	D mm	A mm	L mm	Art.-Nr. / Order no.
HSK-A 63	M10	10,5	18	23	76	50	● 17-FA63A-M10-50
HSK-A 63	M10	10,5	18	32	126	100	● 17-FA63A-M10-100
HSK-A 63	M12	12,5	21	24	51	25	● 17-FA63A-M12-25
HSK-A 63	M12	12,5	21	24	76	50	● 17-FA63A-M12-50
HSK-A 63	M12	12,5	21	31	101	75	● 17-FA63A-M12-75
HSK-A 63	M12	12,5	21	33	126	100	● 17-FA63A-M12-100
HSK-A 63	M16	17	29	29	51	25	● 17-FA63A-M16-25
HSK-A 63	M16	17	29	34	76	50	● 17-FA63A-M16-50
HSK-A 63	M16	17	29	34	101	75	● 17-FA63A-M16-75
HSK-A 63	M16	17	29	36	126	100	● 17-FA63A-M16-100

Gewuchtet G = 6,3 15.000 U/min.
Balanced G = 6,3 15.000 U/min.

Werkzeugaufnahmen mit HSK auch in Form C, E und F lieferbar
HSK tool holders are also available in form C, E and F



Schrumpffutter - Form A
Shrink chuck - form A

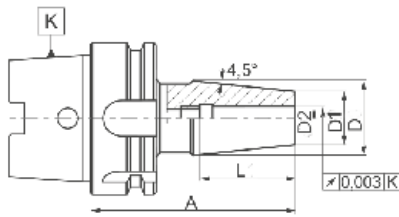

Gewuchtet G = 6,3 15.000 U/min.
Balanced G = 6,3 15.000 U/min.

Größe / Size	D2 mm	D1 mm	D mm	L mm	A mm	Art.-Nr. / Order no.
HSK-A 63	3	10	18	36	80	17-SHF63A-3-80
HSK-A 63	3	10	18	36	120	17-SHF63A-3-120
HSK-A 63	3	10	18	36	160	17-SHF63A-3-160
HSK-A 63	4	10	18	36	80	17-SHF63A-4-80
HSK-A 63	4	10	18	36	120	17-SHF63A-4-120
HSK-A 63	4	10	18	36	160	17-SHF63A-4-160
HSK-A 63	5	16	22	36	80	17-SHF63A-5-80
HSK-A 63	5	16	22	36	120	17-SHF63A-5-120
HSK-A 63	5	16	22	36	160	17-SHF63A-5-160
HSK-A 63	6	21	27	36	80	17-SHF63A-6-80
HSK-A 63	6	21	27	36	120	17-SHF63A-6-120
HSK-A 63	6	21	27	36	160	17-SHF63A-6-160
HSK-A 63	8	21	27	36	80	17-SHF63A-8-80
HSK-A 63	8	21	27	36	120	17-SHF63A-8-120
HSK-A 63	8	21	27	36	160	17-SHF63A-8-160
HSK-A 63	10	24	32	42	85	17-SHF63A-10-85
HSK-A 63	10	24	32	42	120	17-SHF63A-10-120
HSK-A 63	10	24	32	42	160	17-SHF63A-10-160
HSK-A 63	12	24	32	47	90	17-SHF63A-12-90
HSK-A 63	12	24	32	47	120	17-SHF63A-12-120
HSK-A 63	12	24	32	47	160	17-SHF63A-12-160
HSK-A 63	14	27	34	47	90	17-SHF63A-14-90
HSK-A 63	14	27	34	47	120	17-SHF63A-14-120
HSK-A 63	14	27	34	47	160	17-SHF63A-14-160
HSK-A 63	16	27	34	50	95	17-SHF63A-16-95
HSK-A 63	16	27	34	50	120	17-SHF63A-16-120
HSK-A 63	16	27	34	50	160	17-SHF63A-16-160
HSK-A 63	18	33	42	50	95	17-SHF63A-18-95
HSK-A 63	18	33	42	50	120	17-SHF63A-18-120
HSK-A 63	18	33	42	50	160	17-SHF63A-18-160
HSK-A 63	20	33	42	52	100	17-SHF63A-20-100
HSK-A 63	20	33	42	52	120	17-SHF63A-20-120
HSK-A 63	20	33	42	52	160	17-SHF63A-20-160
HSK-A 63	25	44	53	58	120	17-SHF63A-25-120
HSK-A 63	25	44	53	58	160	17-SHF63A-25-160

Werkzeugaufnahmen mit HSK auch in Form C, E und F lieferbar
HSK tool holders are also available in form C, E and F



Kühlmittelröhrchen Coolant tubes

Für / For	D mm	Gewinde / Thread	Art.-Nr. / Order no.
HSK 32	6	M10x1	17-KMR32
HSK 40	8	M12x1	17-KMR40
HSK 50	10	M16x1	17-KMR50
HSK 63	12	M18x1	17-KMR63
HSK 80	14	M20x1,5	17-KMR80
HSK 100	16	M24x1,5	17-KMR100



Schlüssel für Kühlmittelröhrchen Wrench for coolant tubes

Für / For	Art.-Nr. / Order no.
HSK 63	17-SCH-KMR63
HSK 100	17-SCH-KMR100

Werkzeugaufnahmen mit HSK auch in Form B, C, E und F lieferbar
HSK tool holders are also available in form B, C, E and F



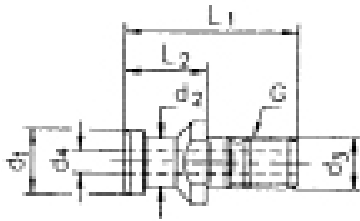

DIN 69872 A, mit Bohrung
DIN 69872 A, with bore

Größe / Size	G	D1 mm	D2 mm	D3 mm	D4 mm	L1 mm	L2 mm	Art.-Nr. / Order no.
SK 30	M 12	13	9	13	--	44	24	13-9884A-30-44
SK 40	M 16	19	14	17	7	54	26	13-9884A-40-54
SK 50	M 24	28	21	25	11,5	74	36	13-9884A-50-74

DIN 69872 B, ohne Bohrung
DIN 69872 B, without bore

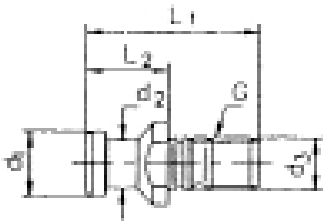

Größe / Size	G	D1 mm	D2 mm	D3 mm	L1 mm	L2 mm	Art.-Nr. / Order no.
SK 30	M 12	13	9	13	44	24	13-9884B-30-44
SK 40	M 16	19	14	17	54	26	13-9884B-40-54
SK 50	M 24	28	21	25	74	36	13-9884B-50-74

ISO 7388 II A, mit Bohrung
ISO 7388 II A, with bore

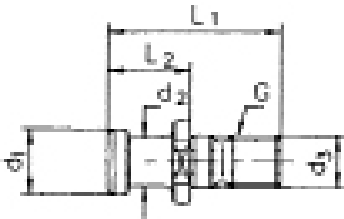

Größe / Size	G	D1 mm	D2 mm	D3 mm	D4 mm	L1 mm	L2 mm	Art.-Nr. / Order no.
SK 40	M 16	19	14	17	7	54	26	13-9885A-40-54
SK 50	M 24	28	21	25	11,5	74	36	13-9885A-50-74

ISO 7388 II B-OB, ohne Bohrung
ISO 7388 II B-OB, without bore

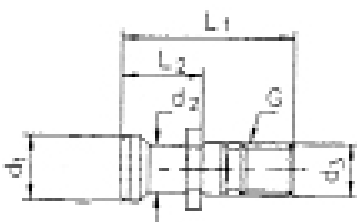

Größe / Size	G	D1 mm	D2 mm	D3 mm	L1 mm	L2 mm	Art.-Nr. / Order no.
SK 40	M 16	18,95	12,95	17	44,5	16,40	13-9885BOB-40-45
SK 50	M 24	29,10	19,80	25	65,5	25,56	13-9885BOB-50-66

ISO 7388 II B-MB, mit Bohrung
ISO 7388 II B-MB, with bore

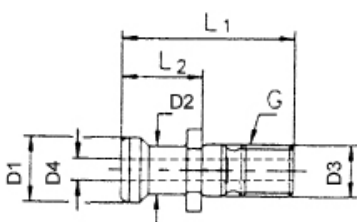

Größe / Size	G	D1 mm	D2 mm	D3 mm	D4 mm	L1 mm	L2 mm	Art.-Nr. / Order no.
SK 40	M 16	18,95	12,95	17	7	44,5	16,40	13-9885BMB-40-45
SK 50	M 24	29,10	19,80	25	11,5	65,5	25,56	13-9885BMB-50-66



Anzugsbolzen Pull studs

S 20x2, mit Sägewinde S 20x2, with saw thread

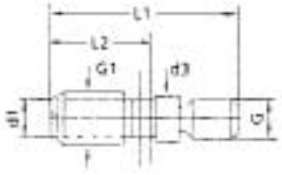

Größe / Size	G	G1	D1 mm	D3 mm	L1 mm	Art.-Nr. / Order no.
SK 40	M 16	S 20x2	16,6	17	58	● 13-9886B-40-58

MAS BT, 45° MAS BT, 45°

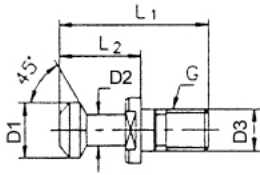

Größe / Size	G	D1 mm	D2 mm	D3 mm	L1 mm	L2 mm	Art.-Nr. / Order no.
SK 30	M 12	11	7	13	43	24	● 13-9882B-30-45
SK 40	M 16	15	10	17	60	35	● 13-9882B-40-45
SK 50	M 24	23	17	25	85	45	● 13-9882B-50-45

MAS BT, 60° MAS BT, 60°

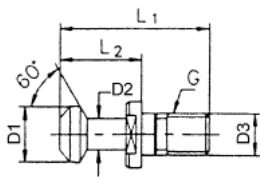

Größe / Size	G	D1 mm	D2 mm	D3 mm	L1 mm	L2 mm	Art.-Nr. / Order no.
SK 30	M 12	11	7	13	43	24	● 13-9882B-30-60
SK 40	M 16	15	10	17	60	35	● 13-9882B-40-60
SK 50	M 24	23	17	25	85	45	● 13-9882B-50-60

MAS BT, 90° MAS BT, 90°

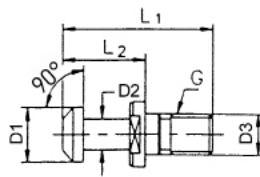

Größe / Size	G	D1 mm	D2 mm	D3 mm	L1 mm	L2 mm	Art.-Nr. / Order no.
SK 40	M 16	15	10	17	60	35	● 13-9882B-40-90
SK 50	M 24	23	17	25	85	45	● 13-9882B-50-90

MAS BT, 45°, mit Bohrung MAS BT, 45°, with bore

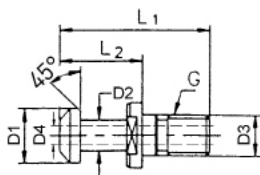

Größe / Size	G	D1 mm	D2 mm	D3 mm	D4 mm	L1 mm	L2 mm	Art.-Nr. / Order no.
SK 40	M 16	15	10	17	7	60	35	● 13-9882A-40-45
SK 50	M 24	23	17	25	11,5	85	45	● 13-9882A-50-45



OTT, ohne Bohrung
OTT, without internal bore

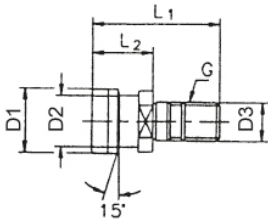

Größe / Size	G	D1 mm	D2 mm	D3 mm	L1 mm	L2 mm	Art.-Nr. / Order no.
SK 40	M 16	25,0	21,1	17	53	25	● 13-9883-40
SK 50	M 24	39,5	32,0	25	65	25	● 13-9883-50

OTT, mit Innengewinde
OTT, with internal thread

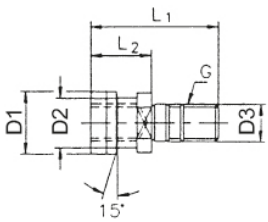

Größe / Size	G	D1 mm	D2 mm	D3 mm	L1 mm	L2 mm	Art.-Nr. / Order no.
SK 40	M 16	25,0	21,1	17	53	25	● 13-9883I-40
SK 50	M 24	39,5	32,0	25	65	25	● 13-9883I-50

Spezielle Anzugsbolzen für sämtliche
Maschinen auf Anfrage

*Special pull studs for all machines upon
request*

Steckschlüssel für Anzugsbolzen
Socket wrenches for pull studs



Sicherheits-Steckschlüssel SK und MAS BT
Security socket wrenches SK and MAS BT

Größe / Size	DIN	Art.-Nr. / Order no.
SK 40	DIN 69872	● 13-SCHA-SK40
SK 50	DIN 69872	● 13-SCHA-SK50
BT 40	MAS BT	● 13-SCHA-BT40
BT 50	MAS BT	● 13-SCHA-BT50



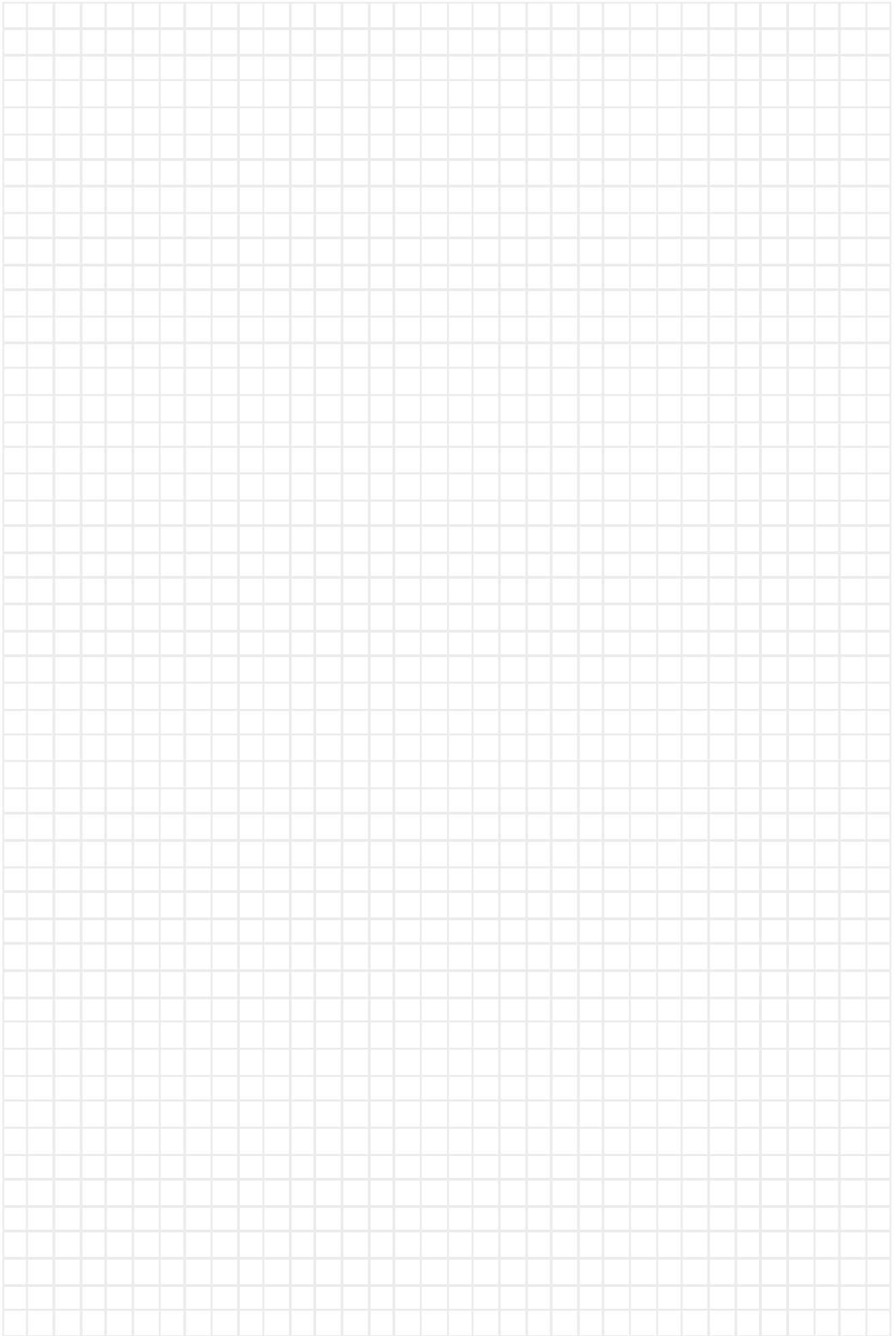

Ausdrehkopf-Sätze und Gewindeschneidfutter

Boring head sets and tapping chucks

12



■ Inhalt:

12.1 | Ausdrehkopf-Sätze

12.2 | Gewindeschneidfutter

- | Gewindeschneid-Schnellwechselfutter
- | Synchron-Gewindeschneidfutter
- | Gewindeschneidapparate mit autom. Rücklauf

■ Content:

12.1 | Boring head sets

12.2 | Tapping chucks

- | Quick-change tapping chucks
- | Synchro-tapping chucks
- | Reversal tapping heads

Ausdrehkopf-Sätze Boring head sets

12
12.1



Typ AKS 2G, Ausdrehbereich Ø 10 mm - 240 mm Type AKS 2G, boring capacity Ø 10 mm - 240 mm

- Skala 0,01 mm
- Lieferumfang: Ausdrehkopf, 4 Bohrstangen, 1 Ausdrehwerkzeug, je 1 Sechskantschlüssel 3, 4 und 6 mm
- scale 0,01 mm
- scope of delivery: boring head, 4 boring bars, 1 boring tool, hexagon wrench 3, 4 and 6 mm one each

Schaft / Shank	Bohrtiefe max. / Depth max. mm	kg	Art.-Nr. / Order no.
BT 40	120	6	09-AKS2G-BT40
DIN 69871 / SK 40	120	6,5	09-AKS2G-SK40
MK / MT 3	120	7,5	09-AKS2G-MK3
MK / MT 4	120	7	09-AKS2G-MK4



Typ AKS 1, Ausdrehbereich Ø 8 mm - 46 mm Type AKS 1, boring capacity Ø 8 mm - 46 mm

- Skala 0,005 mm
- Gesamt-Vorschub: 6 mm
- Lieferumfang: Ausdrehkopf, 8 Bohrstangen Ø 16 mm, Befestigungsschrauben, Bedienschlüssel
- scale 0,005 mm
- total stroke: 6 mm
- scope of delivery: boring head, 8 boring bars Ø 16 mm, screws, setting tool

Schaft / Shank	Bohrtiefe max. / Depth max. mm	kg	Art.-Nr. / Order no.
BT 40	90	7	09-AKS1-BT40
BT 50	90	8	09-AKS1-BT50
DIN 69871 / SK 40	90	7	09-AKS1-SK40
DIN 69871 / SK 50	90	8	09-AKS1-SK50

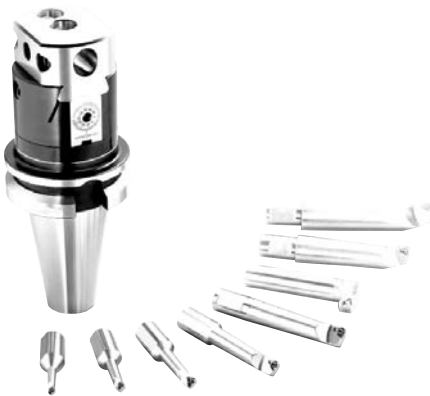

Typ AKS 2, Ausdrehbereich Ø 8 mm - 280 mm Type AKS 2, boring capacity Ø 8 mm - 280 mm

- Skala 0,005 mm
- Gesamt-Vorschub: 27 mm
- Lieferumfang: Ausdrehkopf, 8 Bohrstangen Ø 20 mm, Befestigungsschrauben, Bedienschlüssel
- scale 0,005 mm
- total stroke: 27 mm
- scope of delivery: boring head, 8 boring bars Ø 20 mm, screws, setting tool

Schaft / Shank	Bohrtiefe max. / Depth max. mm	kg	Art.-Nr. / Order no.
BT 40	115	8	09-AKS2-BT40
BT 50	115	10	09-AKS2-BT50
DIN 69871 / SK 40	115	8	09-AKS2-SK40
MK / MT 3	115	7	09-AKS2-MK3
MK / MT 4	115	7	09-AKS2-MK4
MK / MT 5	115	8	09-AKS2-MK5

Passende Wendschneidplatten Suitable inserts

AKS 2G Ausdrehbereich / Boring capacity	AKS 1 Ausdrehbereich / Boring capacity	AKS 2 Ausdrehbereich / Boring capacity	Wendschneidplatten / Inserts	Art.-Nr. / Order no.
Ø 10 - 240 mm	Ø 8 - 13 mm	Ø 8 - 13 mm	TBGT060102L	1M-TBGT060102L
-	Ø 12 - 15 mm	Ø 12 - 21 mm	TPGH090204L	1M-TPGH090204L
-	Ø 16 - 46 mm	Ø 20 - 280 mm	TPGH110304L	1M-TPGH110304L

Preis pro Stück. Abgabe nur in VE à 10 Stück
Price per piece. Only available in sets of 10 pieces

250

- Lagerstandard / in stock
- ▶ innerhalb weniger Tage / within a few days
- auf Anfrage / on request
- * auslaufende Größe / as stock lasts



Gewindeschneid-Schnellwechselfutter

Quick-change tapping chucks

Gewindeschneid-Schnellwechselfutter mit Morsekegel, mit Längenausgleich auf Zug und Druck

Quick-change tapping chucks with morse taper shank, with length compensation

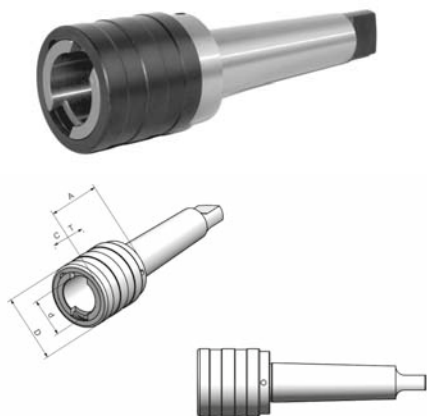

MK / MT	Größe / Size	Bereich / Range	A mm	D mm	D1 mm	Zug / Ext. mm	Druck / Compr. mm	Art.-Nr. / Order no.
MK / MT 2	1	M3 - M14	46	38	19	7,5	7,5	76-GSSF-MK2/1
MK / MT 3	1	M3 - M14	46	38	19	7,5	7,5	76-GSSF-MK3/1
MK / MT 3	2	M5 - M22	69	55	31	12,5	12,5	76-GSSF-MK3/2
MK / MT 4	2	M5 - M22	70	55	31	12,5	12,5	76-GSSF-MK4/2
MK / MT 4	3	M14 - M36	108	79	48	20	20	76-GSSF-MK4/3
MK / MT 5	3	M14 - M36	103	79	48	20	20	76-GSSF-MK5/3

Gewindeschneid-Schnellwechselfutter DIN 2080, mit Längenausgleich auf Zug und Druck

Quick-change tapping chucks DIN 2080, with length compensation

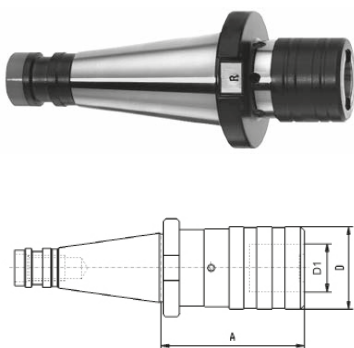

SK	Größe / Size	Bereich / Range	A mm	D mm	D1 mm	Art.-Nr. / Order no.
SK 40	1	M3 - M14	59	38	19	76-GSSF-ISO40/1
SK 40	2	M5 - M22	97	54	31	76-GSSF-ISO40/2
SK 40	3	M14 - M36	142	78	48	76-GSSF-ISO40/3
SK 50	1	M3 - M14	50	38	19	76-GSSF-ISO50/1
SK 50	2	M5 - M22	82	54	31	76-GSSF-ISO50/2
SK 50	3	M14 - M36	128	78	48	76-GSSF-ISO50/3

Gewindeschneid-Schnellwechselfutter DIN 69871, mit Längenausgleich auf Zug und Druck

Quick-change tapping chucks DIN 69871, with length compensation



SK	Größe / Size	Bereich / Range	A mm	D mm	D1 mm	Art.-Nr. / Order no.
SK 40	1	M3 - M14	59	38	19	76-GSSF-SK40/1
SK 40	2	M5 - M22	97	54	31	76-GSSF-SK40/2
SK 40	3	M14 - M36	156	78	48	76-GSSF-SK40/3
SK 50	1	M3 - M14	63	38	19	76-GSSF-SK50/1
SK 50	2	M5 - M22	97	54	31	76-GSSF-SK50/2
SK 50	3	M14 - M36	140	78	48	76-GSSF-SK50/3

Gewindeschneid-Schnellwechselfutter MAS BT, mit Längenausgleich auf Zug und Druck

Quick-change tapping chucks MAS BT, with length compensation

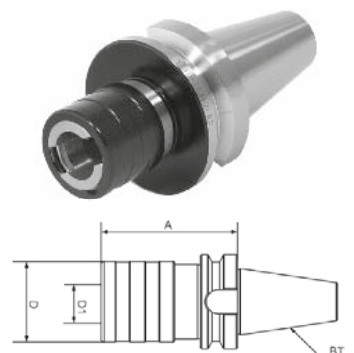

MAS BT	Größe / Size	Bereich / Range	A mm	D mm	D1 mm	Art.-Nr. / Order no.
BT 40	1	M3 - M14	65	38	19	76-GSSF-BT40/1
BT 40	2	M5 - M22	93	54	31	76-GSSF-BT40/2
BT 40	3	M14 - M36	166	78	48	76-GSSF-BT40/3
BT 50	1	M3 - M14	100	38	19	76-GSSF-BT50/1
BT 50	2	M5 - M22	100	54	31	76-GSSF-BT50/2
BT 50	3	M14 - M36	142	78	48	76-GSSF-BT50/3

Passende Einsätze siehe Seite 253
Suitable inserts see page 253

Gewindeschneid-Schnellwechselfutter Quick-change tapping chucks

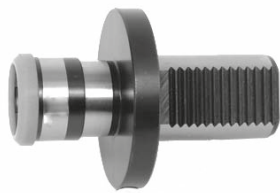

Gewindeschneid-Schnellwechselfutter VDI (DIN 69880), mit Längenausgleich auf Zug und Druck Quick-change tapping chucks VDI (DIN 69880), with length compensation

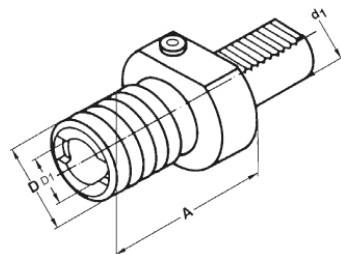

VDI	Größe / Size	Bereich / Range	A mm	D mm	D1 mm	Art.-Nr. / Order no.
VDI 20	1	M3 - M14	55	38	19	76-GSSF-VDI20/1
VDI 25	1	M3 - M14	55	38	19	76-GSSF-VDI25/1
VDI 30	1	M3 - M14	55	38	19	76-GSSF-VDI30/1
VDI 30	2	M5 - M22	77	54	31	76-GSSF-VDI30/2
VDI 40	1	M3 - M14	55	38	19	76-GSSF-VDI40/1
VDI 40	2	M5 - M22	77	54	31	76-GSSF-VDI40/2
VDI 40	3	M14 - M36	108	78	48	76-GSSF-VDI40/3
VDI 50	2	M5 - M22	77	54	31	76-GSSF-VDI50/2
VDI 50	3	M14 - M36	108	78	48	76-GSSF-VDI50/3

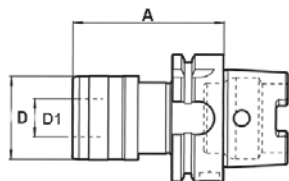

Gewindeschneid-Schnellwechselfutter DIN 69893 HSK - A, mit Längenausgleich auf Zug und Druck Quick-change tapping chucks DIN 69893 HSK - A, with length compensation

HSK	Größe / Size	Bereich / Range	A mm	D mm	D1 mm	Art.-Nr. / Order no.
HSK-50A	1	M3 - M14	72	41	19	76-GSSF-HSK50A/1
HSK-50A	2	M5 - M22	110	60	31	76-GSSF-HSK50A/2
HSK-63A	1	M3 - M14	72	41	19	76-GSSF-HSK63A/1
HSK-63A	2	M5 - M22	110	60	31	76-GSSF-HSK63A/2

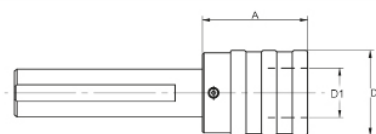

Gewindeschneid-Schnellwechselfutter zylindrisch, mit Längenausgleich auf Zug und Druck Quick-change tapping chucks cylindrical, with length compensation

Schaft-Ø / Shank-Ø	Größe / Size	Bereich / Range	A mm	D mm	D1 mm	Art.-Nr. / Order no.
20	1	M3 - M14	40	36	19	76-GSSF-ZYL20/1
25	1	M3 - M14	40	36	19	76-GSSF-ZYL25/1
25	2	M5 - M22	64	53	31	76-GSSF-ZYL25/2
32	2	M5 - M22	64	53	31	76-GSSF-ZYL32/2
32	3	M14 - M36	97	78	48	76-GSSF-ZYL32/3

Passende Einsätze siehe Seite 253
Suitable inserts see page 253

Gewindeschneid-Schnellwechseleinsätze Quick-change tapping inserts



Mit Rutschkupplung With safety clutch

Größe / Size	Bereich / Thread	Art.-Nr. / Order no.
0	M1 - M10	76-GEM0-M...
1	M3 - M14	76-GEM1-M...
2	M5 - M22	76-GEM2-M...
3	M14 - M36	76-GEM3-M...
4	M24 - M48	76-GEM4-M...



Ohne Rutschkupplung Without safety clutch

Größe / Size	Bereich / Thread	Art.-Nr. / Order no.
0	M1 - M10	76-GEO0-M...
1	M2 - M2,5	76-GEO1-M...
1	M3 - M14	76-GEO1-M...
2	M5 - M22	76-GEO2-M...
3	M14 - M36	76-GEO3-M...

Reduzierungen für Gewindeschneid-Schnellwechseleinsätze Reductions sleeves for quick-change tapping inserts

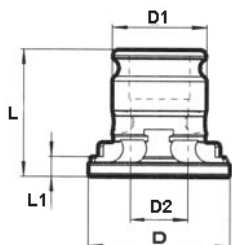

Von Größe auf Größe / From size to size	D1 mm	D2 mm	D mm	L mm	L1 mm	Art.-Nr. / Order no.
1/0	19	13	30	21,5	6	76-SRE-1/0
2/1	31	19	46	35	8,5	76-SRE-2/1
3/1	48	19	68	55,5	7	76-SRE-3/1
3/2	48	31	68	55,5	7	76-SRE-3/2

Synchron-Gewindeschneidfutter

Synchro-tapping chucks

- zum Gewindeschneiden auf Bearbeitungszentren mit Synchronsteuerung
- Micro-Längenausgleich auf Zug (1 mm) und Druck (0,2 mm)
- passende Schnellwechseleinsätze siehe Seite 255
- for synchronized tapping
- micro compensation: in extension (1 mm), in compression (0,2 mm)
- suitable inserts see page 255

Grundkörper DIN 69893 HSK - A

Base body DIN 69893 HSK - A

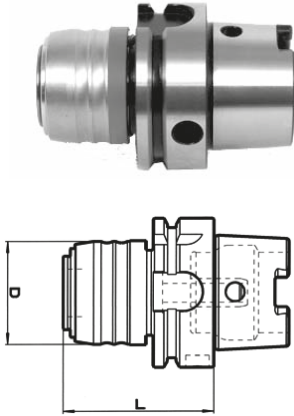

Größe / Size	D1 mm	D mm	L mm	Bereich / Tap capacity	Art.-Nr. / Order no.
HSK-40A	20	43	69	M3-M12	76-SYNC-HSKA40/1
HSK-50A	20	43	70	M3-M12	76-SYNC-HSKA50/1
HSK-63A	20	43	64	M3-M12	76-SYNC-HSKA63/1
HSK-100A	20	43	70	M3-M12	76-SYNC-HSKA100/1
HSK-40A	32	60	90	M6-M20	76-SYNC-HSKA40/2
HSK-50A	32	60	97	M6-M20	76-SYNC-HSKA50/2
HSK-63A	32	60	97	M6-M20	76-SYNC-HSKA63/2
HSK-100A	32	60	91	M6-M20	76-SYNC-HSKA100/2
HSK-100A	50	87	115	M14-M33*	76-SYNC-HSKA100/3

* Längenausgleich auf Zug (2 mm) und Druck (0,4 mm)
 * compensation in extension (2 mm) and in compression (0,4 mm)

Grundkörper DIN 69871

Base body DIN 69871

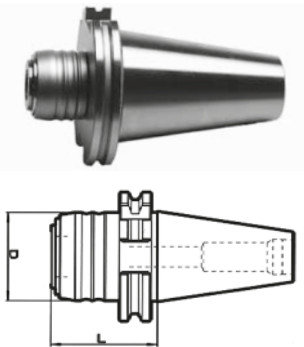

Größe / Size	D1 mm	D mm	L mm	Bereich / Tap capacity	Art.-Nr. / Order no.
SK 40	20	43	53	M3-M12	76-SYNC-SK40/1
SK 50	20	43	53	M3-M12	76-SYNC-SK50/1
SK 40	32	60	90	M6-M20	76-SYNC-SK40/2
SK 50	32	60	74	M6-M20	76-SYNC-SK50/2

Grundkörper MAS BT

Base body MAS BT

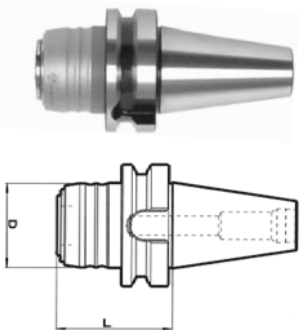

Größe / Size	D1 mm	D mm	L mm	Bereich / Tap capacity	Art.-Nr. / Order no.
BT 40	20	43	61	M3-M12	76-SYNC-BT40/1
BT 50	20	43	72	M3-M12	76-SYNC-BT50/1
BT 40	32	60	82	M6-M20	76-SYNC-BT40/2
BT 50	32	60	93	M6-M20	76-SYNC-BT50/2

Grundkörper DIN 69880

Base body DIN 69880

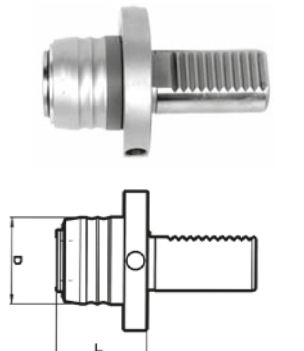

Größe / Size	D1 mm	D mm	L mm	Bereich / Tap capacity	Art.-Nr. / Order no.
VDI 30	20	43	46	M3-M12	76-SYNC-VDI30/1
VDI 40	20	43	46	M3-M12	76-SYNC-VDI40/1
VDI 30	32	60	67	M6-M20	76-SYNC-VDI30/2
VDI 40	32	60	67	M6-M20	76-SYNC-VDI40/2

Weitere Grundkörper auf Anfrage
 Further base bodies upon request



Schnellwechseleinsätze für Synchron-Gewindeschneidfutter

Tapping inserts for synchro-tapping chucks

Schnellwechseleinsatz

Tapping inserts

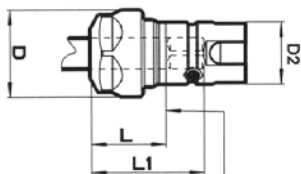

- Verdrehsicherung durch Schrauben - locking by screws
- keine Gewindebohrzangen notwendig - no need to use tapping collets

D2 mm	D mm	L mm	L1 mm	Bereich / Tap capacity	Für Spannzangen / For collets	Art.-Nr. / Order no.
20*	28	24	37	M3-M12	ER 16 (1-10)	▶ 76-SYNC-SE1
32	42	28	52	M6-M20	ER 25 (2-16)	▶ 76-SYNC-SE2
50	63	32	75	M14-M33	ER 40 (3-30)	▶ 76-SYNC-SE3

* Lieferung mit Sechskantmutter
* Supplied with hexagonal nut

Verlängerter Schnellwechseleinsatz

Extended tapping inserts

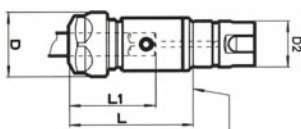

- schlanke Version, für beengte Platzverhältnisse geeignet - extra slim for limited space conditions

D2 mm	D mm	L mm	L1 mm	Bereich / Tap capacity	Für Spannzangen / For collets	Art.-Nr. / Order no.
20*	28	55	38	M3-M12	ER 16 (1-10)	▶ 76-SYNC-VSE1
32	42	86	63	M6-M20	ER 25 (2-16)	▶ 76-SYNC-VSE2
50	63	95	73	M14-M33	ER 40 (3-30)	▶ 76-SYNC-VSE3

* Lieferung mit Sechskantmutter
* Supplied with hexagonal nut

Weitere Verlängerungen und Endstücke auf Anfrage
Further extensions and end pieces upon request

Montagebeispiel

Example

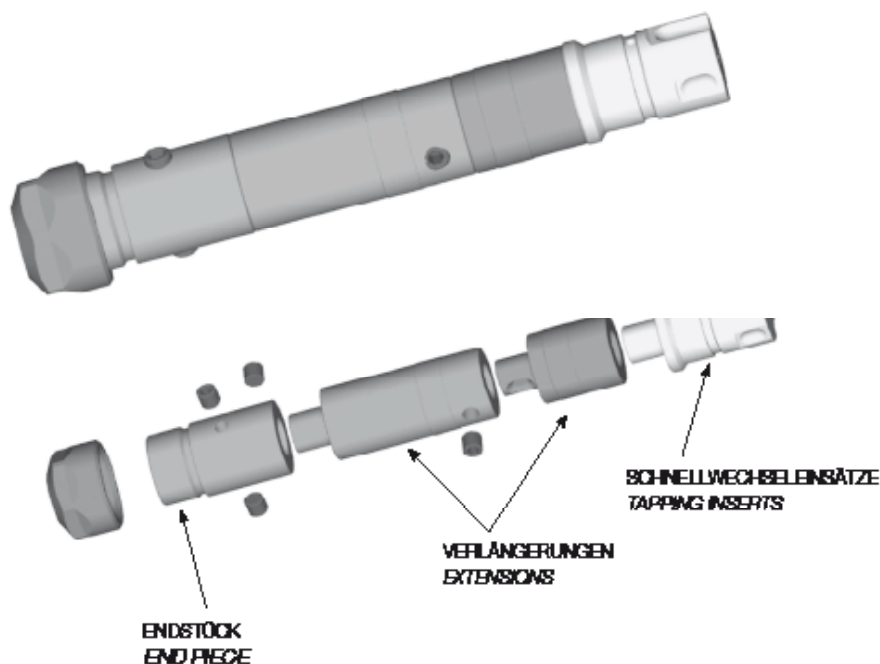

Gewindeschneidapparate mit automatischem Rücklauf

Reversal tapping chucks



Gewindeschneidapparate BASIC

Reversal tapping chucks BASIC

- mit automatischem Vorschub
- eingebauter Schnellrücklauf 1,75 : 1
- einstellbare Sicherheits-Rutschkupplung
- Längenausgleich auf Druck und Zug
- automatic feed
- rapid reversal 1,75 : 1
- adjustable safety clutch
- length compensation

Lieferumfang: 2 Mehrbereichs-Spannzangen und alle notwendigen Schlüssel

Scope of delivery: incl. 2 multi-range collets and all required wrenches

Größe / Size	Aufnahme / Mounting	Bereich / Capacity	Ø D mm	Max. Drehmoment / Max. torque Nm	Max. Drehzahl / Max. speed RPM	Art.-Nr. / Order no.
7	B16	M2 - M7	55	14	1500	● BAS-GSA-M7
12	B16	M5 - M12	75	65	1000	● BAS-GSA-M12
20	B22	M8 - M20	91	125	600	● BAS-GSA-M20

Passende Kegeldorne siehe Seiten 104 - 105

Suitable taper arbors see pages 104 - 105

Mehrbereich-Spannzangen

Multi-range collets

- für Gewindeschneidapparate
- for reversal tapping chucks

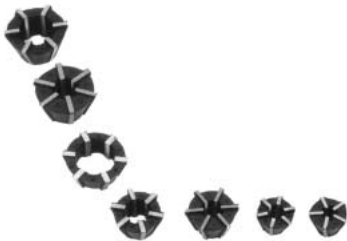

Größe / Size	Bereich / Capacity	Spannbereich / Clamping capacity	Art.-Nr. / Order no.
7	M2 - M7	Ø 2,5-4,2	● 06-RF7-4,5
7	M4 - M7	Ø 4,2-6,5	● 06-RF7-6,5
12	M5 - M8	Ø 3,5-7	● 06-RF12-7,0
12	M8 - M12	Ø 7,0-10,0	● 06-RF12-10,0
20	M8 - M14	Ø 6,0-9,0	● 06-RF20-9,0
20	M14 - M20	Ø 9,0-14,0	● 06-RF20-14,0

Zubehör

Accessories



■ Inhalt:

13.1 | Zubehör für Drehfutter und Planscheiben

- | Sicherheits- Dreh- und Schleifmitnehmer
- | Hohlspindelanschlage

13.2 | Zubehör für Schraubstöcke

- | Passsteine
- | Universal-Werkstückanschlag
- | Universal-Werkstückanschlag mit Magnet

13.3 | Zubehör für Steilkegelaufnahmen

- | Kegelwischer
- | Fräsdornringe
- | Schlüssel
- | Fräseranzugsschrauben
- | Austreiblappen
- | Überwurfmuttern
- | Mitnehmerringe
- | Passfedern
- | Spannschrauben für Weldon Futter
- | Austreiber
- | Schraubquerkeile
- | Kühlmittelröhrchen
- | Werkzeug-Regale
- | Werkzeugwagen
- | Montagehilfen

■ Content:

13.1 | Accessories for lathe and independent chucks

- | Safety driving rings
- | Hollow spindle stops

13.2 | Accessories for vices

- | Tee nuts
- | Stop dog
- | Universal work piece stop with magnet

13.3 | Accessories for SK-tooling

- | Taper cleaners
- | Spacing collars
- | Spanners
- | Cross retaining screws
- | Tangs
- | Clamping nuts
- | Clutch drive rings
- | Feather keys
- | Clamping screws for Weldon chucks
- | Ejectors
- | Driving tenons
- | Coolant tubes
- | Tool racks
- | Tooling trolleys
- | Assembly supports

Sicherheits- Dreh- und Schleifmitnehmer Safety drive rings



- Nachfolger des nicht mehr zulässigen Drehherzes
- Keine Unfallgefahr, da keine hervorstehenden Teile
- Eingestellter Spanndurchmesser wird beibehalten
- Zweiteilig - kann auch bei eingespanntem Werkstück angebracht werden
- No risk of injuries since free from protruding elements
- Adjusted clamping diameter is maintained
- Split design to allow mounting while work-piece is clamped

Größe / Size	Spannbereich / Clamping range mm	Art.-Nr. / Order no.
1	10-40	● 00-SM-1
2	40-70	● 00-SM-2
3	70-100	● 00-SM-3
4	100-150	○ 00-SM-4
5	150-200	○ 00-SM-5
6	200-250	○ 00-SM-6

Hohlspindelanschlüsse Hollow spindle stops



Optimales Hilfswerkzeug passend für nahezu jede Drehbank. Lohnend schon ab Kleinstserien. Teure Rüstzeiten können auf ein Minimum reduziert werden. Problemlos und schnell an jeder Stelle der Hohlspindel zu fixieren. Durch Anziehen mit dem mitgelieferten Schlüssel werden die integrierten Spannbacken an die Innenwand gepresst und gewährleisten so einen sicheren Sitz.

Useful auxiliary tool suitable for almost every lathe. Worthwhile even for small series production. Expensive set-up time can be reduced to a minimum. Quick and easy fixing at any position of the hollow spindle. By tightening with the enclosed key the integrated jaws are pressed against the spindle so that a secure seat is guaranteed.



Spindel-Ø / Spindle-Ø	Art.-Nr. / Order no.
20-27	● 83-322327
25-33	● 83-332731
32-41	● 83-343139
40-50	● 83-353947
48-60	● 83-364757
58-76	● 83-386578
75-96	● 83-397894
94-110	● 83-31094110

Ersatz O-Ringe auf Anfrage / Spare O-Rings upon request



Passteine, Paar Tee nuts, set of 2 pieces

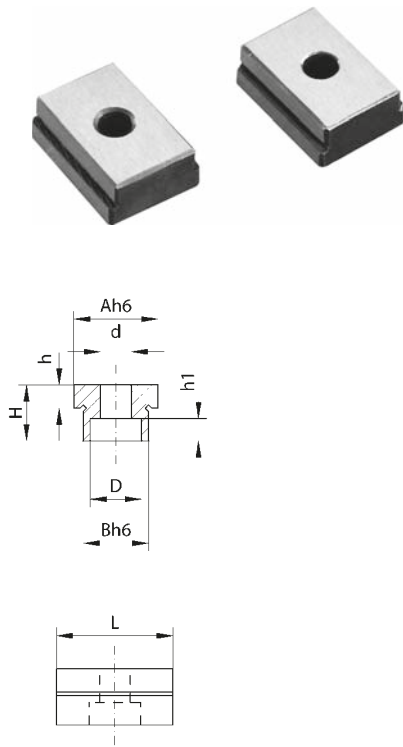

A mm	B mm	L mm	H mm	h mm	h1 mm	D mm	d mm	Art.-Nr. / Order no.
12	12	25	10	4,8	5,7	10	6	14-12-12
14	14	25	10	0	5,7	10	6	14-14-14
	18			4,8				14-14-18
	20			4,8				14-14-20
	22			4,8				14-14-22
16	12	25	10	4,8	5,7	10	6	14-16-12
	14			4,8				14-16-14
	16			0				14-16-16
	18			4,8				14-16-18
	20			4,8				14-16-20
	22			4,8				14-16-22
	24			4,8				14-16-24
	28			4,8				14-16-28
36	4,8	14-16-36						
18	12	25	10	4,8	5,7	10	6	14-18-12
	14			4,8				14-18-14
	16			4,8				14-18-16
	18			0				14-18-18
	20			4,8				14-18-20
	22			4,8				14-18-22
20	12	25	10	4,8	5,7	10	6	14-20-12
	14			4,8				14-20-14
	16			4,8				14-20-16
	18			4,8				14-20-18
	20			0				14-20-20
	22			4,8				14-20-22
22	14	25	10	4,8	5,7	10	6	14-22-14
	16			4,8				14-22-16
	18			4,8				14-22-18
	20			4,8				14-22-20
	22			0				14-22-22

Preis pro Paar / Price per set

Universal-Werkstückanschlag Universal stop-dog



- Universal-Werkstückanschlag aus zweifarbig eloxiertem Aluminium für Bohr- und Fräsmaschinen
- durch die zwei Gelenkpfannen und den 360° drehbaren Kopf ist jede Einstell-Lage möglich
- inkl. Nutenstein (für 16, 18 und 20 mm T-Nuten), Anschlagstange und Inbusschlüssel
- universal two-coloured work piece stop made from anodized aluminium for boring and milling machines
- two cranks and a knob (360° pivotable) allow any setting angle
- incl. t-nut (for 16, 18 and 20 mm), stop rod and hexagon wrench

Höhe Anschlagst. / Height of stop rod mm	Gesamthöhe / Total height mm	Anschlagst.-Ø / Stop rod dia. mm	Art.-Nr. / Order no.
155	215	8	09-AMS-160BH

Universal-Werkstückanschlag mit Magnet Universal work piece stop with magnet



- passend für alle Schraubstöcke
- keine Gewindebohrungen nötig
- suitable for all types of vices
- no threads required

Gesamthöhe / Total height mm	Länge der Anschlagstange / Length of stop rod mm	Anschlagst.-Ø / Stop rod-Ø mm	Art.-Nr. / Order no.
100	125	6	09-WAM

Lagerstandard / in stock
innerhalb weniger Tage / within a few days
auf Anfrage / on request
auslaufende Größe / as stock lasts

Kegelwischer Taper cleaners



SK

- Material: Holz

- material: wood

Größe / Size	Art.-Nr. / Order no.
SK 30	09-76200030
SK 40	09-76200040
SK 45	09-76200045
SK 50	09-76200050
SK 60	09-76200060



MK / MT

- Material: Holz

- material: wood

Größe / Size	Art.-Nr. / Order no.
MK 1	09-76200001
MK 2	09-76200002
MK 3	09-76200003
MK 4	09-76200004
MK 5	09-76200005
MK 6	09-76200006



HSK

- Material: Kunststoff
- passend für Form A / C / E

- material: plastic
- suitable for form A / C / E

Größe / Size	Art.-Nr. / Order no.
HSK 32	09-76205032
HSK 40	09-76205040
HSK 50	09-76205050
HSK 63	09-76205063
HSK 80	09-76205080
HSK 100	09-762050100



ER

- Material: Holz

- material: wood

Größe / Size	Art.-Nr. / Order no.
ER 16	09-76202016
ER 20	09-76202020
ER 25	09-76202025
ER 32	09-76202032
ER 40	09-76202040



OZ

- Material: Holz

- material: wood

Größe / Size	Art.-Nr. / Order no.
OZ 16 (415E / 410E)	09-76203016
OZ 25 (462E / 444E)	09-76203025
OZ 32 (467E / 450E)	09-76203032

Fräsdornringe DIN 2084 A Spacing collars DIN 2084 A



Weitere Größen auf Anfrage
Further sizes available upon request

Form A

Aus federhartem Spezialstahl gestanz
und entgratet.

From punched spring steel, deburred edges.

Bohr-Ø / Bore-Ø	16	22	27	32	40	50	60
Außen-Ø / External-Ø	25	33	39	45	54	67	83
Stärke / Thickness mm	0,03						
0,04							
0,05							
0,10							
0,20							
0,30							
0,40							
0,50							
0,60							
1,00							

Art.-Nr.
Order no.

Beispiel / Ordering example: 27 x 0,03 = 09-2084A27003

09-2084AØ

Der Preis versteht sich pro Stück.
Price is per piece.

Fräsdornringe DIN 2084 B Spacing collars DIN 2084 B



Weitere Größen und Endringe
auf Anfrage
Further sizes and end rings
available upon request

Form B

Aus Stahl gedreht, gehärtet, planparallel
geschliffen und geläppt.

Turned from steel, hardened, ground and lapped.

Bohr-Ø / Bore-Ø	13	16	22	27	32	40	50	60
Außen-Ø / External-Ø	22	27	34	41	47	55	69	83
Stärke / Thickness mm	1							
2								
3								
4								
5								
6								
10								
20								
30								
60								
100								

Art.-Nr.
Order no.

Beispiel / Ordering example: 16 x 1 = 09-2084B161

09-2084BØ

Der Preis versteht sich pro Stück.
Price is per piece.

Lagerstandard / in stock
innerhalb weniger Tage / within a few days
auf Anfrage / on request
auslaufende Größe / as stock lasts



Fräsdornringe DIN 2084 B

Spacing collars DIN 2084 B

Fräsdornringe-Sortiment

Spacing collar sets



- Lieferung erfolgt in Kunststofftasche - delivered in plastic case

Sortiment / Set	Bohrung / Bore mm	Inhalt / Contents	Art.-Nr. / Order no.
1	16	60	● 09-2084A16S1
1	22	60	● 09-2084A22S1
1	27	60	● 09-2084A27S1
1	32	60	● 09-2084A32S1
1	40	60	● 09-2084A40S1
2	16	35	● 09-2084A16S2
2	22	35	● 09-2084A22S2
2	27	35	● 09-2084A27S2
2	32	35	● 09-2084A32S2
2	40	35	● 09-2084A40S2

Sortiment / Set	0,03	0,04	0,05	0,1	0,2	0,3	0,5	0,6	1,0	1,5
1	10	10	10	10	5	5	4	3	2	1
2	5	5	5	6	3	3	3	2	2	1

13
133

Zubehör für Steilkegelaufnahmen / Accessories for SK tooling



Schlüssel Spanners



Sicherheitsschlüssel ER Mini Safety-spanners ER Mini

Größe / Size	Art.-Nr. / Order no.
ER 8 M	09-SCH-ER8M
ER 11 M	09-SCH-ER11M
ER 16 M	09-SCH-ER16M
ER 20 M	09-SCH-ER20M
ER 25 M	09-SCH-ER25M



Sicherheitsschlüssel ER Safety-spanners ER

Größe / Size	Art.-Nr. / Order no.
ER 16	09-SCH-ER16
ER 20	09-SCH-ER20
ER 25	09-SCH-ER25
ER 32	09-SCH-ER32
ER 40	09-SCH-ER40
ER 50	09-SCH-ER50



Hakenschlüssel OZ Hook wrenches OZ

Für SZ / For collet	Ø mm	Art.-Nr. / Order no.
415 E (OZ 16)	43	09-SCH-OZ16
462 E (OZ 25)	60	09-SCH-OZ25
467 E (OZ 32)	72	09-SCH-OZ32
468 E (OZ 40)	82	09-SCH-OZ40

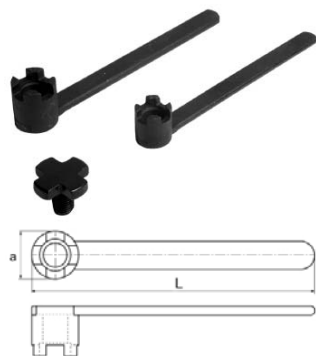

Schlüssel für Fräseranzugsschrauben DIN 6368 Spanners for cross screws DIN 6368

Ø Fräsdorn / Ø Arbor	L mm	Art.-Nr. / Order no.
13	160	09-SCH-KD13
16	180	09-SCH-KD16
22	200	09-SCH-KD22
27	225	09-SCH-KD27
32	250	09-SCH-KD32
40	280	09-SCH-KD40
50	315	09-SCH-KD50

Fräseranzugsschrauben Cross retaining screws

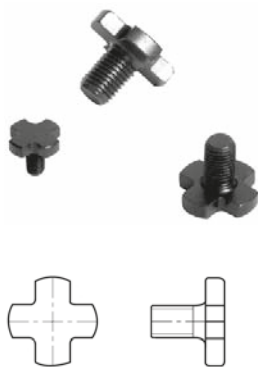

Für Fräsdorne DIN 6367 For shell end mill holders DIN 6367

Ø Fräsdorn / Ø Arbor	Gewinde / Thread	Art.-Nr. / Order no.
13	M6	● 09-VTC-M6
16	M8	● 09-VTC-M8
22	M10	● 09-VTC-M10
27	M12	● 09-VTC-M12
32	M16	● 09-VTC-M16
40	M20	● 09-VTC-M20

Für Fräsdorne DIN 6367 mit innerer Kühlmittelzufuhr For shell end mill holders DIN 6367 with IC

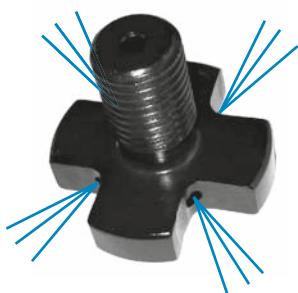

Ø Fräsdorn / Ø Arbor	Gewinde / Thread	Art.-Nr. / Order no.
16	M8	● 09-VTCIK-M8
22	M10	● 09-VTCIK-M10
27	M12	● 09-VTCIK-M12
32	M16	● 09-VTCIK-M16
40	M20	● 09-VTCIK-M20

Austreibblappen Tangs



Einschraubbare Austreibblappen für Morsekegel Removable tangs for morse taper shanks

Größe / Size	Gewinde / Thread	Art.-Nr. / Order no.
MK 1	M6	● 09-ATL-MK1
MK 2	M10	● 09-ATL-MK2
MK 3	M12	● 09-ATL-MK3
MK 4	M16	● 09-ATL-MK4
MK 5	M20	● 09-ATL-MK5

Überwurfmuttern OZ Standard clamping nuts OZ

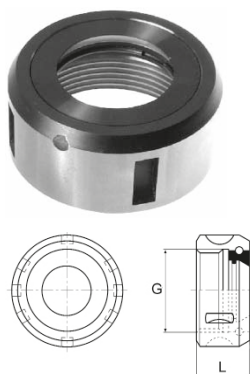

Kugellagert With roller-bearing

Für SZ / For collet	G	L mm	Art.-Nr. / Order no.
OZ 16 (415E)	M33 x 1,5	24	● 09-GOC-16
OZ 20 (4541E)	M42 x 2	28	● 09-GOC-20
OZ 25 (462E)	M48 x 2	30	● 09-GOC-25
OZ 32 (467E)	M60 x 2,5	33,5	● 09-GOC-32
OZ 40 (468E)	M68 x 2,5	37	● 09-GOC-40

Überwurfmutter ER Clamping nuts ER

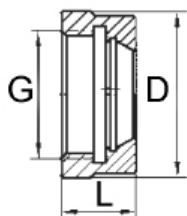
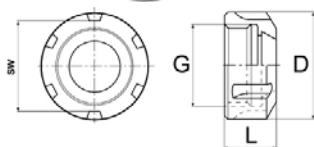
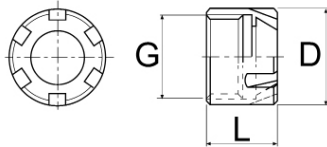

Mitnehmerringe Clutch drive rings

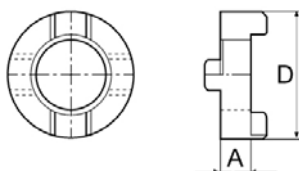

Mini Mini

Für SZ / For collet	G mm	D mm	L mm	Art.-Nr. / Order no.
ER 8	M10 x 0,75	12	10,8	● 09-G-8M
ER 11	M13 x 0,75	16	12	● 09-G-11M
ER 16	M19 x 1	22	18	● 09-G-16M
ER 20	M24 x 1	28	19	● 09-G-20M
ER 25	M30 x 1	35	20	● 09-G-25M

Standard Standard

Für SZ / For collet	G mm	D mm	L mm	SW	Art.-Nr. / Order no.
ER 16	M22 x 1,5	32	17	27	● 09-UM-ER16
ER 20	M25 x 1,5	35	18,5	30	● 09-UM-ER20
ER 25	M32 x 1,5	42	20	37	● 09-UM-ER25
ER 32	M40 x 1,5	50	22,5	45	● 09-UM-ER32
ER 40	M50 x 1,5	63	25,5	58	● 09-UM-ER40
ER 50	M64 x 2,0	78	35,5	72	● 09-UM-ER50

Sechskant Hexagonal

Für SZ / For collet	G mm	D mm	L mm	SW	Art.-Nr. / Order no.
ER 16	M22 x 1,5	28	17,5	25	● 09-UM-ER16H
ER 20	M25 x 1,5	34	19	30	● 09-UM-ER20H

Für Fräsdorne DIN 6366 For combination end mill holders DIN 6366

Ø Fräsdorn / Ø Arbor	D mm	A mm	Art.-Nr. / Order no.
D13	28	10	● 09-ATR-D13
D16	32	10	● 09-ATR-D16
D22	40	12	● 09-ATR-D22
D27	48	12	● 09-ATR-D27
D32	58	14	● 09-ATR-D32
D40	70	14	● 09-ATR-D40
D50	90	16	* 09-ATR-D50



Passfedern Feather keys



Für Kombi-Fräseraufsteckdorne For combination end mill adaptors

- mit Abdrückschraube

- with push-off screw

H mm	B mm	L mm	Schraube / Screw	Art.-Nr. / Order no.
4	4	20	M2 x 4	● 09-PAF-M2/4
6	6	25	M3 x 5	● 09-PAF-M3/6
7	7	25	M3 x 6	● 09-PAF-M3/7
8	7	28	M3 x 6	● 09-PAF-M3/8
10	8	32	M3 x 6	● 09-PAF-M3/10

Spannschrauben Clamping screw



Für Weldon Spannfutter, DIN 1835B For Weldon chucks, DIN 1835B

Für Ø / For Ø mm	Gewinde / Thread mm	L mm	Art.-Nr. / Order no.
6	M6	10	● 09-WSS-M6/10
8	M8	10	● 09-WSS-M8/10
10	M10	12	● 09-WSS-M10/12
12-14	M12	16	● 09-WSS-M12/16
16-18	M14	16	● 09-WSS-M14/16
20	M16	16	● 09-WSS-M16/16
25	M18 x 2	20	● 09-WSS-M18/20
32-40	M20 x 2	20	● 09-WSS-M20/20

Austreiber Ejectors



Größe / Size	L mm	Art.-Nr. / Order no.
MK 0	90	01-2000
MK 1+2	140	01-2002
MK 3	190	01-2003
MK 4	225	01-2004
MK 5+6	265	01-2005

Halbautomatische Austreiber Half automatic ejectors



- Einhandbedienung
- Vermeidung von Spindelbeschädigungen beim Lösen der Werkzeuge
- *single-hand operation*
- *no risk of damage to the spindle when removing the tools*

Größe / Size	Länge / Length mm	Art.-Nr. / Order no.
MK 1+2+3	317	01-8003
MK 4+5+6	380	01-8006

Schraubquerkeile Driving tenons

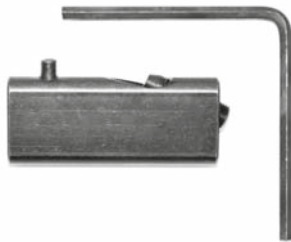

- zum Spannen von Kegelschäften mit Mitnehmerlappen und Querkeilschlitz
- große Sicherheit durch festen Sitz
- schnelles Spannen und Lösen mit einer Schraube
- Schonung der Spindellager
- *secure clamping of taper shanks with tenons and driving slots*
- *higher safety thanks to tight fit*
- *fast clamping and removing with one screw*
- *less impact on spindle bearings*

MK / MT	Für Spindel-Ø / For spindle-Ø mm	Art.-Nr. / Order no.
3	36	09-SQ-3-36
4	48	09-SQ-4-48
4	63	09-SQ-4-63
5	63	09-SQ-5-63
5	80	09-SQ-5-80
6	100	09-SQ-6-100

Kühlmittelröhrchen Coolant tubes



Für / For	D mm	G mm	Art.-Nr. / Order no.
HSK 32	6	M10x1	17-KMR32
HSK 40	8	M12x1	17-KMR40
HSK 50	10	M16x1	17-KMR50
HSK 63	12	M18x1	17-KMR63
HSK 80	14	M20x1,5	17-KMR80
HSK 100	16	M24x1,5	17-KMR100

Werkzeug-Regale Tool racks



Werkzeugregale 3-stufig, Typ WR3K2 Tool racks 3-staged, type WR3K2

- inkl. Einsätze
- passend für alle Einsätze
- incl. inserts
- suitable for all types of inserts

Kegelgröße / Shank size	Plätze / Tool seats	Art.-Nr. / Order no.
SK 30 / BT 30	24	● WZ-WR3K2-SK30
SK 40 / BT 40	21	● WZ-WR3K2-SK40
SK 50 / BT 50	15	● WZ-WR3K2-SK50
HSK 63	18	● WZ-WR3K2-HSK63

Werkzeugregale 1-stufig, Typ WRS2 Tool racks 1-staged, type WRS2



- inkl. Einsätze
- modulares System
- passend für alle Einsätze
- incl. inserts
- modular system
- suitable for all types of inserts

Kegelgröße / Shank size	Plätze / Tool seats	Art.-Nr. / Order no.
SK 30 / BT 30	8	● WZ-WRS2-SK30
SK 40 / BT 40	7	● WZ-WRS2-SK40
SK 50 / BT 50	6	● WZ-WRS2-SK50
HSK 63	6	● WZ-WRS2-HSK63

Werkzeugregaleinsätze Tool rack inserts



Kegelgröße / Shank size	Art.-Nr. / Order no.
SK 30 / BT 30	● WZ-RE2-SK30
SK 40 / BT 40	● WZ-RE2-SK40
SK 50 / BT 50	● WZ-RE2-SK50
HSK 63	● WZ-RE2-HSK63

Werkzeugwagen Tooling trolleys



Werkzeugwagen Tooling trolley

- Maße: 1.002 x 650 x 810 mm
- Lieferung erfolgt unmontiert
- inkl. Einsätze
- dimensions: 1.002 x 650 x 810 mm
- delivery unmounted
- incl. inserts

Kegelgröße / Shank size	Plätze / Tool seats	kg	Art.-Nr. / Order no.
SK 30 / BT 30	32	51	● WZ-WW-SK30
SK 40 / BT 40	28	51	● WZ-WW-SK40
SK 50 / BT 50	20	51	● WZ-WW-SK50
HSK 63	24	51	● WZ-WW-HSK63

Montagehilfen Assembly supports



Montagehilfe, Aluminium Assembly support, aluminium

A mm	B mm	Für / For	Art.-Nr. / Order no.
80	75	ISO-DIN-CAT-BT30	09-TAL30
90	85	ISO-DIN-CAT-BT40	09-TAL40
120	115	ISO-DIN-CAT-BT50	09-TAL50

Montageblock, schwenkbar Assembly support, tiltable

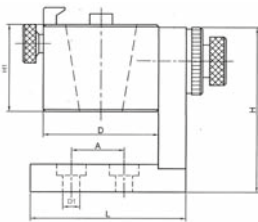

Größe / Size	D mm	H1 mm	D1 mm	H mm	A mm	L mm	Art.-Nr. / Order no.
SK 30 / BT 30	88	50	11	132	55	111	47-MBSK-30
SK 40 / BT 40	93	57	11	132	55	111	47-MBSK-40
SK 50 / BT 50	118	62	11	176	55	111	47-MBSK-50
VDI 16	78	50	11	132	55	111	47-MBS-16
VDI 20	83	50	11	132	55	111	47-MBS-20
VDI 25	93	57	11	132	55	111	47-MBS-25
VDI 30	93	57	11	132	55	111	47-MBS-30
VDI 40	102	57	11	132	55	111	47-MBS-40
VDI 50	118	62	11	132	55	111	47-MBS-50
HSK 40	88	50	11	132	55	111	47-MBHSK-40
HSK 50	93	57	11	132	55	111	47-MBHSK-50
HSK 63	98	57	11	132	55	111	47-MBHSK-63
HSK 100	135	62	11	132	55	111	47-MBHSK-100

Montageblock DIN / ISO / BT Assembly support DIN / ISO / BT

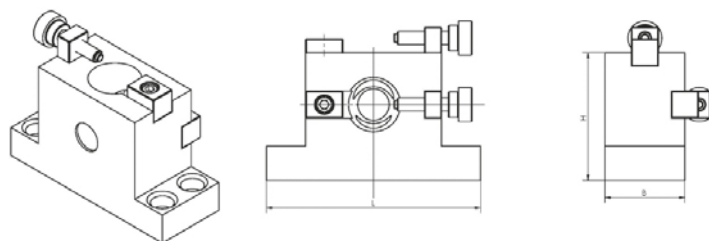

Größe / Size	H mm	B mm	L mm	Art.-Nr. / Order no.
SK 30 / BT 30	75	47	126	09-MBW-30
SK 40 / BT 40	104	63	161	09-MBW-40
SK 50 / BT 50	155	98	182	09-MBW-50

13
133

Zubehör für Steilkegelaufnahmen / Accessories for SK tooling



Lagerstandard / in stock
innerhalb weniger Tage / within a few days
auf Anfrage / on request
auslaufende Größe / as stock lasts

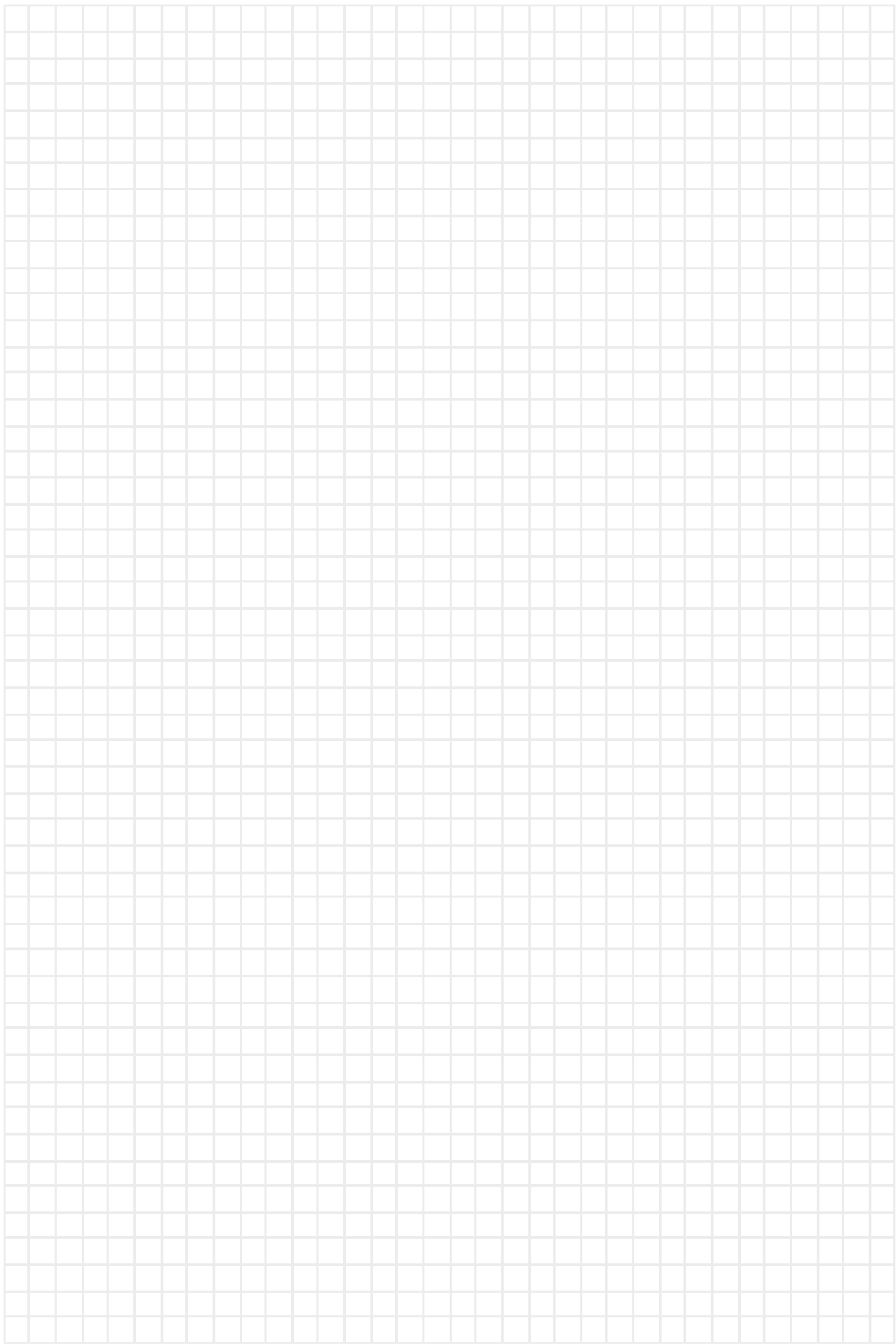

Messen - Prüfen - Einstellen

Measuring - Testing - Positioning



■ Inhalt:

14.1 | Messen - Prüfen - Einstellen

- | Prüfdorne
- | Nulleinsteller
- | Kantentaster
- | Messuhren
- | Innen-Messschraubensätze
- | Gelenkstativ, magnetisch
- | Parallelunterlagen
- | Endmaßsätze im Holzkasten
- | Messstift-Sätze
- | Grenz- und Gewindelehrdorne und Ringe
- | Spannkraftmessgeräte
- | Anzugskraftmessgeräte

14.2 | Aufspannsätze und Fräserkassetten

■ Content:

14.1 | Measuring - Testing - Positioning

- | Test arbors
- | Zero adjusters
- | Edge finders
- | Dial indicators
- | Internal micrometer sets
- | Magnetic stands
- | Parallels
- | Gauge block sets in wooden case
- | Pin gauge sets
- | Plain and thread plug gauges and rings
- | Clamping force meters
- | Clamping torque meters

14.2 | Clamping sets and milling cutter sets

Prüfdorne Test arbors



DIN 69871 (SK)* DIN 69871 (SK)*

Größe / Size	L mm	D mm	Art.-Nr. / Order no.
SK 30	275	32	▶ 09-PD-SK30
SK 40	269	40	▶ 09-PD-SK40
SK 50	267	50	▶ 09-PD-SK50



DIN 2080* DIN 2080*

Größe / Size	L mm	D mm	Art.-Nr. / Order no.
SK 30	275	32	▶ 09-PD-ISO30
SK 40	275	40	▶ 09-PD-ISO40
SK 50	275	50	▶ 09-PD-ISO50



MAS BT* MAS BT*

Größe / Size	L mm	D mm	Art.-Nr. / Order no.
BT 30	275	32	▶ 09-PD-BT30
BT 40	269	40	▶ 09-PD-BT40
BT 50	274	40	▶ 09-PD-BT50

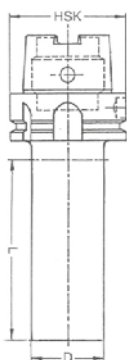

DIN 69893 (HSK)* DIN 69893 (HSK)*

Größe / Size	L mm	D mm	Art.-Nr. / Order no.
HSK 32	170	25	▶ 09-PD-HSK32
HSK 40	170	25	▶ 09-PD-HSK40
HSK 50	200	32	▶ 09-PD-HSK50
HSK 63	300	40	▶ 09-PD-HSK63
HSK 80	300	40	▶ 09-PD-HSK80
HSK 100	280	50	▶ 09-PD-HSK100

* - Lieferung im Holzetui, kalibriert
- Rundlaufgenauigkeit: 0,003 mm
- Zylindrizität: 0,003 mm

* - supplied in wooden case, calibrated
- concentricity: 0,003 mm
- cylindricity: 0,003 mm

Prüfdorne Test arbors



DIN 229 (MK)** DIN 229 (MT)**

Größe / Size	L mm	D mm	Art.-Nr. / Order no.
MK 3	250	25	09-PD-MK3
MK 4	300	32	09-PD-MK4
MK 5	300	40	09-PD-MK5
MK 6	300	50	09-PD-MK6



Zylindrisch** Cylindrical**

Größe / Size	L mm	Art.-Nr. / Order no.
Zyl. / Cyl. 32	300	09-PD-ZYL32
Zyl. / Cyl. 35	400	09-PD-ZYL35
Zyl. / Cyl. 40	500	09-PD-ZYL40
Zyl. / Cyl. 50	600	09-PD-ZYL50



DIN 69880 (VDI)** DIN 69880 (VDI)**



VDI	D mm	D1 mm	L mm	B mm	Art.-Nr. / Order no.
16	30	40	120	15	83-PD-16-30
20	40	50	150	15	83-PD-20-40
25	40	58	150	15	83-PD-25-40
30	40	68	200	15	83-PD-30-40
40	40	83	200	15	83-PD-40-40
50	40	98	200	15	83-PD-50-40

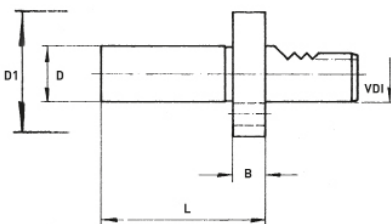

** - Holzetui und Kalibrierschein auf Anfrage

** - wooden case and calibration certificate upon request

Nulleinsteller Zero adjusters



Nulleinsteller mit integrierter Messuhr Zero adjusters with integrated dial indicator

- zur Erfassung des Werkstücknullpunktes
- mit Messuhr \varnothing 40 mm
- mit Magnetfuß
- for determination of the work piece's zero point
- with dial indicator \varnothing 40 mm
- with magnetic base

Abmessungen / Dimension mm	Ablesung / Reading mm	Art.-Nr. / Order no.
61 x 54 x 52	2 x 0,01	<input checked="" type="checkbox"/> 42-X50M

Nulleinsteller mit externer Messuhr Zero adjusters with external dial indicator

- zur Erfassung des Werkstücknullpunktes
- mit Messuhr \varnothing 40 mm
- for determination of the work piece's zero point
- with dial indicator \varnothing 40 mm



Magnetfuß / Magnetic base	Abmessungen / Dimension mm	Ablesung / Reading mm	Art.-Nr. / Order no.
ohne / without	58 x 50	3 x 0,01	<input checked="" type="checkbox"/> 42-00502
mit / with	58 x 50	3 x 0,01	<input checked="" type="checkbox"/> 42-00502M

Kantentaster, mechanisch Edge finders, mechanical



Im Aluminiumkoffer / In aluminium case

Abmessungen / Dimension mm	Art.-Nr. / Order no.
93 x 10 x 10	42-1010-A
92 x 10 x 10 x 4 (abgesetzt / stepped)	42-10104-A

In Plastikhülse / In plastic case

Abmessungen / Dimension mm	Art.-Nr. / Order no.
93 x 10 x 10	42-1010-N
92 x 10 x 10 x 4 (abgesetzt / stepped)	42-10104-N

Ersatzfedern / Set of spare springs

	Art.-Nr. / Order no.
Satz à 10 Stück / Set of 10 pieces	42-1010F

Leere Boxen siehe Seite 204
Empty boxes see page 204

Kantentaster, elektronisch Edge finders, electronical

- LED-Anzeige
- gehärtet und präzisionsgeschliffen
- Rundlauf 0,01 mm
- LED display
- hardened and precision ground
- concentricity 0,01 mm

In Plastikhülse / In plastic case

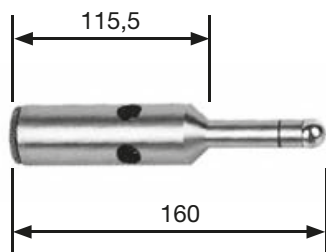

Abmessungen / Dimension mm	Art.-Nr. / Order no.
115,5 x 20 x 10	01-129055-N

14
14.1

Messuhren Dial indicators



Messuhren, Standard Dial indicators, standard

- nach DIN 878
 - Aufnahme Ø 8H6
 - edelsteingelagert, für Langlebigkeit und Genauigkeit
 - Metallgehäuse mit Toleranzmarkern
- according to DIN 878
 - shank Ø 8H6
 - jeweled bearing for durability and stability
 - metal housing with tolerance markers

Messbereich / Range mm	Ablesung / Reading mm	Gehäuse Ø / Housing Ø mm	Art.-Nr. / Order no.
3	0,01	40	* 58-MU-3/0,01
5	0,01	40	* 58-MU-5/0,01
10	0,01	40	● 58-MU-10/0,01KAL*

* inkl. Kalibrierschein / with calibration certificate

Messuhr, wasser- und öldicht Dial indicator, liquid resistant



- nach Werksnorm
 - Aufnahme Ø 8H6
 - Wasser- und öldicht
 - Metallgehäuse
- according to manufacturer standard
 - shank Ø 8H6
 - liquid resistant
 - metal housing

Messbereich / Range mm	Ablesung / Reading mm	Gehäuse Ø / Housing Ø mm	Art.-Nr. / Order no.
10	0,01	60	● 58-MU-10/0,01WP

14
14.1

Messen - Prüfen - Einstellen / Measuring - Testing - Positioning



Messuhren Dial indicators

Typ 1 / Type 1

Typ 2 / Type 2

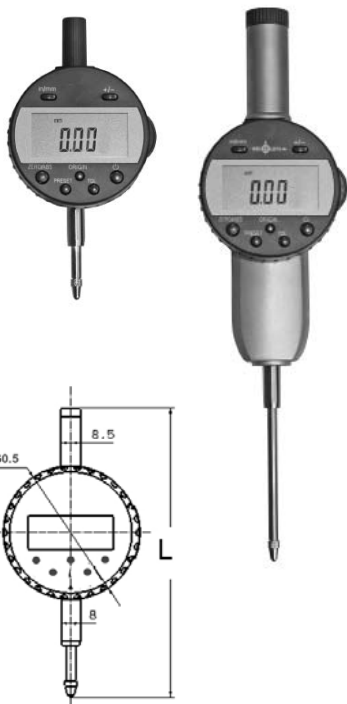

Messuhren, digital Dial indicators, digital

- mit Digitalanzeige (LCD)
- inkl. 3V Batterie
- Aufnahme \varnothing 8H6
- mit Datenausgang RS232 (RB6)
- with digital display (LCD)
- incl. 3V battery
- shank \varnothing 8H6
- with data output RS232 (RB6)

Messbereich / Range mm	Ablesung / Reading mm	Genauigkeit / Accuracy mm	Gehäuse \varnothing / Housing \varnothing mm	L mm	Typ / Type	Art.-Nr. / Order no.
25	0,01	0,01	60,5	131	1	58-DMU-25/0,01
50	0,01	0,015	60,5	244	2	58-DMU-50/0,01

Fühlhebelmessgerät Dial test indicator



- nach DIN 2270
- stoßgeschützt
- Messeinsatz \varnothing 2 mm (Hartmetall)
- mit Schwalbenschwanzführung
- für Einspannschaft \varnothing 6 mm und \varnothing 8 mm
- according to DIN 2270
- shock proof
- carbide tipped probe \varnothing 2 mm
- with dovetail guide
- incl. clamping shaft for \varnothing 6 mm and \varnothing 8 mm

Messbereich / Range mm	Ablesung / Reading mm	Gehäuse \varnothing / Housing \varnothing mm	Messeinsatzlänge / Probe length mm	Art.-Nr. / Order no.
0,8	0,01	38	11,6	58-FHM-0,08/0,01

14
14.1

Messen - Prüfen - Einstellen / Measuring - Testing - Positioning



Innen-Messschraubensätze Internal micrometer sets

Innen-Messschraubensätze Internal micrometer sets



- zur Messung von Sacklochbohrungen
- inkl. Skala und Feineinstellung
- mit Einstellring und Verlängerung
- for measuring of blind holes
- incl. scale and fine adjustment
- with setting gauge and extension

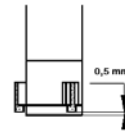
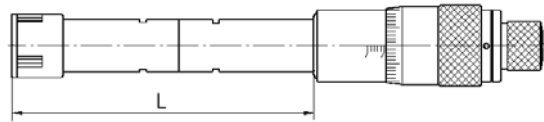

Messbereich / Range mm	Einstellringe / Setting gauges mm	Verlängerungen / Extensions mm	Anzahl Mess- schrauben / Amount of micrometers	Ablesung / Reading mm	Genauigkeit / Accuracy mm	L mm	Art.-Nr. / Order no.
6 - 12	6 + 8 + 10	100 x Ø 5,7	3	0,001	0,004	55	▶ 58-IMS-S12
12 - 20	16	150 x Ø 11,7	2	0,005	0,005	81	▶ 58-IMS-S20
20 - 50	25 + 40	150 x Ø 11,7 150 x Ø 23,4	4	0,005	0,005	91 101	▶ 58-IMS-S50
50 - 100	62 + 87	150 x Ø 23,4	4	0,005	0,005	115	▶ 58-IMS-S100

Gelenkstativ, magnetisch Magnetic stands



Magnetisches Gelenkstativ, mechanische Ausführung Magnetic stand, mechanical type

- mit Feineinstellung
- für Messuhren mit Aufnahme Ø 8 mm
- mit An- / Ausschalter
- with fine adjustment
- for dials with shank Ø 8 mm
- with on- / off-switch

Magnetkraft / Magnetic force kg	Magnetfuß / Base mm	Armlänge / Stem length mm	Art.-Nr. / Order no.
60	59 x 50 x 55	345	● 58-MST-345

Parallelunterlagen Parallels

Material: Legierter Werkzeugstahl
53 - 57 HRC
Toleranzen: A = 0,01 mm
B = 0,005 mm

Material: Alloyed tool steel
53 - 57 HRC
Tolerance: A = 0,01 mm
B = 0,005 mm

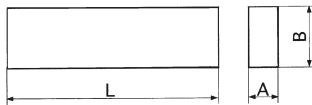

Im Holzkasten In wooden case

L mm	A mm	B mm	Menge / Quantity	Paare / Pairs	Art.-Nr. / Order no.
100	4	10/14/18/22/26 30/34/38/42	je 2 / 2 each	9	13-MLRD-100/4
120	8	12/17/22/25 28/32/36/38	je 2 / 2 each	8	13-MLRD-120/8
160	4	10/14/18/22/26 30/34/38/42	je 2 / 2 each	9	13-MLRD-160/4
160	8	12/17/22/25 28/32/36/38	je 2 / 2 each	8	13-MLRD-160/8
200	8	17/22/26/28 32/36/38/42	je 2 / 2 each	8	13-MLRD-200/8

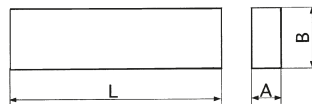

Im Holzkasten In wooden case

L mm	A mm	B mm	Menge / Quantity	Paare / Pairs	Art.-Nr. / Order no.
120	10	14/16/18/20/22/ 24/26/28/ 30/32/35/40	je 2 / 2 each	12	13-PUS-120/10
150	10	14/16/18/20/22/24/ 26/28/30/32/ 35/40/45/50	je 2 / 2 each	14	13-PUS-150/10

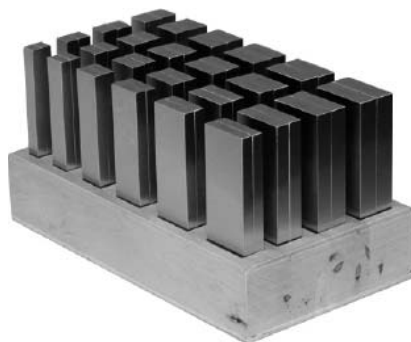

Im Holzständer, 56-62 HRC In wooden tray, 56-62 HRC

L mm	B x A mm	Menge / Paare / Quantity Pairs	Art.-Nr. / Order no.
100*	5x2/10x2/15x2/20x2/6x3/11x3/16x3/21x3/ 7x4/12x4/17x4/22x4/8x5/13x5/18x5/23x5/ 9x6/14x6/19x6/24x6	je 2 / 2 each	20
125	11x8/16x8/21x8/26x8/31x8/36x8/13x10/ 18x10/23x10/28x10/33x10/38x10/15x12/ 20x12/25x12/30x12/35x12/40x12/17x14/ 22x14/27x14/32x14/37x14/42x14	je 2 / 2 each	24
150	11x8/16x8/21x8/26x8/31x8/36x8/ 13x10/18x10/23x10/28x10/33x10/38x10/ 15x12/20x12/25x12/30x12/35x12/40x12/ 17x14/22x14/27x14/32x14/37x14/42x14	je 2 / 2 each	24

* in Holzkasten
* in wooden case

14
14.1

Parallelunterlagen / Parallels



Lagerstandard / in stock
innerhalb weniger Tage / within a few days
auf Anfrage / on request
auslaufende Größe / as stock lasts

279

Endmaßsätze im Holzkasten

Gauge block sets in wooden case

- nach DIN EN ISO 3650
- according to DIN EN ISO 3650

Stahl / Steel

- aus gehärtetem Spezialstahl
- made of hardened special steel



Stahl / Steel

Menge / Quantity	Größe / Size mm	Schritte / Steps mm	Stücke / Pieces	Güte / Grade	Art.-Nr. / Order no.
32	1,005	-	1	0	● 13-EMS-32/0
	1,01 - 1,09	0,01	9		
	1,1 - 1,9	0,1	9		
	1 - 9	1	9		
	10 - 30	10	3		
	50	-	1	1	● 13-EMS-32/1
47	1,005	-	1	0	● 13-EMS-47/0
	1,01 - 1,2	0,01	20		
	1,3 - 1,9	0,1	7		
	1 - 9	1	9		
	10 - 100	10	10	1	● 13-EMS-47/1
87	1,001 - 1,009	0,001	9	0	● 13-EMS-87/0
	1,01 - 1,49	0,01	49		
	0,5 - 9,5	0,5	19		
	10 - 100	10	10		
103	1,0005	-	1	0	● 13-EMS-103/0
	1,01 - 1,49	0,001	49		
	0,5 - 24,5	0,5	49		
	25 - 100	25	4		

* inkl. Kalibrierschein / with calibration certificate

Hartmetall / Carbide



Hartmetall / Carbide

Menge / Quantity	Größe / Size mm	Schritte / Steps mm	Stücke / Pieces	Güte / Grade	Art.-Nr. / Order no.
32	1,005	-	1	0	▶ 13-EMHM-32/0
	1,01 - 1,09	0,01	9		
	1,1 - 1,9	0,1	9		
	1 - 9	1	9		
	10, 20, 30, 50	10	4		
	10 - 100	10	10	1	▶ 13-EMHM-32/1
47	1,005	-	1	0	▶ 13-EMHM-47/0
	1,01 - 1,2	0,01	20		
	1,3 - 1,9	0,1	7		
	1 - 9	1	9		
	10 - 100	10	10	1	▶ 13-EMHM-47/1
87	1,001 - 1,009	0,001	9	0	▶ 13-EMHM-87/0
	1,01 - 1,49	0,01	49		
	0,5 - 9,5	0,5	19		
	10 - 100	10	10		
	10 - 100	10	10	1	▶ 13-EMHM-487/1

Keramik / Ceramic

- antimagnetisch
- antimagnetic
- doppelt so hart wie Stahl
- twice as hard as steel



Keramik / Ceramic

Menge / Quantity	Größe / Size mm	Schritte / Steps mm	Stücke / Pieces	Güte / Grade	Art.-Nr. / Order no.
32	1,005	-	1	0	▶ 13-EMK-32/0
	1,01 - 1,09	0,01	9		
	1,1 - 1,9	0,1	9		
	1 - 9	1	9		
	10 - 30, 50	10	4		
	10 - 100	10	10	1	▶ 13-EMK-32/1
47	1,005	-	1	0	▶ 13-EMK-47/0
	1,01 - 1,2	0,01	20		
	1,3 - 1,9	0,1	7		
	1 - 9	1	9		
	10 - 100	10	10	1	▶ 13-EMK-47/1



Endmaßsätze im Holzkasten / Gauge block sets in wooden case

14
14.1

Messstift-Sätze

Pin gauge sets

Messstift-Sätze

Pin gauge sets

- Genauigkeit +/- 0,002 mm

- accuracy +/- 0,002 mm



Typ 1 / Type 1



Typ 2 / Type 2

Messbereich / Range mm	Steigung / Stepping mm	Anzahl d. Stifte / Number of pins	Typ / Type	Art.-Nr. / Order no.
0,20 - 0,50	0,01	31	1	▶ 58-PSS-0,5
0,50 - 1,00	0,01	51	2	▶ 58-PSS-1,0
1,01 - 2,00	0,01	100	2	▶ 58-PSS-2,0
2,01 - 3,00	0,01	100	2	▶ 58-PSS-3,0
3,01 - 4,00	0,01	100	2	▶ 58-PSS-4,0
4,01 - 5,00	0,01	100	2	▶ 58-PSS-5,0
5,01 - 6,00	0,01	100	2	▶ 58-PSS-6,0
6,01 - 7,00	0,01	100	2	▶ 58-PSS-7,0
7,01 - 8,00	0,01	100	2	▶ 58-PSS-8,0
8,01 - 9,00	0,01	100	2	▶ 58-PSS-9,0
9,01 - 10,00	0,01	100	2	▶ 58-PSS-10,0

Grenz- und Gewindelehndorne und Ringe Plain and thread plug gauges and rings

Grenzlehndorne Plain plug gauges

- Maße nach DIN 2245
- Gehärteter Lehenstahl

- dimensions according to DIN 2245
- hardened gauge steel



kalibrierte Ausführung calibrated version

Größe / Size Ø mm	Art.-Nr. / Order no.
2	58-ESD-2
3	58-ESD-3
4	58-ESD-4
5	58-ESD-5
6	58-ESD-6
7	58-ESD-7
8	58-ESD-8
9	58-ESD-9
10	58-ESD-10
11	58-ESD-11
12	58-ESD-12
13	58-ESD-13
14	58-ESD-14
15	58-ESD-15
16	58-ESD-16
17	58-ESD-17
18	58-ESD-18
19	58-ESD-19
20	58-ESD-20
21	58-ESD-21
22	58-ESD-22
23	58-ESD-23
24	58-ESD-24
25	58-ESD-25
26	58-ESD-26
28	58-ESD-28
30	58-ESD-30
32	58-ESD-32

Größe / Size Ø mm	Art.-Nr. / Order no.
33	58-ESD-33
34	58-ESD-34
35	58-ESD-35
36	58-ESD-36
37	58-ESD-37
38	58-ESD-38
40	58-ESD-40
42	58-ESD-42
44	58-ESD-44
45	58-ESD-45
46	58-ESD-46
47	58-ESD-47
48	58-ESD-48
50	58-ESD-50
52	58-ESD-52
55	58-ESD-55
60	58-ESD-60
62	58-ESD-62
65	58-ESD-65
68	58-ESD-68
70	58-ESD-70
72	58-ESD-72
75	58-ESD-75
80	58-ESD-80
85	58-ESD-85
90	58-ESD-90
95	58-ESD-95
98	58-ESD-98
100	58-ESD-100

Größe / Size Ø mm	Art.-Nr. / Order no.
2	58-ESD-2KAL
3	58-ESD-3KAL
4	58-ESD-4KAL
5	58-ESD-5KAL
6	58-ESD-6KAL
7	58-ESD-7KAL
8	58-ESD-8KAL
9	58-ESD-9KAL
10	58-ESD-10KAL
11	58-ESD-11KAL
12	58-ESD-12KAL
13	58-ESD-13KAL
14	58-ESD-14KAL
15	58-ESD-15KAL
16	58-ESD-16KAL
17	58-ESD-17KAL
18	58-ESD-18KAL
19	58-ESD-19KAL
20	58-ESD-20KAL
22	58-ESD-22KAL
23	58-ESD-23KAL
24	58-ESD-24KAL
25	58-ESD-25KAL
26	58-ESD-26KAL
28	58-ESD-28KAL
30	58-ESD-30KAL
32	58-ESD-32KAL
35	58-ESD-35KAL
40	58-ESD-40KAL
45	58-ESD-45KAL
50	58-ESD-50KAL
60	58-ESD-60KAL

Grenzlehndornsatz Set of plain plug gauges



Größe / Size
Ø mm

Art.-Nr. /
Order no.

3, 4, 5, 6, 8, 10, 12

58-ESD-SATZ

- Lagerstandard / in stock
- ▶ innerhalb weniger Tage / within a few days
- auf Anfrage / on request
- * auslaufende Größe / as stock lasts



Grenz- und Gewindelehrdorne und Ringe

Plain and thread plug gauges and rings



Grenzlehrringe

Plain setting ring gauges

- nach DIN 2250C
- Genauigkeit DIN 286, JS 3
- gehärteter Lehenstahl

- according to DIN 2250C
- accuracy DIN 286, JS 3
- hardened gauge steel

kalibrierte Ausführung

calibrated version

Größe / Size Ø mm	Art.-Nr. / Order no.
3	58-ESR-3
4	58-ESR-4
5	58-ESR-5
6	58-ESR-6
7	58-ESR-7
8	58-ESR-8
9	58-ESR-9
10	58-ESR-10
11	58-ESR-11
12	58-ESR-12
13	58-ESR-13
14	58-ESR-14
15	58-ESR-15
16	58-ESR-16
17	58-ESR-17
18	58-ESR-18
19	58-ESR-19
20	58-ESR-20
21	58-ESR-21
22	58-ESR-22
23	58-ESR-23
24	58-ESR-24
25	58-ESR-25
26	58-ESR-26
28	58-ESR-28

Größe / Size Ø mm	Art.-Nr. / Order no.
30	58-ESR-30
32	58-ESR-32
34	58-ESR-34
35	58-ESR-35
36	58-ESR-36
37	58-ESR-37
38	58-ESR-38
40	58-ESR-40
42	58-ESR-42
44	58-ESR-44
45	58-ESR-45
46	58-ESR-46
47	58-ESR-47
48	58-ESR-48
50	58-ESR-50
55	58-ESR-55
60	58-ESR-60
65	58-ESR-65
70	58-ESR-70
75	58-ESR-75
80	58-ESR-80
85	58-ESR-85
90	58-ESR-90
95	58-ESR-95
100	58-ESR-100

Größe / Size Ø mm	Art.-Nr. / Order no.
3	58-ESR-3KAL
4	58-ESR-4KAL
5	58-ESR-5KAL
6	58-ESR-6KAL
7	58-ESR-7KAL
8	58-ESR-8KAL
10	58-ESR-10KAL
11	58-ESR-12KAL
14	58-ESR-14KAL
15	58-ESR-15KAL
16	58-ESR-16KAL
18	58-ESR-18KAL
19	58-ESR-19KAL
20	58-ESR-20KAL
22	58-ESR-22KAL
24	58-ESR-24KAL
25	58-ESR-25KAL
26	58-ESR-26KAL
28	58-ESR-28KAL
30	58-ESR-30KAL
32	58-ESR-32KAL
34	58-ESR-34KAL
35	58-ESR-35KAL
36	58-ESR-36KAL
38	58-ESR-38KAL
40	58-ESR-40KAL
42	58-ESR-42KAL
45	58-ESR-45KAL
46	58-ESR-46KAL
47	58-ESR-47KAL
48	58-ESR-48KAL
50	58-ESR-50KAL
55	58-ESR-55KAL
60	58-ESR-60KAL
65	58-ESR-65KAL
70	58-ESR-70KAL
75	58-ESR-75KAL
80	58-ESR-80KAL
85	58-ESR-85KAL
90	58-ESR-90KAL
95	58-ESR-95KAL
100	58-ESR-100KAL

14
14.1

Grenz- und Gewindelehrdorne und Ringe / Plain and thread plug gauges and rings



Grenz- und Gewindelehndorne und Ringe Plain and thread plug gauges and rings

Gewindelehndorne, „Gut“ und „Ausschuss“ Thread plug gauges, „GO“ and „NO GO“



- nach DIN 13
 - gehärteter Lehrenstahl
 - Toleranz 6H
 - mit Gut- und Ausschusseite
- according to DIN 13
 - hardened gauge steel
 - tolerance 6H
 - with GO and NO GO tips

kalibrierte Ausführung calibrated version

Größe / Size	Art.-Nr. / Order no.
M2	58-GLD-M2
M2,5	58-GLD-M2,5
M3	58-GLD-M3
M4	58-GLD-M4
M5	58-GLD-M5
M6	58-GLD-M6
M7	58-GLD-M7
M8	58-GLD-M8
M9	58-GLD-M9
M10	58-GLD-M10
M11	58-GLD-M11
M12	58-GLD-M12
M14	58-GLD-M14
M16	58-GLD-M16
M18	58-GLD-M18
M20	58-GLD-M20
M22	58-GLD-M22
M24	58-GLD-M24
M30	58-GLD-M30
M33	58-GLD-M33
M36	58-GLD-M36
M42	58-GLD-M42
M45	58-GLD-M45
M48	58-GLD-M48
M60	58-GLD-M60

Größe / Size Ø mm	Art.-Nr. / Order no.
M3	58-GLD-M3KAL
M4	58-GLD-M4KAL
M5	58-GLD-M5KAL
M6	58-GLD-M6KAL
M8	58-GLD-M8KAL
M10	58-GLD-M10KAL
M12	58-GLD-M12KAL
M14	58-GLD-M14KAL
M16	58-GLD-M16KAL
M18	58-GLD-M18KAL
M20	58-GLD-M20KAL

Gewindelehndornsatz, „Gut“ und „Ausschuss“ Set of thread plug gauges, „GO“ and „NO GO“



Größe / Size	Art.-Nr. / Order no.
M3, M4, M5, M6, M8, M10, M12	58-GLD-SATZ

- Lagerstandard / in stock
- ▶ innerhalb weniger Tage / within a few days
- auf Anfrage / on request
- * auslaufende Größe / as stock lasts



14 14.1 Grenz- und Gewindelehndorne und Ringe / Plain and thread plug gauges and rings

Grenz- und Gewindelehrdorne und Ringe Plain and thread plug gauges and rings



Gewindelehrringe, „GUT“ Thread ring gauges, „GO“

- nach DIN 13
- gehärteter Lehenstahl
- Toleranz 6g

- according to DIN 13
- hardened gauge steel
- tolerance 6g

kalibrierte Ausführung calibrated version

Größe / Size	Art.-Nr. / Order no.
M2	58-GLR-M2G
M2,5	58-GLR-M2,5G
M3	58-GLR-M3G
M4	58-GLR-M4G
M5	58-GLR-M5G
M6	58-GLR-M6G
M8	58-GLR-M8G
M10	58-GLR-M10G
M12	58-GLR-M12G
M14	58-GLR-M14G
M16	58-GLR-M16G
M18	58-GLR-M18G
M20	58-GLR-M20G
M24	58-GLR-M24G
M30	58-GLR-M30G
M36	58-GLR-M36G
M48	58-GLR-M48G

Größe / Size Ø mm	Art.-Nr. / Order no.
M3	58-GLR-M3GKAL
M4	58-GLR-M4GKAL
M5	58-GLR-M5GKAL
M6	58-GLR-M6GKAL
M8	58-GLR-M8GKAL
M10	58-GLR-M10GKAL
M12	58-GLR-M12GKAL
M14	58-GLR-M14GKAL
M16	58-GLR-M16GKAL
M18	58-GLR-M18GKAL
M20	58-GLR-M20GKAL

Spannkraftmessgeräte Clamping force meters



Spannkraftmessgeräte für Schraubstöcke Clamping force meters for vices

- zur Überprüfung der Spannkraft an Schraub- und Spannstöcken
- Messbereich: 0,6 kN - 100 kN
- Messgenauigkeit: $\pm 1\%$ des Skaleneuwerts

- to determine the power of clamping devices
- measuring range: 0,6 kN - 100 kN
- precision: $\pm 1\%$ of the end scale value

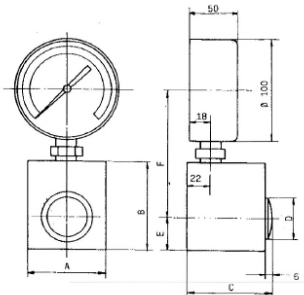

Spannkraft / Gripping force kN	A mm	B mm	C mm	D mm	E mm	F mm	kg	Art.-Nr. / Order no.
0,6-6,0	45	50	45	12	14	108	1,2	14-SKS-S6
1,0-10,0	45	50	45	12	14	108	1,2	14-SKS-S10
1,6-16,0	50	60	50	16	20	112	1,6	14-SKS-S16
2,5-25,0	55	65	55	20	20	117	1,7	14-SKS-S25
4,0-40,0	55	69	55	25	23	114	2,0	14-SKS-S40
6,0-60,0	65	72	65	30	25	119	2,7	14-SKS-S60
10,0-100,0	75	85	85	40	32	125	4,6	14-SKS-S100

Spannkraftmessgeräte Clamping force meters



Spannkraftmessgeräte für Dreibackenfutter Clamping force meters for three-jaw chucks

- Messgenauigkeit: $\pm 1,5\%$ des Skalendendwerts
- Messbereich: 0,6 kN - 400 kN
- Krafteinleitung durch 3 Kolben
- precision $\pm 1,5\%$ of the end scale value
- measuring range: 0,6 - 400 kN
- transmission of force by 3 pistons

Spannkraft / Gripping force kN	Spannkr. p. Backe / Grip. force p. jaw kN	A mm	B mm	C mm	D mm	E mm	F mm	kg	Art.-Nr. / Order no.
0,6-6	3 x 2	40	40	10	12	105	45	0,8	00-SKD3-6
1-10	3 x 3,33	40	40	10	12	105	45	0,8	00-SKD3-10
3-30	3 x 10	40	45	13	15	110	50	1,2	00-SKD3-30
6-60	3 x 20	55	60	20	20	110	60	1,9	00-SKD3-60
9-90	3 x 30	65	70	22	23	120	65	2,5	00-SKD3-90
12-120	3 x 40	65	70	25	26	120	65	2,5	00-SKD3-120
15-150	3 x 50	85	90	30	32	118	70	4,0	00-SKD3-150
18-180	3 x 60	85	90	30	32	118	70	4,0	00-SKD3-180
21-210	3 x 70	95	100	35	37	123	80	5,5	00-SKD3-210
24-240	3 x 80	95	100	35	37	123	85	8,0	00-SKD3-240
30-300	3 x 100	120	125	35	40	125	85	8,0	00-SKD3-300
40-400	3 x 133,3	120	125	35	40	125	85	8,0	00-SKD3-400

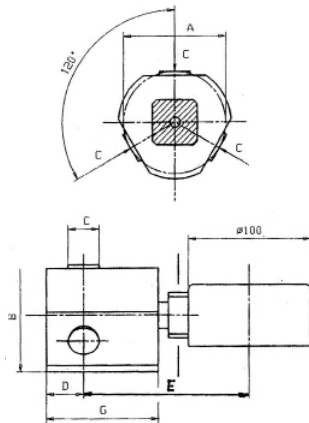

Prüfprotokolle erhältlich auf Anfrage
Test certificates upon request

Spannkraftmessgeräte für Zwei- und Vierbackenfutter auf Anfrage
Clamping force meter for two- and four-jaw chucks upon request

Anzugskraftmessgeräte Tightening force meters

Anzugskraftmessgeräte für Werkzeugspindeln Tightening force meters for spindles

- Lieferung im Holzetui inkl. Kalibrierschein
- delivered in wooden case with calibration certificate



Aufnahme / Mounting	Art.-Nr. / Order no.
SK30 / DIN 69871	14-SKWA-SK30
SK40 / DIN 69871	14-SKWA-SK40
SK50 / DIN 69871	14-SKWA-SK50
HSK 32	14-SKWA-HSK32
HSK 40	14-SKWA-HSK40
HSK 50	14-SKWA-HSK50
HSK 63	14-SKWA-HSK63
HSK 80	14-SKWA-HSK80
HSK 100	14-SKWA-HSK100

Anzugskraftmessgeräte für DIN 2080 und MAS BT auf Anfrage
Tightening force meters for DIN 2080 and MAS BT upon request

Aufspannsätze und Fräserkassetten

Clamping sets and milling cutter sets

Aufspannsätze

Clamping sets

Basissortimente mit den am häufigsten benötigten Spannelementen. Zum schnellen Aufspannen von Werkstücken oder Vorrichtungen auf T-Nutentischen.

Sets of frequently used clamping elements. For fast mounting of work pieces or fixtures on T-groove tables.

Lieferumfang:
6 Nutensteine, 6 Bundmuttern
4 Verbindungsmuttern, 6 gestufte
Spannblockpaare (12 Stk.),
6 Spannpratzen, 24 Gewindebolzen

Scope of supply:
6 T-slot nuts, 6 flange nuts, 4 coupling
nuts, 6 stepped block pairs (12 pcs.),
6 clamps, 24 studs

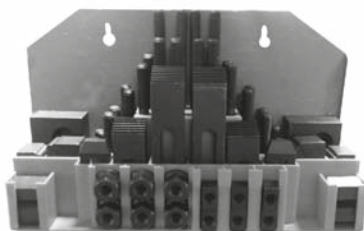

58-tlg., im Display, verwendbar als Wandhalter

58 pcs., in display, usable for wall mounting

Anzugsgewinde / Tightening thread	T-Nutensteine / T-nuts	Art.-Nr. / Order no.
M8	10 mm	11-ASS-M8
M10	12 mm	11-ASS-M10
M12	14 mm	11-ASS-M12
M14	16 mm	11-ASS-M14
M16	18 mm	11-ASS-M16



58-tlg., im Kunststoffkoffer

58 pcs., in plastic case

Anzugsgewinde / Tightening thread	T-Nutensteine / T-nuts	Art.-Nr. / Order no.
M8	10 mm	11-PKS-M8
M10	12 mm	11-PKS-M10
M12	14 mm	11-PKS-M12
M14	16 mm	11-PKS-M14
M16	18 mm	11-PKS-M16



58-tlg., im Holzständer

58 pcs, in wooden tray

Anzugsgewinde / Tightening thread	T-Nutensteine / T-nuts	Art.-Nr. / Order no.
M6	8 mm	11-PKS-M6
M20	22 mm	11-PKS-M20
M24	28 mm	11-PKS-M24

Titan-Fräserkassette, im Kunststoffkoffer

TiN-coated milling cutters, in plastic case

Ausführung nach DIN 327 (2-schneidig) bzw. nach DIN 844B (4-schneidig) je nach Durchmesser, 20-tlg. Satz. 2 - 5 fache Standzeit durch TiN-Beschichtung.

According to DIN 327 (2 flutes) or DIN 844B (4 flutes) depending on the relevant diameter, 20 mills per set. With TiN-coating for increased service life.



Je Ø in DIN 327 und DIN 844B / One drill each in DIN 327 and DIN 844B	Art.-Nr. / Order no.
3 / 4 / 5 / 6 / 8 / 10 / 12 / 14 / 18 / 20 mm	11-TFK-3-20

14
14.2

Aufspannsätze und Fräserkassetten / Clamping sets and milling cutter sets



Lagerstandard / in stock
innerhalb weniger Tage / within a few days
auf Anfrage / on request
auslaufende Größe / as stock lasts

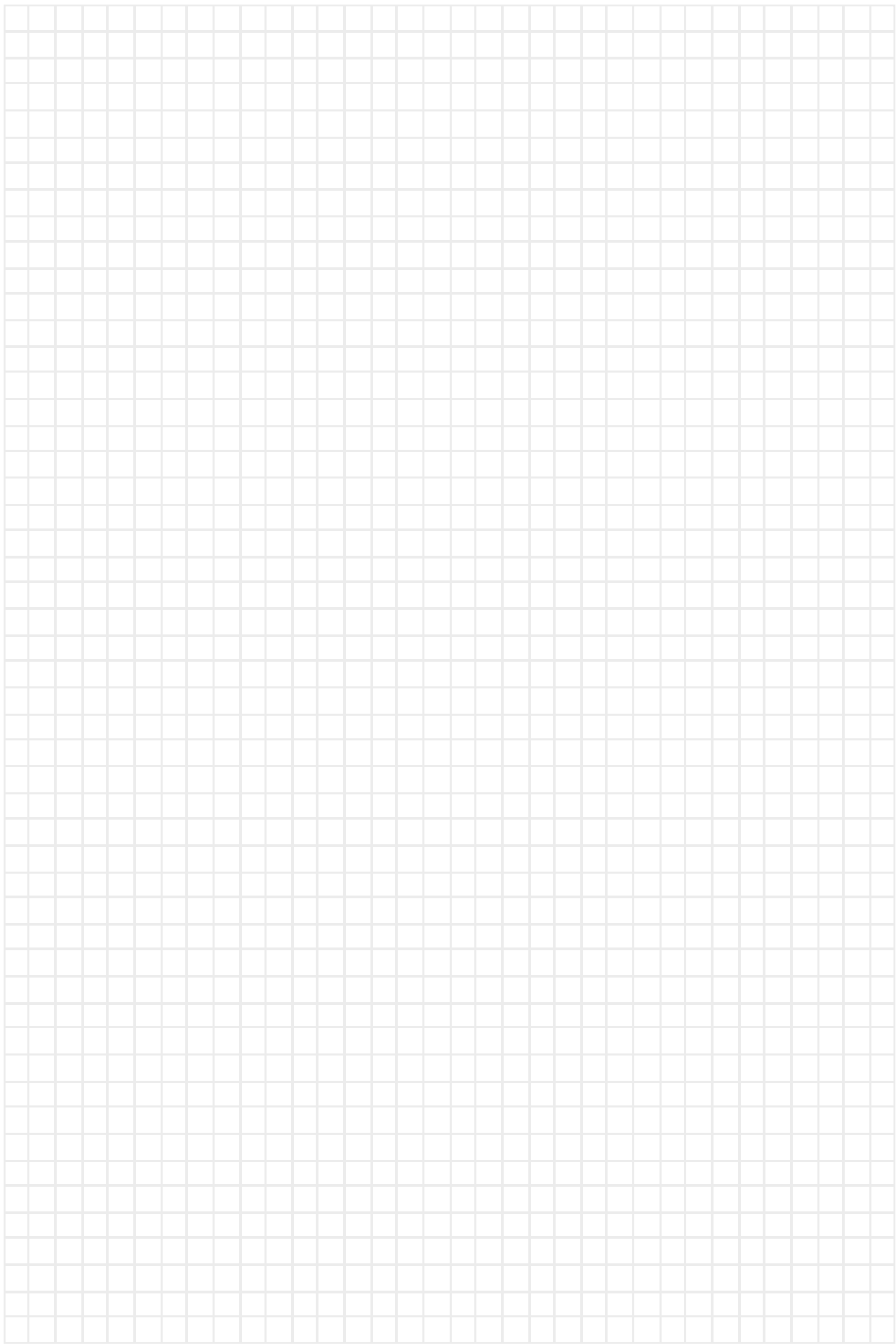

Schutzeinrichtungen, Arbeitsleuchten und Schutzzäune

Safety guards, work lamps and safety panels

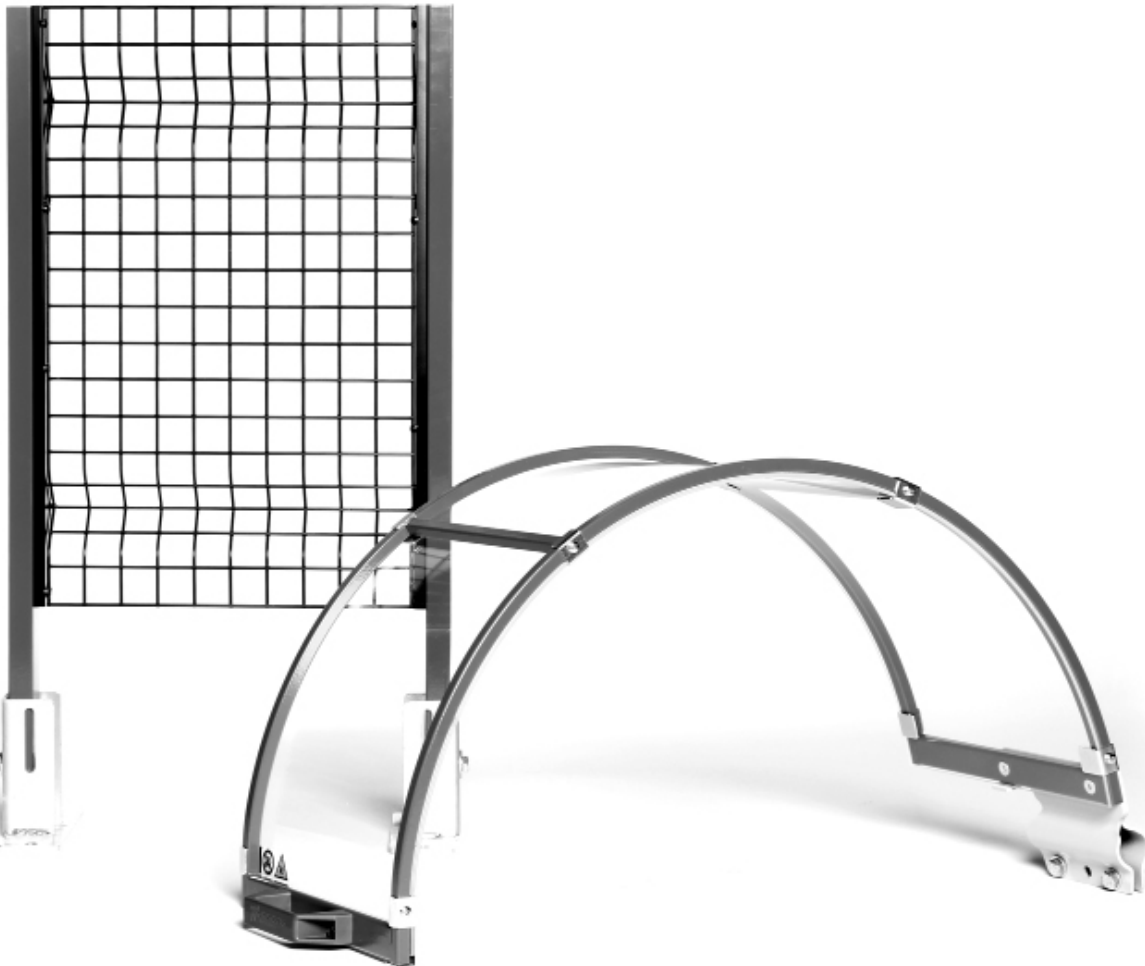

■ Inhalt:

15.1 | Schutzeinrichtungen

- | für Drehmaschinen
- | für Fräsmaschinen
- | für Ständerbohrmaschinen
- | für Schleifmaschinen
- | mit Magnetfuß
- | Not-Aus Steuerungseinheiten

15.2 | Arbeitsleuchten

15.3 | Schutzzäune

■ Content:

15.1 | Safety guards

- | for lathes
- | for milling machines
- | for drilling machines
- | for grinding machines
- | with magnetic base
- | Safety switch control panels

15.2 | Work lamps

15.3 | Safety panels

Futterschutzeinrichtungen, klappbar Safety hoods for chucks, foldable

- aufklappbare Futterschutzhaube aus Acrylglas mit robustem Stahlrahmen
- mit Mikrosicherheitsschalter
- zum Schutz vor Spänen, Spritzwasser und Kühlmittel
- einfache Montage an der Rückseite des Spindelstockes
- verstellbare Halterung
- Durchmesser A der Haube sollte ca. 150-200 mm größer als das Drehfutter sein
- foldable steel-framed hood made from acrylic glass
- with safety micro-switch
- protection against chips, lubricant and coolant
- easy adaption to the back of the spindle
- various adjustments
- diameter A of the safety hood should be 150-200 mm larger than the lathe chuck

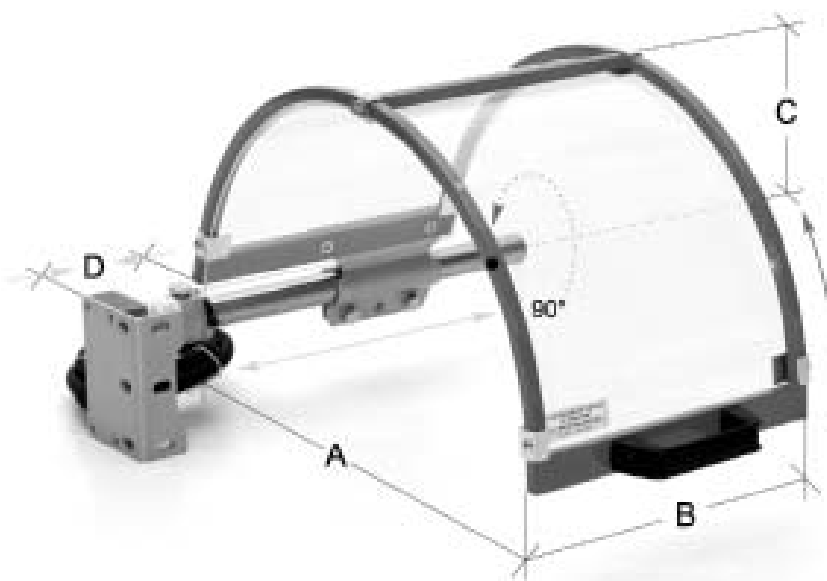

für Futter-Ø / for chuck-Ø	A mm	B mm	C mm	D mm	Art.-Nr. / Order no.
80-140	300	200	180	0-215	● ZE-FS10-300
160-200	400	235	230	0-150	● ZE-FS10-400
250-315	500	235	280	0-150	● ZE-FS10-500
350-400	600	235	330	0-150	● ZE-FS10-600

Zubehör für Schutzeinrichtungen Typ ZE-FS10 Accessories for safety hoods type ZE-FS10

Ersatzschild, ohne Rahmen Spare shield, without steel frame

Für / For	Art.-Nr. / Order no.
ZE-FS10-300	● ZE-FS10-300ES
ZE-FS10-400	● ZE-FS10-400ES
ZE-FS10-500	● ZE-FS10-500ES
ZE-FS10-600	● ZE-FS10-600ES

Ersatzschild, mit Rahmen Spare shield, with steel frame

Für / For	Art.-Nr. / Order no.
ZE-FS10-300	● ZE-FS10-300SC
ZE-FS10-400	● ZE-FS10-400SC
ZE-FS10-500	● ZE-FS10-500SC
ZE-FS10-600	● ZE-FS10-600SC

Futterschutzeinrichtungen für große Futter, klappbar
Safety hoods for big chucks, foldable

- für große Futter bis Ø 1000 mm
 - zum Schutz vor Spänen, Spritzwasser und Kühlmittel
 - mit Mikrosicherheitsschalter
 - verstellbar auf x/y-Weg
 - geteiltes, doppelt aufklappbares Schild aus Aluminium, das ein Öffnen der Vorderseite oder der kompletten Futterschutzeinrichtung ermöglicht
 - Durchmesser A der Haube sollte ca. 150-200 mm größer als das Drehfutter sein
- for chucks up to Ø 1000 mm
 - protection against chips, lubricant and coolant
 - with safety micro-switch
 - fully x-y adjustable
 - semi-circular shield, made from aluminium, divided into two sections to allow either opening of front side only or the entire hood
 - diameter A of the safety hood should be 150-200 mm larger than the lathe chuck

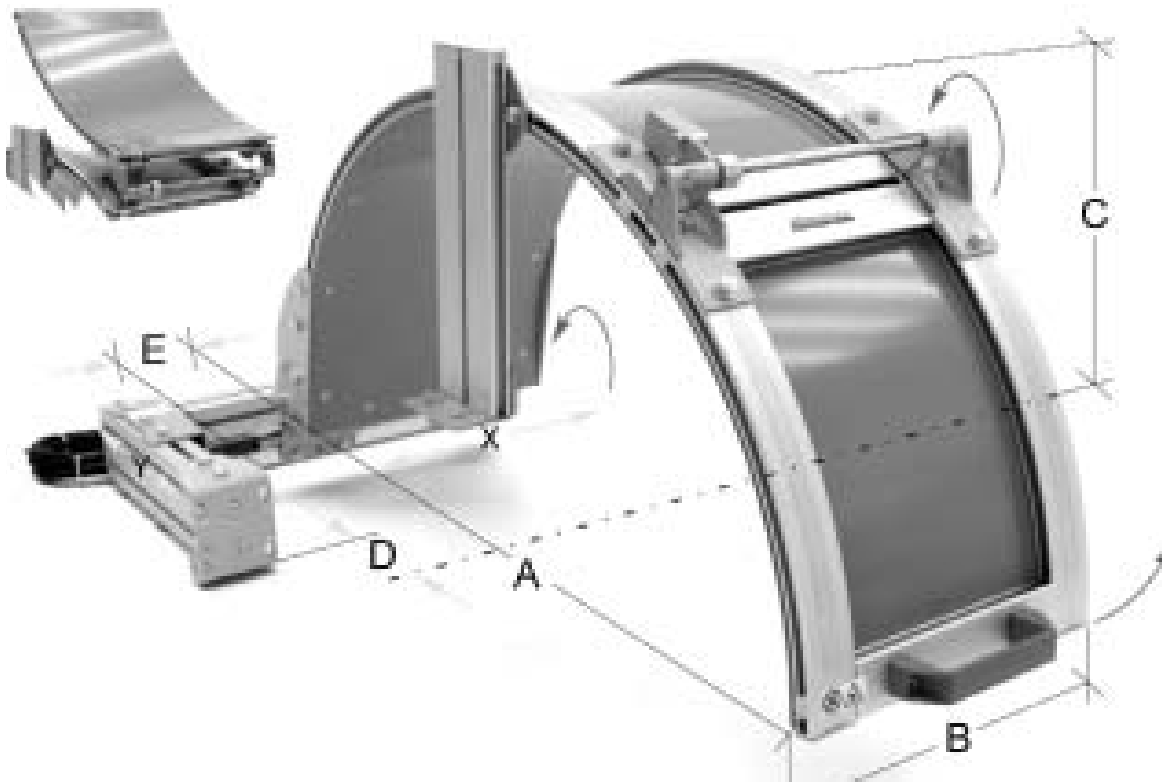

für Futter-Ø /
for chuck-Ø
bis / up to

	A mm	B mm	C mm	D mm	E mm	Art.-Nr. / Order no.
650	800	300	400	165-375	5-120	ZE-FS04-080
850	1000	350	500	265-475	5-70	ZE-FS04-100
1000	1200	350	600	365-575	5-70	ZE-FS04-120

Futterschutzeinrichtungen, verschiebbar
Safety hoods, slidable

- verschiebbare Futterschutzhaube aus Acrylglas mit robustem Stahlrahmen und Führungsschiene aus Aluminium
- mit Mikrosicherheitsschalter
- zum Schutz vor Spänen, Spritzwasser und Kühlmittel
- einfache Montage an der Rückseite des Spindelstockes
- verstellbare Halterung
- Durchmesser C der Haube sollte ca. 150-200 mm größer als das Drehfutter sein
- sliding steel-framed shield made from acrylic glass and auto-carrying guide
- with safety micro-switch
- protection against chips, lubricant and coolant
- easy adaption to the back of the spindle
- various adjustments
- diameter C of the safety hood should be 150-200 mm larger than the lathe chuck

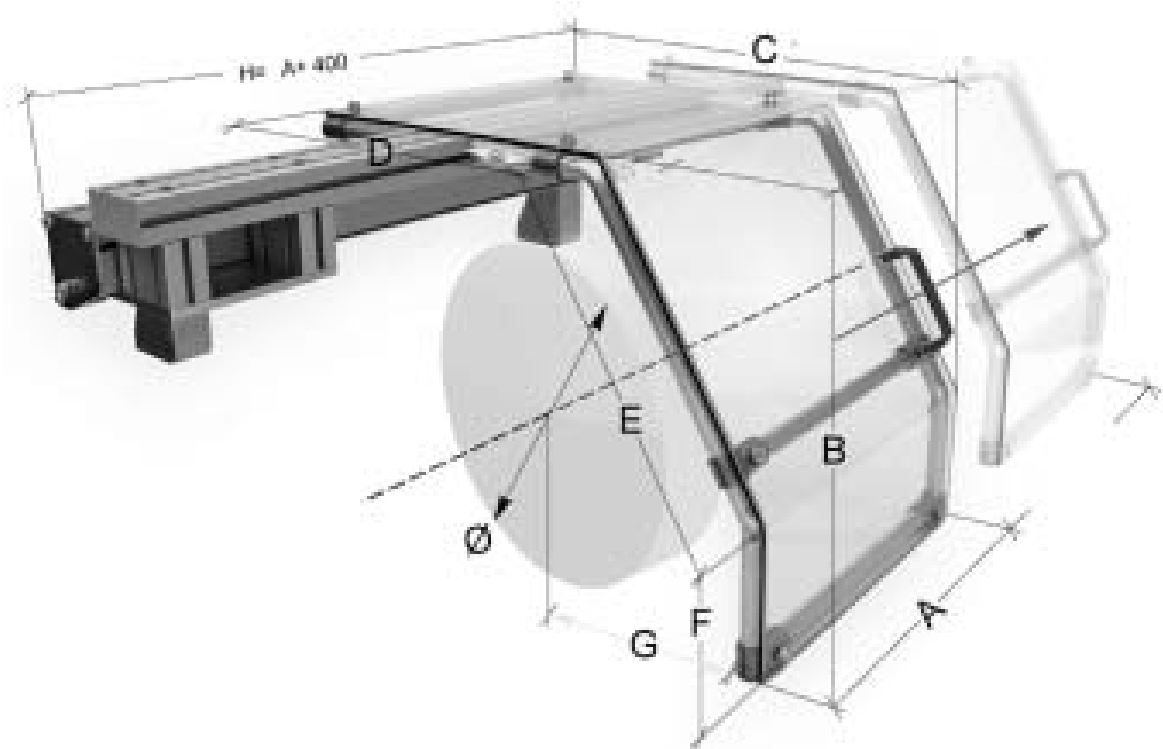

für Futter-Ø / for chuck-Ø	A mm	B mm	C mm	D mm	E mm	F mm	G mm	Art.-Nr. / Order no.
400-500	450	430	655	480	350	125	280-540	● ZE-FS20-400
600-700	450	520	855	640	430	150	320-740	● ZE-FS20-600
800-900	450	640	1065	800	530	180	370-950	● ZE-FS20-800

Schutzeinrichtungen für Drehmaschinen
Lathe carriage safety guards

- mehrfach verstellbar, 180° drehbar
 - zum Schutz vor Spänen, Spritzwasser und Kühlmittel
 - mit Mikrosicherheitsschalter
 - Schutzschild aus Acrylglas
 - Anbringung am Bettschlitten
 - das Schild wird von Gelenkarmen getragen
- *multi-adjustable, 180° rotatable*
 - *protection against chips, lubricant and coolant*
 - *with safety micro-switch*
 - *shield made from acrylic glass*
 - *installation on the longitudinal carriage*
 - *supported by articulated arms*

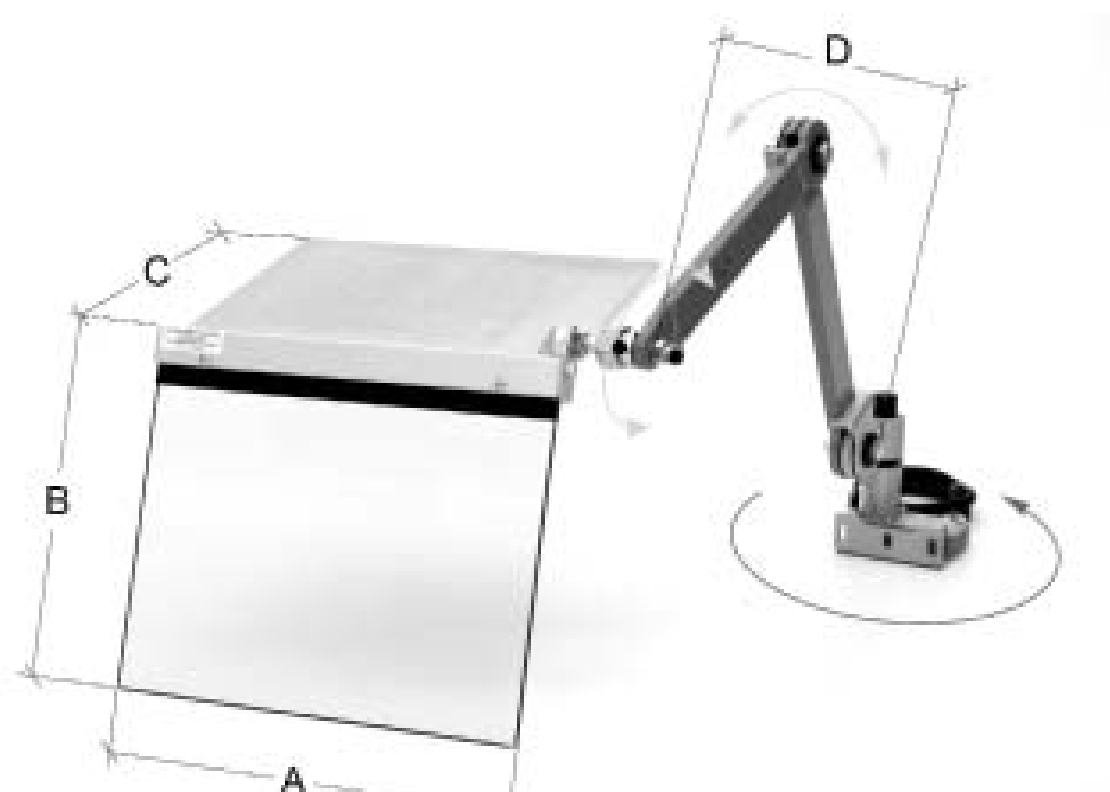

A mm	B mm	C mm	D max. mm	Art.-Nr. / Order no.
350	300	280	550	ZE-FS11-350/550
400	350	310	550	ZE-FS11-400/550
400	350	310	800	ZE-FS12-400/800

Futterschutzeinrichtungen, klappbar
Safety hoods for chucks, tiltable

- Schild öffnet vertikal (Gasdruckfeder)
- mit Mikrosicherheitsschalter
- zum Schutz vor Spänen, Spritzwasser und Kühlmittel
- einfache Montage an der Rückseite des Längsschlittens
- shield opens vertically (gas filled spring)
- with safety micro-switch
- protection against chips, lubricant and coolant
- easy adaption to the longitudinal slide

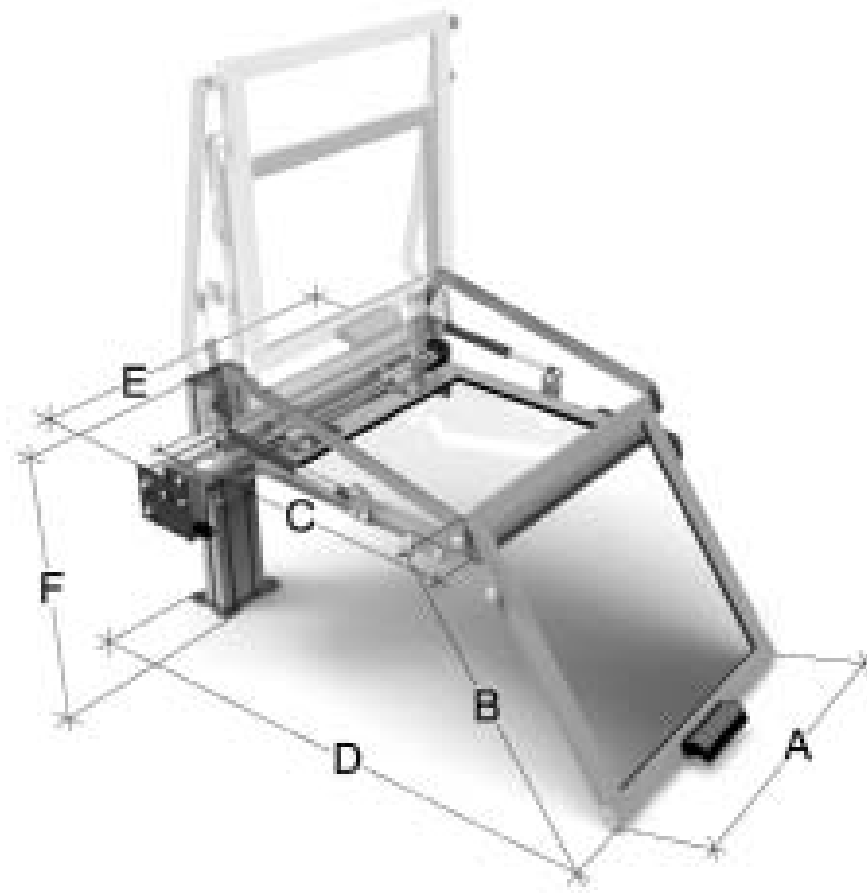

A mm	B mm	C mm	D mm	E mm	F mm	Art.-Nr. / Order no.
450	450	400	760	630	500	● ZE-FSK12-450
850	450	400	760	1030	500	● ZE-FSK12-850
1050	450	400	760	1230	500	▶ ZE-FSK12-1050

Futterschutzeinrichtungen, verschiebbar, extrahoch
Safety hoods, slideable, extra high

- für große Futter bis Ø 1200 mm
 - verschiebbare Futterschutzhaube
 - mit Mikrosicherheitsschalter
 - zum Schutz vor Spänen, Spritzwasser und Kühlmittel
 - einfache Montage an der Oberseite des Spindelstockes
 - Durchmesser C der Haube sollte ca. 150-200 mm größer als das Drehfutter sein
- for chucks up to Ø 1200 mm
 - slideable shield
 - with safety micro-switch
 - protection against chips, lubricant and coolant
 - easy adaption to the head of the machine
 - diameter C of the safety hood should be 150-200 mm larger than the lathe-chuck

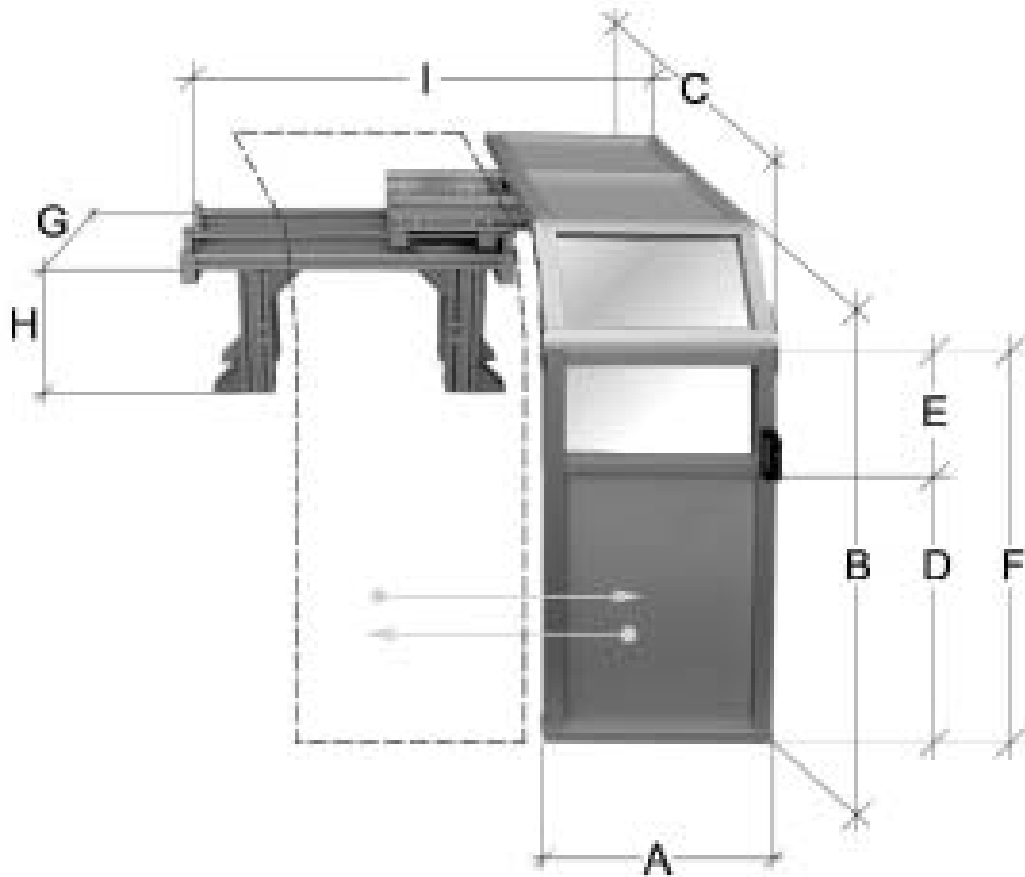

für Futter-Ø / for chuck-Ø	A mm	B mm	C mm	D mm	E mm	F mm	G mm	H mm	I mm	Art.-Nr. / Order no.
800	550	1000	1000	518	282	800	300	390-590	930-1490	<input checked="" type="radio"/> ZE-FS21-1000
1200	550	1500	1400	918	282	1200	300	390-590	930-1490	<input checked="" type="radio"/> ZE-FS21-1500



**Futterschutzeinrichtungen beidseitig,
verschiebbar, extrahoch**
Safety hoods bilateral, slideable, extra high

- für große Futter bis Ø 1200 mm
- verschiebbare Futterschutzhaube, beidseitig
- mit Mikrosicherheitsschalter
- zum Schutz vor Spänen, Spritzwasser und Kühlmittel
- einfache Montage an der Oberseite des Spindelstockes
- Durchmesser C der Haube sollte ca. 150-200 mm größer als das Drehfutter sein
- for chucks up to Ø 1200 mm
- slideable, bilateral shield
- with safety micro-switch
- protection against chips, lubricant and coolant
- easy adaption to the head of the machine
- diameter C of the safety hood should be 150-200 mm larger than the lathe-chuck

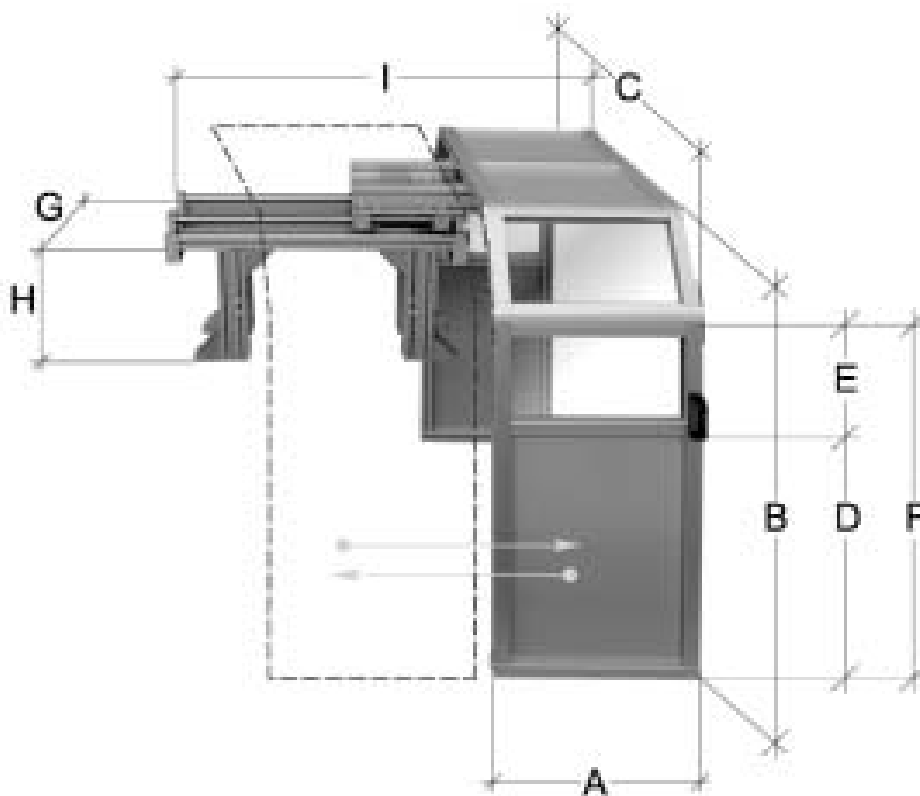

für Futter-Ø / for chuck-Ø	A mm	B mm	C mm	D mm	E mm	F mm	G mm	H mm	I mm	Art.-Nr. / Order no.
800	550	1000	1000	518	282	800	300	390-590	930-1490	<input type="radio"/> ZE-FS22-1000
1200	550	1500	1400	918	282	1200	300	390-590	930-1490	<input checked="" type="radio"/> ZE-FS22-1500

Ausziehbare Spindelabdeckungen Roll up spindle covers

- zweiteilige, ausziehbare Leit- und Zugspindelabdeckung
- 2 Textilbänder bestehend aus kühlmit-
telresistentem und hitzebeständigem
Material
- mit Montageplatte zur Befestigung am
Maschinenbett
- *bipartite roll-up spindle cover*
- *2 protective textile ribbons, heat and
coolant resistant*
- *incl. base plate for fixation on machine*

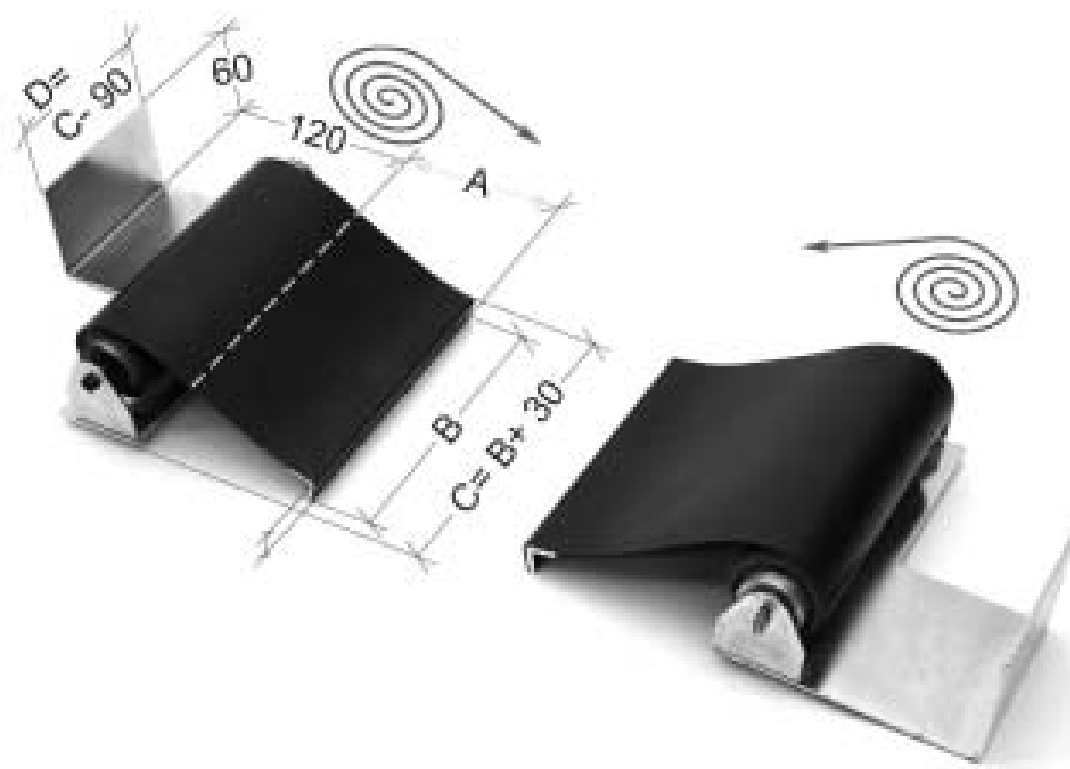

A max mm	B mm	C mm	D mm	Art.-Nr. / Order no.
(2 x) 1200	150	180	90	ZE-RSS-1200
(2 x) 1500	200	230	140	ZE-RSS-1500
(2 x) 2000	200	230	140	ZE-RSS-2000
(2 x) 3000	250	280	190	ZE-RSS-3000

Schutzeinrichtungen für Fräsmaschinen, einstellbar
Safety guards for universal milling machines, adjustable

- mit beweglichen Gelenkarmen
- Schild kann horizontal geöffnet werden
- komplette Schutzeinrichtung kann aus dem Arbeitsbereich geschwungen werden
- mit doppeltem Mikrosicherheits-schalter
- zum Schutz vor Spänen, Spritzwasser und Kühlmittel
- with articulated arms
- shield can be opened horizontally
- entire safety guard can be displaced from workplace for better accessibility
- with double safety microswitch
- protection against chips, lubricant and coolant



Abb. zeigt Befestigung von links
Figure shows mounting from left

2 Ausführungen: Befestigung von rechts oder links - bitte in der Bestellung angeben
2 models: mounting from right or left - please specify in your order

A mm	B mm	Art.-Nr. / Order no.
300	200	ZE-FS30-300
400	235	ZE-FS30-400
500	235	ZE-FS30-500
600	235	ZE-FS30-600

Schutzeinrichtungen für Fräsmaschinen Safety guards for universal milling machines

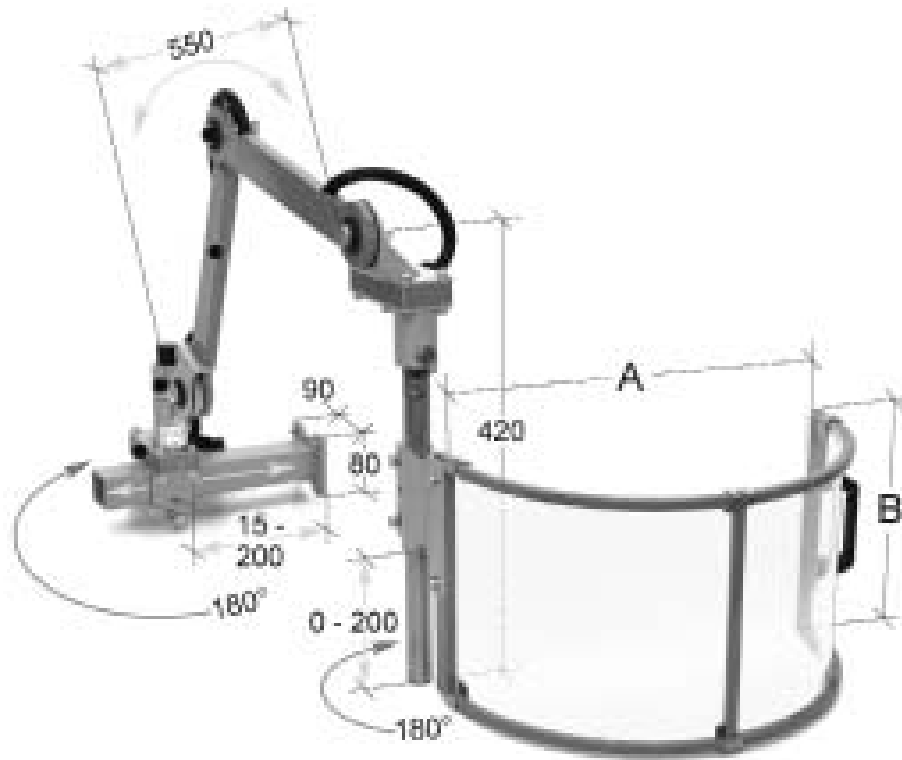
- zum Schutz vor Spänen, Spritzwasser und Kühlmittel
- mit Mikrosicherheitsschalter
- mehrfach verstellbar durch Gelenkarme
- geeignet für häufige Umrüstung
- Acrylglas-Schild 180° nach oben zu öffnen
- komplett aus dem Arbeitsfeld wegschwenkbar
- protection against chips, lubricant and coolant
- with safety micro-switch
- articulated arms for multiple adjustment
- suitable for frequent retooling
- shield made from acrylic glass, vertically foldable (180°) with position locking knob
- completely slewable out of working area



Abb. zeigt Befestigung von links
Figure shows mounting from left

2 Ausführungen: Befestigung von rechts oder links - bitte in der Bestellung angeben
2 models: mounting from right or left - please specify in your order

A mm	B mm	C mm	D mm	Art.-Nr. / Order no.
620	250	170	405	ZE-FS02-620
725	300	200	430	ZE-FS02-725

Schutzeinrichtungen für Ständerbohrmaschinen
Safety guards for drilling machines

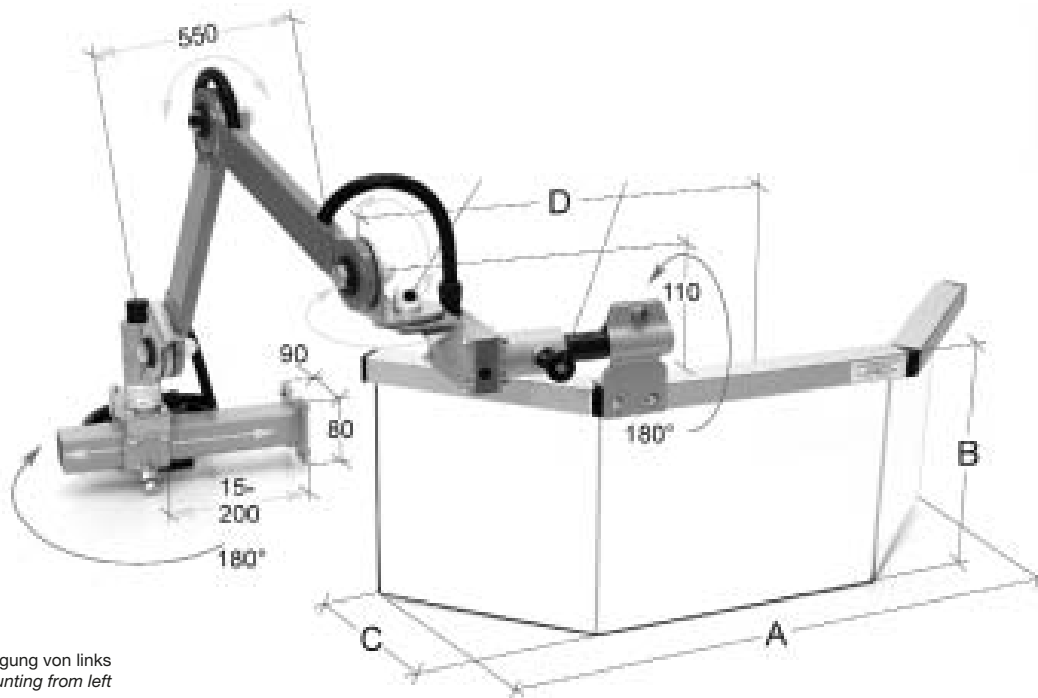
- geeignet für Ständerbohrmaschinen
 - zum Schutz vor Spänen, Spritzwasser und Kühlmittel
 - mit Mikrosicherheitsschalter
 - mit zweifacher (vertikaler) Verstellmöglichkeit
 - Befestigung an der linken Seite der Maschine
 - semi-oktagonales, austauschbares Schutzschild aus Polycarbonat
 - zur Innen- oder Außenbefestigung
- suitable for column drilling machines
 - protection against chips, lubricant and coolant
 - with safety micro-switch
 - adjustable in 2 vertical positions
 - mounting on the left side of the machine
 - semi-octagonal, replaceable shield made from polycarbonate
 - inside or outside mounting

Typ 1 / Type 1

Typ 2 / Type 2

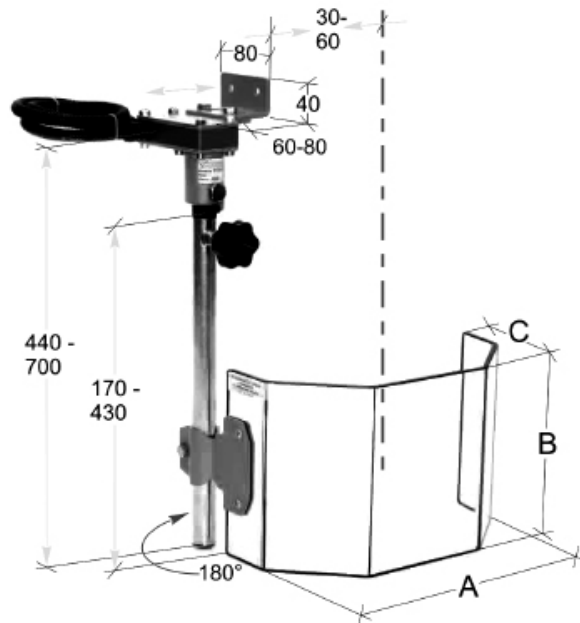
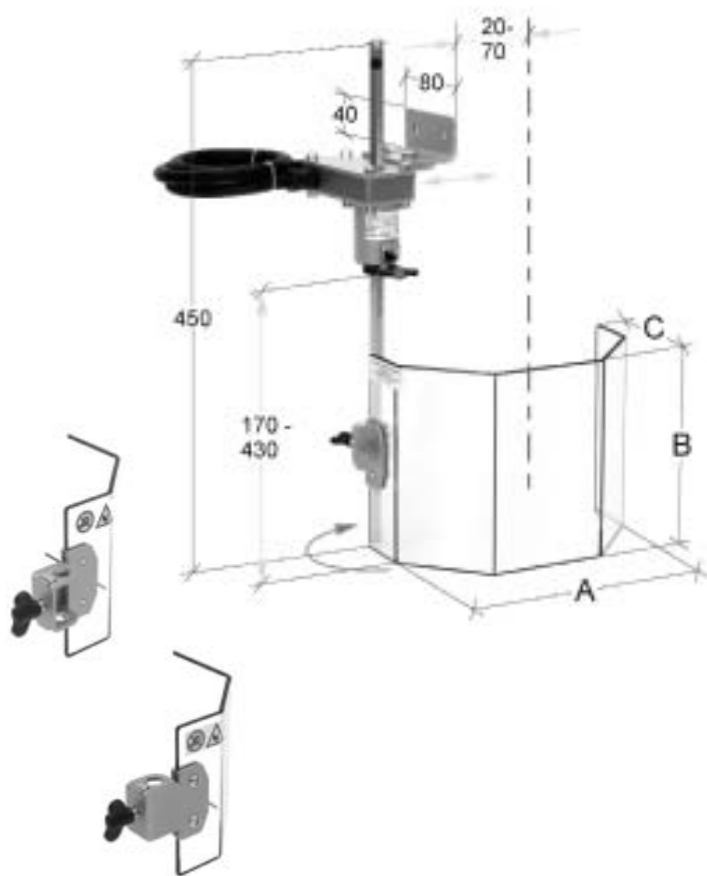

Typ / Type	A mm	B mm	C mm	Art.-Nr. / Order no.
1	230	130	115	● ZE-BS-130
1	230	180	115	● ZE-BS-180
2	300	200	150	● ZE-BS-300

Teleskopabdeckung für Ständerbohrmaschinen
Telescopic safety guard for drilling machines

- vertikal verstellbar
 - Abdeckung öffnet seitlich (180°)
 - mit Mikrosicherheitsschalter
 - zum Schutz vor Spänen, Spritzwasser und Kühlmittel
- vertically adjustable
 - shield opens laterally (180°)
 - with safety micro-switch
 - protection against chips, lubricant and coolant

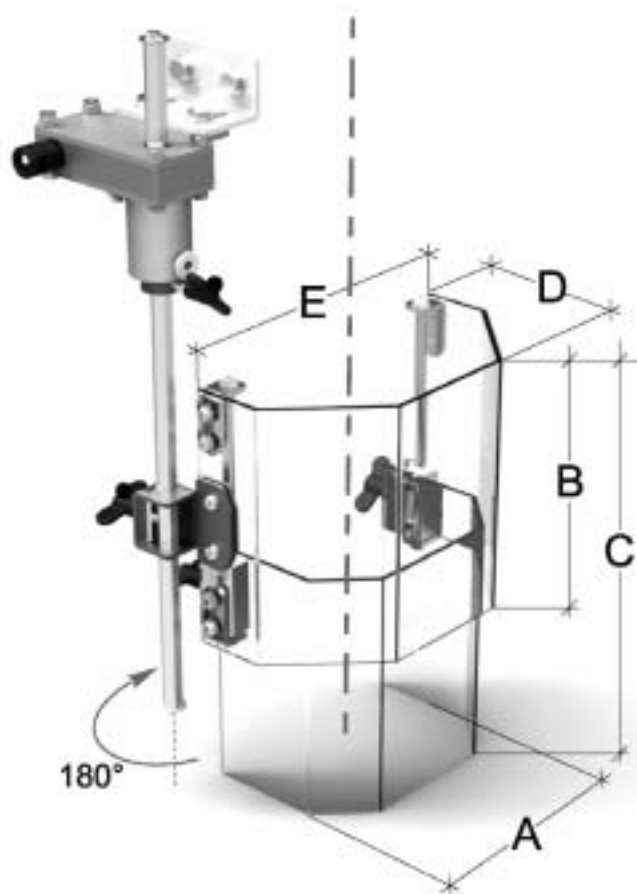

A mm	B mm	C mm	D mm	E mm	Art.-Nr. / Order no.
172	180	180-300	114	230	ZE-TBS05-180

Rundumabdeckungen für Ständerbohrmaschinen
Circumferential protections for drilling machines

- Rundumabdeckung öffnet seitlich
- mit Mikrosicherheitsschalter
- zum Schutz vor Spänen, Spritzwasser und Kühlmittel
- einfache Montage an der linken Seite des Spindelkopfes
- circumferential shield opens laterally
- with safety micro-switch
- protection against chips, lubricant and coolant
- easy adaption to the left side of the machine

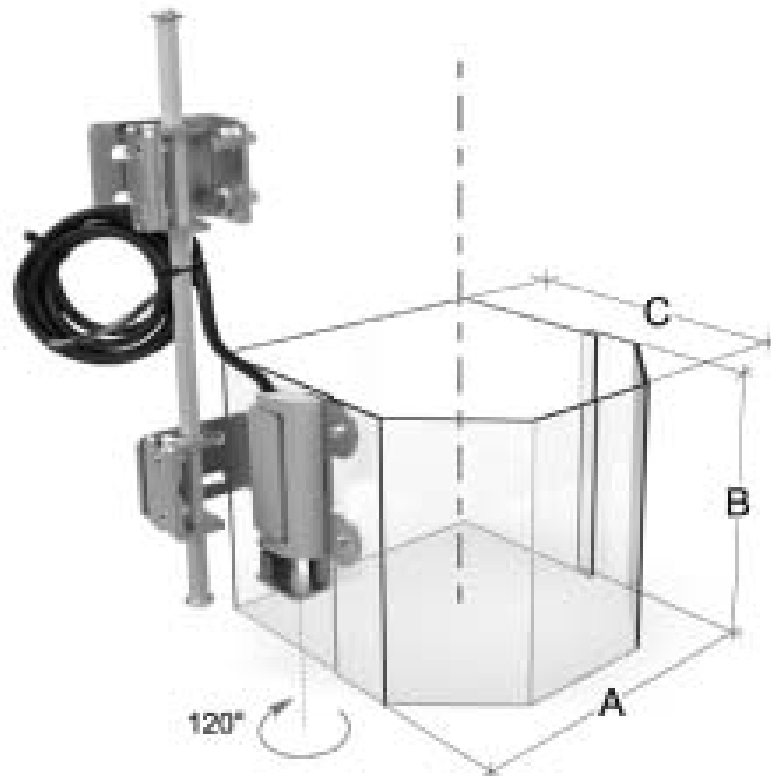

A mm	B mm	C mm	Art.-Nr. / Order no.
220	130	235	ZE-RBS30-130
220	180	235	ZE-RBS30-180

Schutzeinrichtungen Safety guards

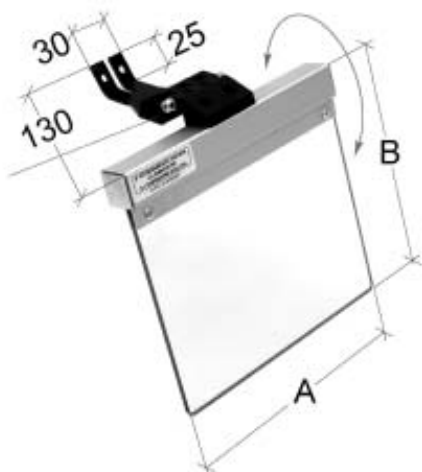

Schutzeinrichtungen für Schleifmaschinen Safety guards for grinding machines

- mit Gelenk zur Schnelleinstellung
- Schild aus Acrylglas
- with articulated joint for rapid adjustment
- shield made from acrylic glass

A mm	B mm	Art.-Nr. / Order no.
160	145	ZE-SMS02-160
200	185	ZE-SMS02-200

Schutzeinrichtung mit 2 Schutzschilden für Schleifmaschinen Safety guard, double-shielded for grinding machines

- mehrfach verstellbar mit zwei aufklappbaren Schilden aus Acrylglas
- zum Schutz vor Spänen, Spritzwasser und Kühlmittel
- mit Mikrosicherheitsschalter
- multiple adjustment with 2 shields made from acrylic glass
- protection against chips, lubricant and coolant
- with safety micro-switch

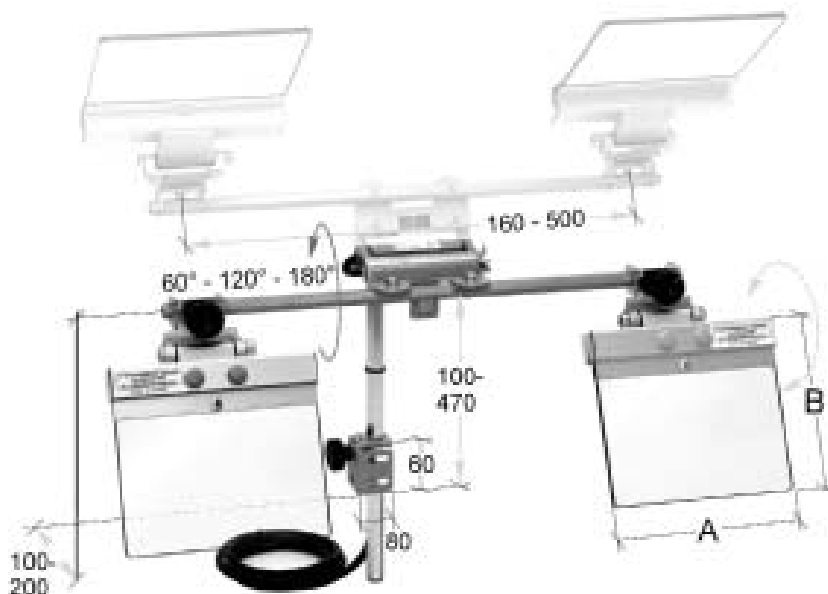

A mm	B mm	Art.-Nr. / Order no.
160	145	ZE-SMS11-160D
200	185	ZE-SMS11-200D



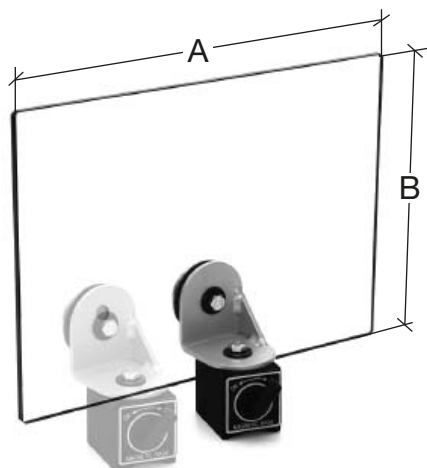

Schutzschilder mit Magnetfuß
Safety guards with magnetic base

- Schutzschild in 2 Positionen justierbar
- Spannkraft 40 kg
- adjustable in 2 positions
- clamping force 40 kg

A mm	B mm	Art.-Nr. / Order no.
350	250	● ZE-MS20-350/250
400	300	● ZE-MS20-400/300

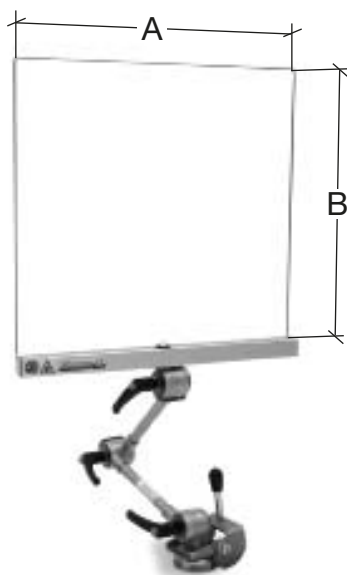

Schutzschilder mit Magnetfuß und Gelenkarm
Safety guards with magnetic base and articulated arm

- frei justierbarer Schild
- vertikal und horizontal einstellbar
- Spannkraft 110 kg
- freely adjustable shield
- vertically and horizontally adjustable
- clamping force 110 kg

A mm	B mm	Art.-Nr. / Order no.
400	400	● ZE-MS30-400/400
400	500	● ZE-MS30-400/500
500	400	● ZE-MS30-500/400



Not-Aus Steuerungseinheiten mit Spannungswarnleuchte Safety switch control with voltage warning light



- Transformator 400/24V-20VA
- Gussgehäuse
- mit Kurzschluss- und Überlastungsschutz
- Sicherheitsrelais mit Reset-Funktion
- Schaltkreise durch zwei Sicherungen abgesichert
- für Maschinen bis max. 4,3 kW
- **bei Bestellung bitte Spannung und Leistungsaufnahme (kW) der Maschine angeben**

- transformer 400/24V-20VA
- die-cast box
- with short circuit and overload protection
- safety thermal relay with automatic reset
- with 2 auxiliary circuit protection fuses
- for machines with 4,3 kW max.
- **in case of order please indicate voltage and power (kW) of the machine**

Abmessungen / Dimensions
mm

Art.-Nr. /
Order no.

192 x 167 x 96

▶ ZE-NA-GE12



- Transformator 400/24V-30VA
- Gussgehäuse
- inkl. Magnetschutzschalter
- mit Kurzschluss- und Überlastungsschutz
- Sicherheitsrelais mit Reset-Funktion
- Schaltkreise durch zwei Sicherungen abgesichert
- **bei Bestellung bitte Spannung und Leistungsaufnahme (kW) der Maschine angeben**

- transformer 400/24V-30VA
- die-cast box
- with magnetothermal safety switch
- with short circuit and overload protection
- safety thermal relay with automatic reset
- with 2 auxiliary circuit protection fuses
- **in case of order please indicate voltage and power (kW) of the machine**

Abmessungen / Dimensions
mm

Art.-Nr. /
Order no.

192 x 167 x 96

▶ ZE-NA-GE10



- Transformator 400/24V-30VA
- Stahlgehäuse
- inkl. Magnetschutzschalter
- Sicherheitstür öffnet nur im unbestromten Zustand
- mit Doppel-Fernsteuerungsknopf
- mit Kurzschluss- und Überlastungsschutz
- mit Sicherheitsrelais
- Schaltkreise durch zwei Sicherungen abgesichert
- **bei Bestellung bitte Spannung und Leistungsaufnahme (kW) der Maschine angeben**

- transformer 400/24V-30VA
- steel box
- with magnetothermal safety switch
- door is opening only in de-energized condition
- with double remote control switch
- with short circuit and overload protection
- with safety relay
- with 2 auxiliary circuit protection fuses
- **in case of order please indicate voltage and power (kW) of the machine**

Abmessungen / Dimensions
mm

Art.-Nr. /
Order no.

254 x 219 x 110

▶ ZE-NA-GE15

Arbeitsleuchten Work lamps

- justierbar durch Gelenkarm
- Befestigung mit Schrauben
- articulated arms for multiple adjustments
- mounted with screws

24V, Schutzgrad IP 65 24V, protection level IP 65



Abbildung / Figure 1

Abbildung / Figure 2

Abbildung / Figure 3

Armlänge / arm length mm	Abbildung / Figure	Art.-Nr. / Order no.
105	1	ZE-LAL-24/105
200 + 200	2	ZE-LAL-24/200
400 + 400	3	ZE-LAL-24/400

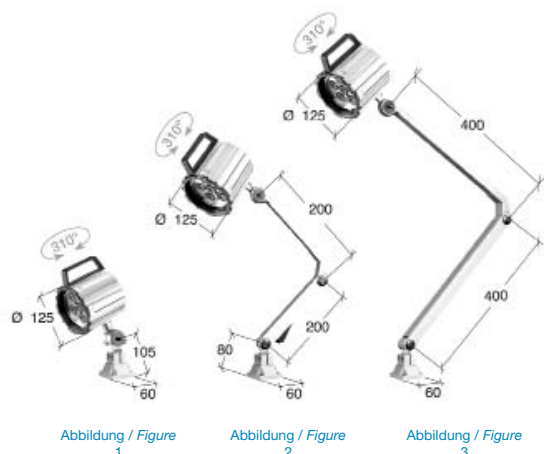
Inkl. Befestigungsschrauben
Incl. fixing screws

100-240V, Schutzgrad IP 65 100-240V, protection level IP 65



Abbildung / Figure 1

Abbildung / Figure 2

Abbildung / Figure 3

Armlänge / arm length mm	Abbildung / Figure	Art.-Nr. / Order no.
120	1	ZE-LAL-230/120
200 + 200	2	ZE-LAL-230/200
400 + 400	3	ZE-LAL-230/400

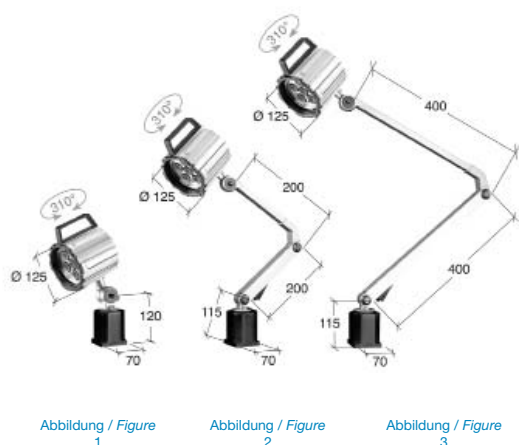
Inkl. Befestigungsschrauben
Incl. fixing screws

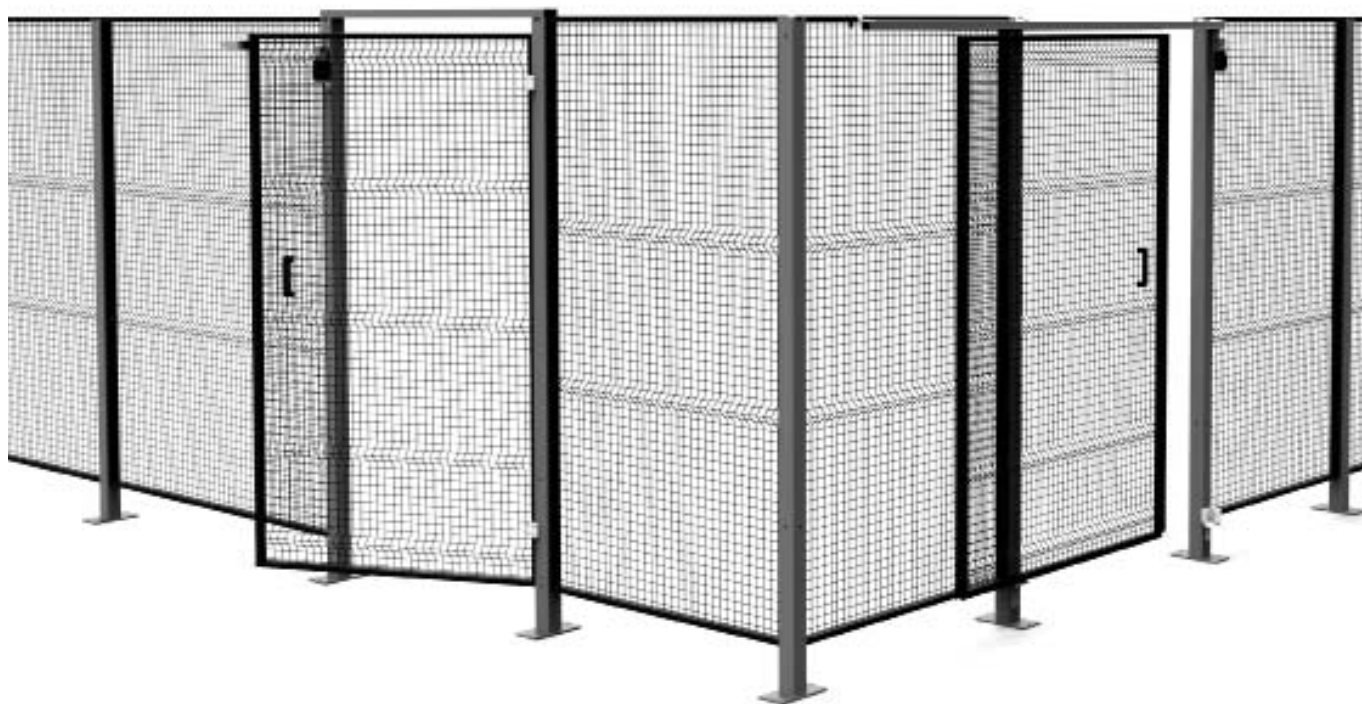

- vielseitig kombinierbare Schutzsysteme (erweiterbar)
 - zur Sicherheit von Personen und Maschinen
 - die Schutzsysteme werden individuell an Ihre Bedürfnisse angepasst
- *modular protective systems*
 - *for the safety of operators and machines*
 - *the system may be adapted individually to your needs*

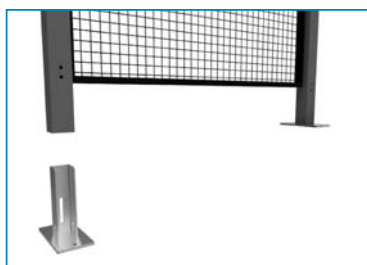

- schnelle und einfache Montage
- *simple and quick assembly*

Schutzzäune Safety panels

- Zäune aus verschiedenen Materialien verfügbar
- different panel materials available

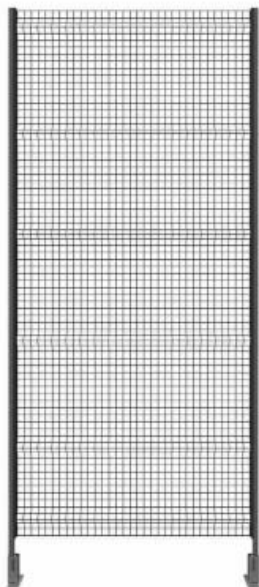

Maschendraht
Mesh wire



Metall
Metal



Kunststoff
Polycarbonat

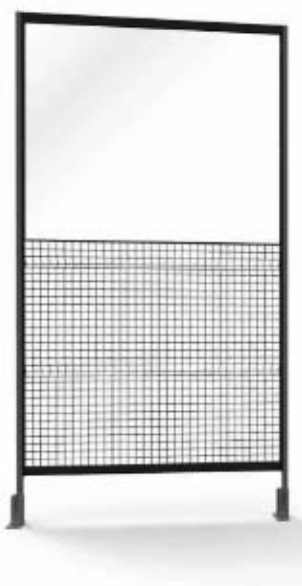

Kunststoff + Maschendraht
Polycarbonat + mesh wire



Kunststoff + Metall
Polycarbonat + metal

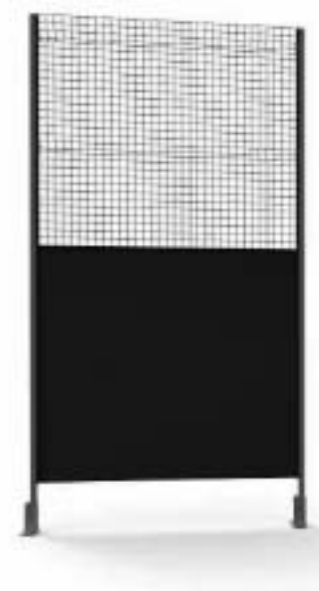

Maschendraht + Metall
Mesh wire + metal

➤ **lieferbar auf Anfrage**

➤ *available upon request*

Schutztüren Safety doors

- Vielzahl an Türen lieferbar

- *great variety of door types available*

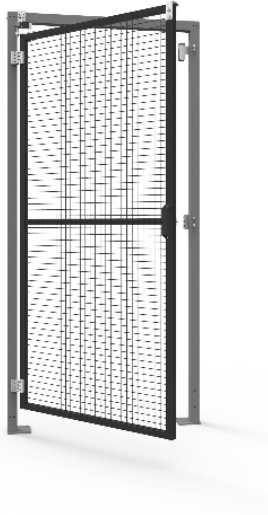

Flügeltür
Leaf door



Schiebetür mit oberer Schiene
Sliding door (upper guide)

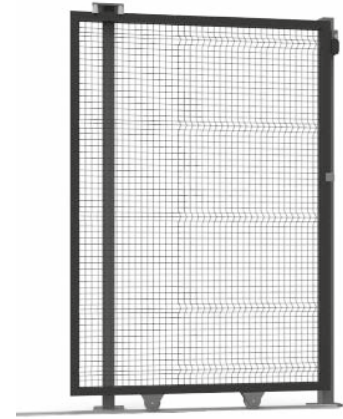

Schiebetür mit Bodenschiene
Sliding door (lower guide)

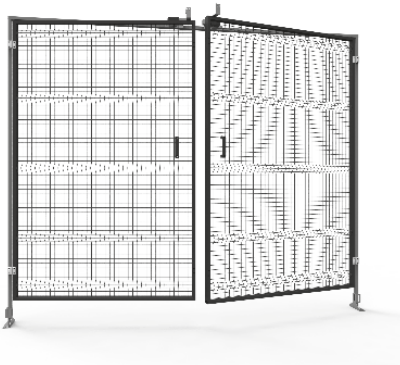

Flügeltür (doppelt)
Double leaf door

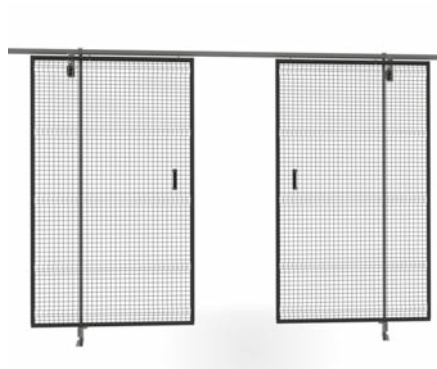

Schiebetür mit oberer Schiene (doppelt)
Double sliding door (upper guide)



Schiebetür mit Bodenschiene (doppelt)
Double sliding door (lower guide)

➤ **lieferbar auf Anfrage**

➤ *available upon request*

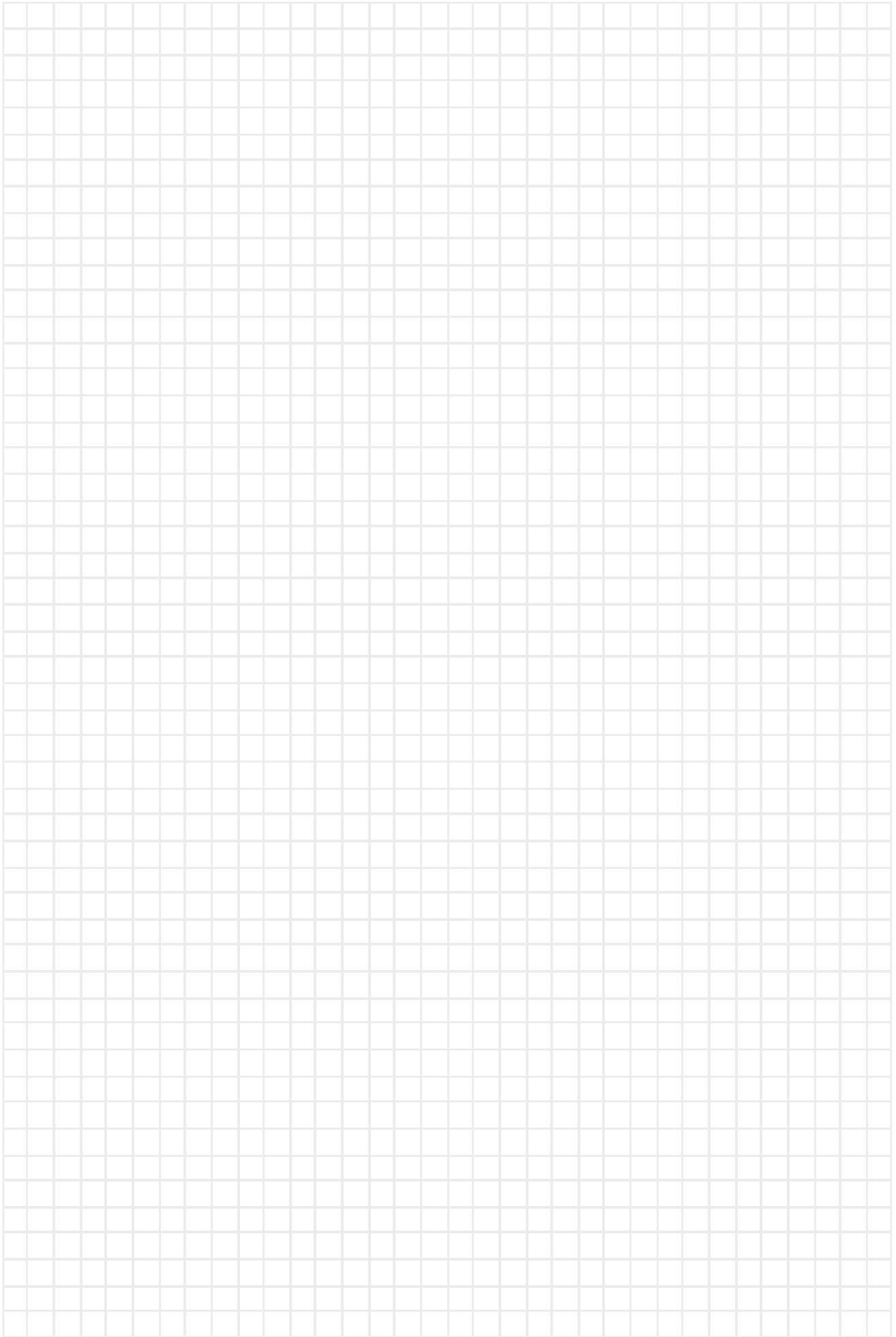

Allgemeine Geschäftsbedingungen

I. Angebot und Vertragsabschluss

1. Für Bestellungen und Lieferungen gelten nachstehende Bedingungen. Sie werden vom Besteller mit Auftragserteilung, spätestens mit der Annahme der ersten Lieferung/Leistung anerkannt und gelten für die gesamte Dauer der Geschäftsverbindung. Telefonischen oder mündlichen Ergänzungen bzw. abweichenden Bedingungen des Bestellers ist widersprochen. Sie sind nur verbindlich sofern sie von uns schriftlich bestätigt wurden.
2. Unsere Angebote sind freibleibend. Aufträge gelten als angenommen, wenn sie von uns schriftlich bestätigt werden. Erfolgt die Lieferung/Leistung unverzüglich ohne Bestätigung, so gilt die Rechnung gleichzeitig als Auftragsbestätigung.
3. Mehr- und Minderlieferungen bei Sonderwerkzeugen bis 10%, mindestens jedoch 1 Stück, sind zulässig. Berechnet wird die jeweilige Lieferung.
4. Alle Angaben über Gewicht, Abmessungen, Leistungen und sonstige technische Daten, die in unseren Unterlagen enthalten sind, sind nur annähernd maßgebend, soweit sie nicht ausdrücklich als verbindlich bezeichnet sind.

II. Lieferung und Preise

1. Wir liefern ab Werk, ausschließlich Verpackungen auf Rechnung und Gefahr des Käufers.
2. Unsere Preise gelten zuzüglich der gesetzlichen Umsatzsteuer.
3. Zugesagte Lieferfristen sind unverbindlich und stehen unter dem Vorbehalt richtiger und rechtzeitiger Selbstbelieferung. Die Lieferfristen verlängern sich angemessen bei Maßnahmen im Rahmen von Arbeitskämpfen, insbesondere Streik und Aussperrung, sowie beim Eintritt unvorhergesehener, unverschuldeter Hindernisse. Die vorbezeichneten Umstände sind auch dann von uns nicht zu vertreten, wenn sie während eines bereits vorliegenden Verzuges entstehen. Beginn und Ende derartiger Hindernisse werden wir in wichtigen Fällen dem Besteller baldmöglichst mitteilen.
4. Der Mindestbestellwert beträgt EUR 40, darunter fallen EUR 10 Mindermengenzuschlag an.

III. Warenrücksendungen und Gutschriften

1. Die Rücksendung von Waren zur Gutschrift ist NUR nach vorheriger Absprache und Genehmigung durch uns möglich.
2. Die Rückgabe der Ware muss in neuwertigem Originalzustand, unbeschädigt und mit vollständigem Zubehör sowie in Originalverpackung erfolgen. Andernfalls kann sie nicht gutgeschrieben werden.
3. Die Wiedereinlagerungsgebühr beträgt grundsätzlich 10% des Warenwerts, mindestens jedoch EUR 10,00. Bei Ersatzbestellung eines gleichwertigen Artikels reduziert sich diese Gebühr auf 5% bzw. EUR 5,00.
4. Die Berechnung höherer Wiedereinlagerungsgebühren aufgrund besonderer Umstände des Falles bzw. des Zustands der zurückgesandten Ware sowie die nachträgliche Ablehnung der Rücknahme nach Prüfung durch uns behalten wir uns jedoch ausdrücklich vor.
5. Artikel, die keine Katalogartikel sind (z.B. Sonderbeschaffungen, Sondermengen und/oder Sonderanfertigungen) können NICHT zurückgegeben werden.
6. Ware, deren Auslieferung länger als 6 Monate zurückliegt, kann NICHT zur Gutschrift zurückgegeben werden.
7. Unfreie Rücksendungen werden nicht angenommen und gehen mit dem Vermerk „Annahme verweigert“ an den Absender zurück.

IV. Zahlung, Zahlungsverzug

1. Die Zahlung ist gemäß den Zahlungsbedingungen zu leisten.
2. Bei verspäteter Zahlung sind Verzugszinsen in Höhe von 8% über dem jeweiligen Basiszinssatz zu entrichten. Zahlungsverzug berechtigt uns zum Rücktritt ohne Fristsetzung. Bei Zahlungsverzug mit einer Rechnung werden unsere sämtlichen Forderungen aus Geschäftsverbindungen mit dem Käufer sofort zahlungsfällig.

V. Bestellung auf Abruf

Bestellungen, die von uns auf Abruf bestätigt werden, müssen – sofern nichts Besonderes vereinbart ist – spätestens innerhalb eines Jahres ab Bestelldatum abgenommen werden.

VI. Eigentumsvorbehalt

1. Die Ware bleibt, ausgenommen der Fall der Weiterveräußerung im ordnungsgemäßen Geschäftsgang, unser Eigentum bis zur vollständigen Bezahlung des Kaufpreises und aller unserer bei Warenlieferung bereits entstandenen Forderungen. Die Forderung des Bestellers aus dem Weiterverkauf unserer unter Eigentumsvorbehalt gelieferten Waren nebst sämtlicher hieraus resultierender Nebenforderungen werden bereits jetzt an uns zur Sicherheit abgetreten. Der Besteller ist ermächtigt, die abgetretenen Forderungen solange einzuziehen, wie er seiner Zahlungspflicht uns gegenüber nachkommt. Bei Verarbeitung der Vorbehaltsware erwerben wir Eigentum an der neuen Sache. Bei Verarbeitung, Vermischung oder Vermengung der Vorbehaltsware mit anderen Gegenständen erwerben wir das Miteigentum entsprechend dem Warenteil.
2. Der Besteller ist verpflichtet, bei Weiterverkauf unter Eigentumsvorbehalt die Kaufpreisforderung gegen den Dritten in einem jederzeit nachprüfbaren Verzeichnis niederzulegen, damit die Forderung als uns zustehend erkennbar ist.
3. Der Eigentumsvorbehalt bleibt auch dann bestehen, wenn unsere Forderungen aus der gelieferten Vorbehaltsware jeweils in ein Kontokorrent eingestellt und der Schlussaldo gezogen und anerkannt wird.
4. Der Besteller verpflichtet sich, die Vorbehaltsware seinerseits unter Eigentumsvorbehalt weiterzuverkaufen.
5. Verpfändung oder Sicherungsübereignung der Vorbehaltsware bzw. der abgetretenen Forderungen sowie Factoring sind unzulässig.
6. Auf unser Verlangen hat der Besteller die Schuldner der abgetretenen Forderungen mitzuteilen, alle zum Einzug erforderlichen Angaben zu machen und die dazugehörigen Unterlagen auszuhändigen. Wir können den Schuldner die Abtretung anzeigen.
7. Von einer Pfändung oder anderer Beeinträchtigung der gelieferten Ware durch Dritte muss uns der Kunde unverzüglich benachrichtigen. Alle uns durch die Pfändung entstehenden Kosten trägt der Kunde.
8. Bei Zahlungsverzug, drohender Zahlungseinstellung, im Falle unbefriedigender Auskunft über Zahlungsfähigkeit bzw. Vermögenslage des Bestellers oder, wenn Zwangsvollstreckungen oder Wechselprozesse gegen ihn vorkommen, sind wir befugt, die gelieferte Ware zurückzunehmen. Der Besteller ist zur Herausgabe verpflichtet. Die Kosten der Rücknahme und der Verwertung der Ware trägt der Besteller.
9. Der Antrag auf Eröffnung des Insolvenzverfahrens berechtigt uns, vom Vertrag zurückzutreten und die sofortige Rückgabe des Liefergegenstandes zu verlangen.

VII. Mängelrüge

1. Erkennbare offensichtliche Mängel können nur unverzüglich schriftlich gerügt werden, spätestens jedoch innerhalb einer Frist von 8 Tagen nach Empfang der Lieferung.
2. Bei begründeter Mängelrüge dürfen Zahlungen nur in angemessenem Verhältnis zum aufgetretenen Mangel zurückbehalten werden.

VIII. Gewährleistung und Haftung

Für Mängel der Lieferung haften wir wie folgt:

1. Alle diejenigen Teile sind nach unserer Wahl unentgeltlich nachzubessern oder zu ersetzen, die innerhalb von 12 Monaten vom Tag des Versandes an gerechnet, infolge eines vor dem Gefahrenübergang liegenden Umstandes, insbesondere wegen fehlerhafter Bauart, schlechter Baustoffe oder mangelhafter Ausführung unbrauchbar geworden sind oder deren Brauchbarkeit erheblich beeinträchtigt wurde. Die Feststellung der Mängel muss uns unverzüglich schriftlich gemeldet werden. Eine Verletzung dieser Rügepflicht enthebt uns von jeder Gewährleistung. Nachbesserungsversuche sind mehrmals zulässig und dürfen nur durch uns vorgenommen werden. Der Kunde hat uns hierzu die erforderliche Zeit und Gelegenheit zu geben, sonst sind wir von der Mängelhaftung befreit. Ersetzte Teile werden unser Eigentum.
2. Bessert der Besteller oder ein Dritter unsachgemäß nach, haften wir nicht für die daraus entstehenden Folgen. Werden vom Kunden oder Dritten ohne unsere Zustimmung Instandsetzungen, Beschädigungen oder Änderungen vorgenommen, die mit dem geltend gemachten Mangel in Verbindung stehen, entfällt unsere Gewährleistungspflicht.
3. Keine Gewähr wird insbesondere in folgenden Fällen übernommen: ungeeignete oder unsachgemäße Verwendung, fehlerhafte Montage bzw. Inbetriebsetzung durch den Besteller oder Dritte, natürliche Abnutzung, fehlerhafte oder nachlässige Behandlung, nicht ordnungsgemäße Wartung, ungeeignete Betriebsmittel, chemische, elektrochemische oder elektrische Einflüsse.
4. Wir sind im Falle unserer Verpflichtung, neu hergestellte Sachen nachzubessern, nur verpflichtet, die zum Zwecke der Nachbesserung erforderlich werdenden Aufwendungen des Bestellers, insbesondere Transport-, Wege- und eventuelle Arbeits- und Materialkosten zu erstatten, nicht aber darüber hinausgehende Schäden, soweit uns nicht grobes Verschulden trifft.
5. Für Mängel des vom Besteller angelieferten Materials haften wir nicht. Bei Fertigung nach Zeichnung des Bestellers haften wir nur für zeichnungsgemäße Ausführung.
6. Für wesentliche Fremderzeugnisse beschränkt sich unsere Haftung auf die Abtretung der Haftungsansprüche, die uns gegen den Lieferer des Fremderzeugnisses zustehen.
7. Weitere Ansprüche des Bestellers, insbesondere ein Anspruch auf Ersatz von Schäden, die nicht an dem Liefergegenstand selbst entstanden sind, sind ausgeschlossen. Dieser Haftungsausschluss gilt nicht bei Vorsatz oder grober Fahrlässigkeit unserer gesetzlichen Vertreter oder leitenden Angestellten.

IX. Haftung für Nebenpflichten, sonstige Haftung

Die in unseren allgemeinen Verkaufsunterlagen, in Vorschlägen, Projektierungen usw. enthaltenen anwendungstechnischen Angaben befreien den Kunden nicht von seiner Verpflichtung, sich durch eigene Prüfung von der Eignung unserer Produkte für den von ihm beabsichtigten Zweck zu überzeugen. Haftungsansprüche aus schuldhafter Verletzung der uns obliegenden Nebenpflichten sind in jedem Falle ausgeschlossen, soweit nicht grobe Fahrlässigkeit oder Vorsatz unserer gesetzlichen Vertreter oder leitenden Angestellten vorliegt. Gegebenenfalls beschränkt sich diese auf höchstens 5 % vom Wert der betreffenden Lieferung bzw. Leistung.

X. Recht des Lieferers auf Rücktritt

Ist die Durchführung eines Auftrages, der aufgrund eines Entwurfes oder einer Zeichnung des Bestellers ausgeführt werden soll, wegen fehlenden technischen oder technologischen Voraussetzungen, unmöglich (z.B. Konstruktionsmangel), so steht uns das Recht zu, ganz oder teilweise vom Vertrag zurückzutreten. Schadenersatzansprüche des Bestellers wegen eines solchen Rücktritts bestehen nicht.

XI. Schutzrechte

1. Für alle in unseren Unterlagen enthaltenen oder in unseren Angeboten beigefügten Abbildungen, Skizzen, Zeichnungen behalten wir uns Eigentums- und Urheberrechte vor. Jegliche Verwendung, Zugänglichmachung, Nachahmung oder Vervielfältigung ist ohne unsere ausdrückliche Genehmigung verboten.
2. Der Besteller übernimmt für die von ihm beizubringenden Unterlagen, Pläne, Muster oder dgl. die alleinige Verantwortung. Der Besteller hat dafür einzustehen, dass von ihm vorgelegte Ausführungszeichnungen in Schutzrechte Dritter, nicht eingreifen. Wir sind dem Besteller gegenüber nicht zur Prüfung verpflichtet, ob durch Abgabe von Angeboten, die aufgrund der vom Besteller vorgelegten Ausführungszeichnungen erstellt worden sind, irgendwelche Schutzrechte Dritter verletzt werden, es sei denn, es trifft uns bzw. einen leitenden Angestellten Vorsatz oder grobes Verschulden. Sollten wir von Dritten in Anspruch genommen werden, so hat uns der Besteller freizustellen und uns schadlos zu halten.
3. Betriebsmittel, die zur Herstellung der Vertragsgegenstände angefertigt werden, bleiben unser Eigentum und werden nicht ausgeliefert, auch wenn sie ganz oder teilweise berechnet werden.

XII. Erfüllungsort und Gerichtsstand

1. Gerichtsstand ist das für den Sitz des Lieferers zuständige Gericht. Der Lieferer ist jedoch berechtigt, am Hauptsitz des Bestellers Klage zu erheben.
2. Für die vertraglichen Beziehungen gilt ausschließlich das Recht des Landes in welchem der Verkäufer seinen Sitz hat.

XIII. Sonstiges

1. Dem Besteller erklären wir ausdrücklich unsere Bereitschaft, mit uns inhaltlich andere Vertragsbedingungen auszuhandeln als wir sie in den vorstehenden AGB festgelegt haben. Unwirksamkeit einzelner Vertragspunkte berührt den Bestand des übrigen Vertrages nicht. Ist eine Regelung unwirksam, so gilt das gesetzlich Zulässige.
2. Wir speichern Daten des Kunden im Rahmen der Geschäftsbeziehung mittels elektronischer Datenverarbeitung. Unsere Datenschutzerklärung finden Sie auf unserer Website.

© 2021

Terms and conditions

I. Quotation, Conclusion of Contract

1. The present Terms and Conditions shall apply exclusively for all our supplies and deliveries. They are considered accepted by the Purchaser once he accepts the first delivery and shall be valid for the entire duration of business relation. Any amendments by the Purchaser – verbal or by phone – shall not be accepted. They shall only be binding if confirmed by us in writing.
2. Our quotations shall always be subject to change without notice. Orders shall be considered accepted if confirmed by us in writing. If any delivery/service is provided immediately without any confirmation, the invoice shall also be deemed to be the order confirmation.
3. Excess or short deliveries of up to 10 % of the order quantity (at least 1 off) are acceptable for special tools made to the customer's specification. The respective delivery shall be invoiced.
4. All details like weight, dimensions, performance and other technical parameters shall be considered approximative unless they are explicitly defined as binding.

II. Delivery and Pricing

1. Our deliveries are made on an "ex works" basis at the Purchaser's risk and expense.
2. Prices are understood plus the statutory Value Added Tax.
3. Delivery dates confirmed by us shall not be binding but subject to a correct and punctual supply to ourselves. Delivery periods shall be prolonged adequately in case of labour disputes, strikes, lockouts and by other unforeseeable events beyond our control. We shall not be held responsible for the aforementioned events even if they occur within an existing delay. The Purchaser shall be informed on the beginning and end of such event.
4. The minimum order value amounts to Euro 40,00. The markup for small-volume purchases below Euro 40,00 is Euro 10.

III. Return of goods and credit notes

1. Goods must ONLY be returned for credit after prior approval by the seller.
2. Any goods returned must be in original packing, undamaged and with full accessories included. Otherwise no credit note can be issued.
3. A restorage fee of 10% of the order value shall be charged, however, a minimum of Euro 10,00. If an order is placed in return, we will charge 5% or Euro 5,00 resp.
4. We expressly reserve the right to charge higher restorage fees under certain circumstances e.g. a poor state of returned goods or to subsequently refuse acceptance at all.
5. Items beyond the standard range of our catalogue (e.g. special goods or quantities and/or special productions) MUST NOT be returned at all.
6. Goods bought more than 6 months ago must not be sent back.
7. Goods returned to us carriage forward, shall not be accepted and returned at the Purchaser's expense.

IV. Payment, Default of Payment

1. Payments shall have to be made according to the terms set forth on the relevant invoice.
2. For delayed payments we will charge default interest in the amount of 8% above the relative base rate. Default of payment entitles us to a cancellation of the contract without prior notice. If payment of one invoice is delayed all other payments resulting from the business relationship shall become due immediately.

V. Make-and-Hold-Orders

Orders confirmed by us on a make-and-hold-basis have to be called off within one year after the date of order at the latest.

VI. Retention of Title

1. All goods delivered shall remain our property until full payment of the purchase price (incl. all related claims incurred with shipment of the goods) has been effected. Any claims of the Purchaser resulting from a resale of our goods – delivered under retention of title – shall be deemed to be ceded to us as security. The Purchaser is allowed to collect receivables for the ceded claims as long as he fulfills his payment obligations with the seller. If title retention goods are processed, we acquire property of the new product. In case of any processing, commingling or mixture of our title retention goods with other products, we acquire a co-ownership according to the share of our product.
2. In case of any resale of title retention goods by the Purchaser, the latter shall be obliged to provide all information necessary to collect payment.
3. Any retention of title shall persist even if our claims are forming part of a current account, a final balance has been determined and acknowledges.
4. The Purchaser shall be obliged to resell our goods with a retention-of-title-clause, too.
5. Pledging or security transfer of our title retained goods and/or ceded claims as well as factoring are impermissible.
6. Upon our instigation the Purchaser shall have to inform all debtors of any ceded claims, provide all information required for collection and submit the corresponding documents.
7. Prior to any seizure of the goods delivered or any other impairment whatsoever by a third party, the seller has to be informed. Any costs entailed by such seizure of pledge shall have to be borne by the customer.
8. We are entitled to withdraw delivered goods in case of any late payments, payment stops, insufficient information about the Purchaser's liquidity or his financial status, pending compulsory executions or procedures based on claims arising out of bills of exchange. The Purchaser is obliged to hand over the delivered goods. Any costs incurred shall have to be borne by the Purchaser.
9. Any petition in insolvency proceedings shall entitle us to resign from the contract and insist on a return of the delivered object.

VII. Claims

1. Obvious quality flaws or defects shall have to be announced in writing immediately, however, no later than 8 days after receipt of the goods.
2. In case of any justified complaints, payments shall only be reduced in reasonable proportion to the defect incurred.

VIII. Warranty and Liabilities

We are liable for the following defects in quality:

1. All parts or services will be remedied, at our discretion, free of charge or redelivered or provided again, that are found to feature a quality defect during the statutory period of limitation – irrespective of service life – providing the origin thereof already existed at the time

of passing of risk. Claims to quality defects will become statute-barred in 12 (twelve) months. The period of time commences with the passing of risk. We shall have to be informed immediately in writing if the material sold by us is found to be defective. Failure to do so shall release us from any warranty obligation. We have the right to remedy defects which must be carried out by ourselves or qualified personnel entrusted by us. The Purchaser shall have to grant us sufficient time for remedial action. Replaced items become our property.

2. If the Purchaser or any third party carries out said remedial action, we shall not be held responsible for any consequences. If goods are remedied, repaired or modified by the Purchaser or a third party without prior approval by us, we shall be released from any warranty claims.
3. Warranty claims shall not be accepted in case of inappropriate use, faulty assembly and/or putting into operation by the Purchaser or a third party, normal wear, misuse or improper handling, insufficient maintenance, chemical, electro-chemical or electrical influences.
4. Our obligation to remedy delivered items shall only cover transport, material and labour costs. Unless in cases of gross negligence, we shall not be liable for any further costs incurred.
5. We shall not be liable for defects of material supplied by the Purchaser. If manufacture is carried out according to the Purchaser's drawing, we shall only be responsible for an execution according to said drawing.
6. For essential third-party products our liability shall be limited to the liability claim towards the supplier of the aforementioned third-party product.
7. Further claims of the Purchaser – in particular with regard to indemnification of damage, not having occurred to the delivered object itself – shall be excluded. Such disclaimer shall of course not be applicable in cases of gross negligence of our legal representative or senior executives.

IX. Overall Liabilities

Any application-related information provided in our general sales catalogue, project documents etc. shall not release the Purchaser from his obligation to convince himself of the adequacy and suitability of our products for the intended use. Any liability claims based on culpable infringement of other collateral duties shall be excluded in any case, unless attributable to gross negligence or willful intent of our legal representatives or leading staff. Where applicable, such liability shall be limited to a maximum of 5 % of the pertinent order value.

X. Supplier's Right of Withdrawal from the Contract

If the performance of an order that is based on the Purchaser's draft or drawing turns out to be not feasible for any reason (e.g. missing technical or technological design requirements), we shall be entitled to withdraw – fully or in part – from the contract. No claims for damages shall be accepted by the Purchaser resulting from such withdrawal.

XI. Trade mark rights

1. For all sketches, drawings, photographs and other illustrations contained in our documents and quotations we reserve both property and copy rights. Any reproduction, duplication, disclosure to third parties shall be prohibited unless expressly authorized by us.
2. The Purchaser shall assume sole responsibility for all kinds of document, plans, samples or the like to be submitted. Moreover, he shall assure that said documents will not infringe on any property rights of third parties. We cannot be held responsible for any execution drawings submitted by the Purchaser that are affecting any property or trade mark rights unless a deliberate act or gross negligence becomes evident by us or a member of the leading management. If any claims should be asserted by third parties, the Purchaser shall have to indemnify and hold us harmless.
3. Production facilities manufactured for the purpose of fabrication of the subject-matter of the contract, shall not be delivered but remain our property even if invoiced fully or in part.

XII. Place of jurisdiction and payment

1. Place of performance and jurisdiction shall be the registered office of the relevant seller. We are, however, entitled to file a suit at the Purchaser's headquarters.
2. Contractual relationships shall be governed by the laws of the seller's headquarters.

XIII. Miscellaneous

1. We expressly declare our willingness to negotiate contractual terms other than those set forth in the present "General Terms and Conditions". The ineffectiveness of individual contract terms, however, shall not affect the validity of the remaining ones. Should one term prove to be ineffective, it shall be replaced by its legal equivalent.
2. Purchaser's data shall be stored within the frame of regular data processing on the basis of the existing business relations. You can find our data protection declaration on our website.

© 2021



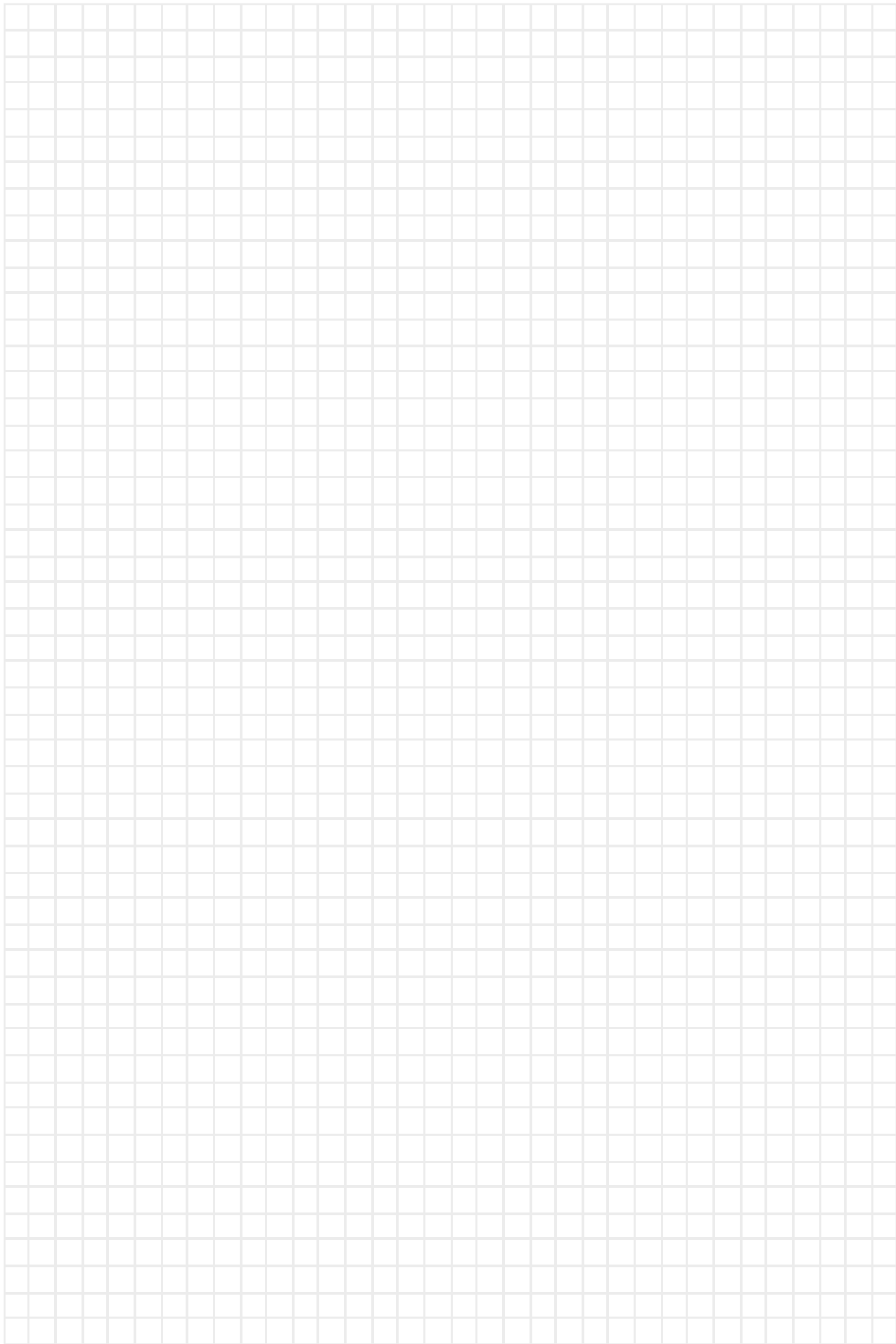

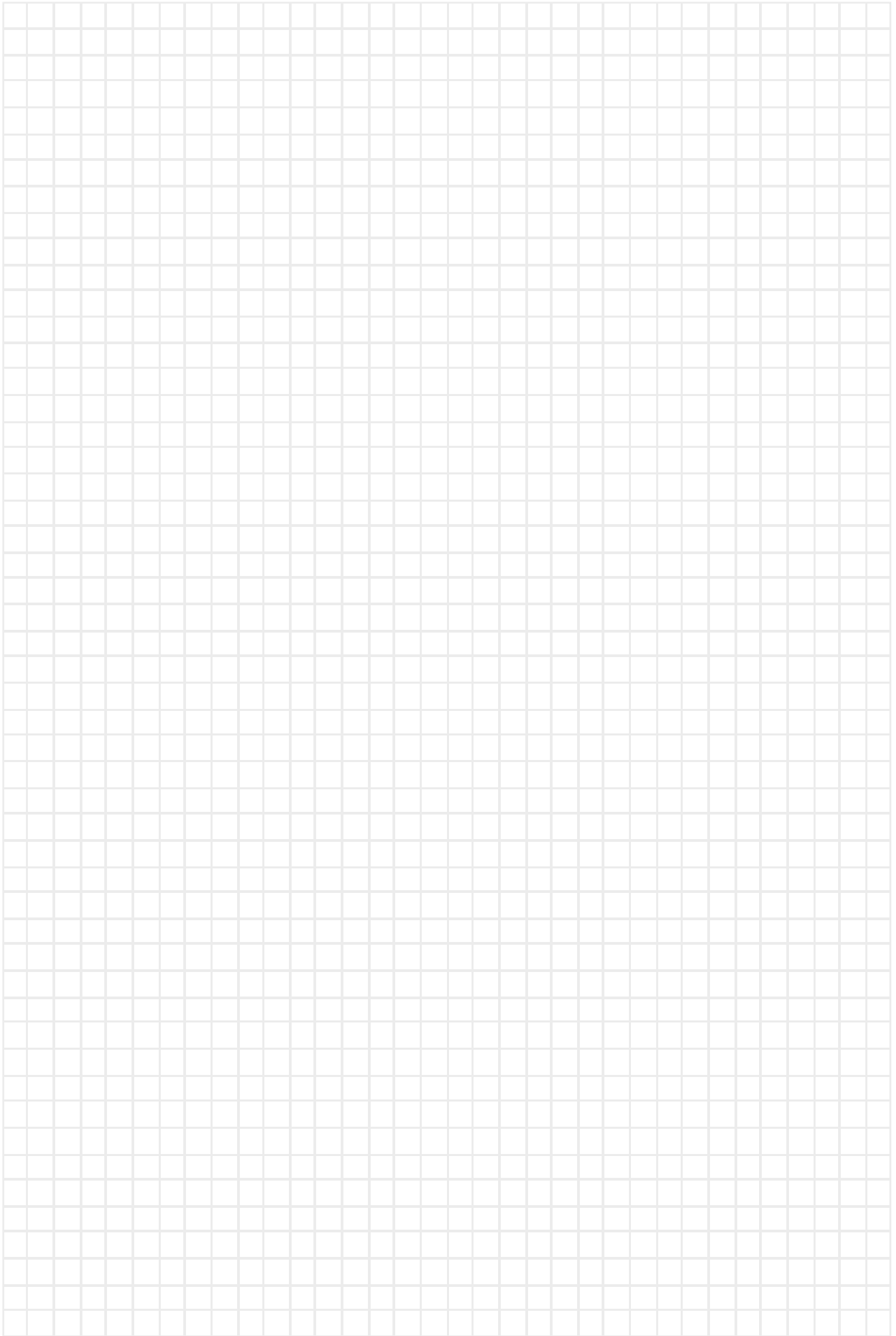

Stichwortverzeichnis

A			
Abdrückmuttern	123	Drehfutter stationär.....	82-84
Abstechhalter VDI.....	166,167	Drehfutteranschlag	48
Alukoffer.....	204/216	Drehplatten für Schraubstöcke.....	137,146
angetriebene Werkzeuge DIN 5480.....	182/183	E	
angetriebene Werkzeuge DIN 5482.....	184/185	Einlegeprismen	209
angetriebene Werkzeuge TOEM.....	186	Einrichtehalter VDI	178
Anzugsbolzen DIN 69872	245	Einstellringe.....	283
Anzugsbolzen ISO 7388.....	245	Endmaßsatz.....	280
Anzugsbolzen MAS-BT.....	246	Erodierschraubstöcke	155-157
Anzugsbolzen Ott.....	247	F	
Anzugsbolzen S20 x 2.....	246	Flansche DIN 55026.....	40,41,61
Aufsatzbacken, hart f. Keilstangenfutter	31	Flansche DIN 55027	40,42
Aufsatzbacken, hart f. Kraftspannfutter.....	64	Flansche DIN 55029.....	41,42
Aufsatzbacken, hart f. Planspiralfutter.....	24	Flansche für Rundtische	78,80
Aufsatzbacken, weich f. Keilstangenfutter	31	Flansche MK.....	43,125
Aufsatzbacken, weich f. Kraftspannfutter	64	Fräsdorne f. Aufschraubfräser	227,228,234,242
Aufsatzbacken, weich f. Planspiralfutter	25	Fräsdornringe	261,262
Aufspannsets.....	287	Fräseranzugsschrauben.....	264
Aufspannwinkel	94,95	Fräsersätze	287
Aufspannwürfel.....	96	Fühlhebelmessgeräte	277
Aufsteckreibahlen-Halter.....	217	G	
Ausdrehköpfe	250	Gelenkstativ mechanisch	278
Austreiber.....	267	Gewindebohrer-Spannhülsen	102,103
Austreiblappen.....	264	Gewindebohrzangen	194-196
B		Gewindelehrdorne	284
Backen-Ausdrehringe	46-48,66	Gewindelehrringe	285
Bohrbacken	23	Gewindeschneid-Apparate.....	256
Bohrfutter, NC.....	222,227,233,241	Gewindeschneid-Einsätze	253
Bohrfutter, Schnellspann-	108	Gewindeschneid-Schnellwechselfutter	251,252
Bohrfutteraufnahmen	220,225,231	Grenzlehndorne.....	282
Bohrmaschinen-schraubstöcke.....	150	Grundbacken f. Keilstangenfutter.....	31
Bohrstangen	209	Grundbacken f. Planspiralfutter.....	24
Bohrstangenhalter VDI (E2).....	168	H	
Bohrstangenhalter VDI, Doppel-.....	170	Hochdruckspanner, mechanisch.....	142
Bohrstangenhalter VDI, geschlitzt	169	Hohlspindelanschläge.....	258
C		Hydraulikzylinder	62
Camlockbolzen, DIN 55029.....	27	I	
D		Innen-Messschraubensätze.....	278
Dichtungssätze für Hydraulikzylinder	62	K	
Direktspannzangen MK.....	198	Kantentaster, elektronisch.....	275
Doppelspanner	138	Kantentaster, mechanisch.....	275
Drehbacken f. Planspiralfutter.....	23	Kegeldorne	104,105
		Kegelhülsen	106,131

Kegelwischer	260	Nutensteine.....	259
Keilstangenfutter	30	Nutensteine f. Kraftspannfutter.....	65
Klauenkästen	89	O	
Klemmhülsen.....	101	O-Ringe.....	180
Kombi-Fräseraufsteckdorne.....	218,219,223,230,240	P	
Körnerspitzen, Einsätze	118-120	Parallelunterlagen.....	279
Körnerspitzen, fest	128	Passfedern.....	266
Körnerspitzen, mitlaufend	114-121,126,127	Pendelhalter.....	238
Körnerspitzen, mitlaufend VDI	173	Pendelhalter VDI.....	174
Kraftspannfutter, 2/3-Backen	51	Planscheiben DIN 55026.....	36
Kraftspannfutter, 2-Backen	50	Planscheiben DIN 55027.....	37
Kraftspannfutter, 3-Backen.....	52-56,59,60	Planscheiben DIN 55029.....	38
Kraftspannfutter, 4-Backen.....	57,58	Planscheiben zylindrisch.....	35
Kreuztische	90-92	Planspiralen	26
Kreuztische angetrieben	93	Planspiralfutter, 2-Backen.....	12
Kugelspritzdüsen.....	179	Planspiralfutter, 3-Backen.....	13-16,20,22,28
Kühlmittelröhrchen	244/267	Planspiralfutter, 4-Backen.....	17,18,28
Kurzbohrfutter DIN 2080	109	Planspiralfutter, 6-Backen.....	21,29
Kurzbohrfutter DIN 69871	109,111	Pneumatikspanner	139
Kurzbohrfutter HSK.....	110,111	Prismenblöcke.....	85,86
Kurzbohrfutter MAS-BT	109,111	Prismenblöcke magnetisch.....	85
Kurzbohrfutter MK.....	110	Prüfdorne	242,272,273
Kurzbohrfutter Polygonal	110	Prüfdorne VDI	178,273
Kurzbohrfutter VDI.....	110,173	Prüfstift-Sätze.....	281
L		R	
Leuchten.....	306	Rasterwürfel.....	96
M		Räumstempel	175-177
Magnetspannplatten	88	Räumwerkzeughalter MK.....	219
Maschinenschraubstock, hydraulisch.....	145,147	Räumwerkzeughalter VDI.....	174
Maschinenschraubstock, mechanisch.....	148	Räumwerkzeughalter zyl.....	239
Mehrbereichs-Spannzangen.....	256	Reduzierbuchsen f. Fräseraufnahmen	238
Mehrfach-Spanner	140	Reduzierbuchsen, geschlitzt VDI.....	179
Messerkopfaufnahmen	219,223,230,241	Reduzierbuchsen, Hydrodehn-.....	99
Messuhren	276,277	Reduzierbuchsen, ungeschlitzt VDI.....	179
Mitnehmerbolzen.....	130	Reduzierhülsen MK	98
Mitnehmerringe	265	Reitstöcke.....	77,78
MK-Hülsen.....	209,220,221,225,232,241	Ritzel	26
Monoblockbacken f. Keilstangenfutter	31	Rohlinge.....	222,227,233,242
Monoblockbacken f. Planspiralfutter.....	25,29	Rohlinge VDI	162,163
Monoblockbacken f. Wescott-Futter.....	32,33	Rundtische.....	74,79,80
Montageblöcke.....	269	S	
Morsekegelaufnahmen VDI (F).....	171	Sägeblattaufnahmen	238
N		Schleifbänder.....	213
Notaus-Boxen	305	Schleifbandhalter.....	213
Notfallspannzangen.....	199	Schleifschraubstöcke.....	153,154
Nulleinsteller.....	274		

Schlüssel ER.....	263	Spannzangenfutter, pneumatisch.....	67,68
Schlüssel Fräseranzugsschrauben.....	263	Spannzangensätze.....	202,203
Schlüssel für Anzugsbolzen.....	247	Spannzangenfutter 5C.....	69,70
Schlüssel für Drehfutter.....	27	Spindelhülsen.....	100
Schlüssel für Kühlmittelröhrchen.....	244	Stangengreifer VDI.....	172
Schlüssel OZ.....	263	Stehbolzen DIN 55027.....	26
Schnellwechselstahlhalter Basic.....	210,211	Stirnmitnehmer.....	130
Schnellwechselstahlhalter Ersatzteile.....	212	Synchron-Gewindeschneidfutter.....	254,255
Schnellwechselstahlhalter Multisuisse.....	207-209		
Schraubböcke.....	87	T	
Schrauben für Grundbacken.....	27	Teilapparate.....	74-76,79
Schrauben Weldon.....	266	Teilscheiben für Rundtische.....	77,80
Schraubquerkeile.....	267	Teleskophalter für Schraubstöcke.....	151
Schraubstockbacken.....	137,141,143,144,146,160		
Schraubstöcke Carminati.....	158,159	U	
Schraubstöcke CMC.....	134,136	Überwurfmutter ER.....	265
Schraubstöcke DZM.....	138	Überwurfmutter OZ.....	264
Schraubstöcke Ersatzteile.....	146	Umkehrbacken f. Keilstangenfutter.....	30
Schraubstöcke SVC.....	135	Umkehrbacken f. Wescott-Futter.....	32,33
Schraubstöcke, 3-Achsen.....	149		
Schrumpffutter.....	229,235,243	V	
Schutzabdeckungen.....	297,300-302	Verlängerungshülsen MK.....	98,99
Schutzhauben.....	290-296		
Schutzschilder.....	298,299,303,304	W	
Schutzstopfen VDI.....	180	Weldon-Futter.....	218,220,224,225,231,240
Segmentbacken f. Kraftspannfutter.....	65	Weldonfutter mit Kühlmittelring.....	222,226,233
Sicherheitsmitnehmer.....	258	Wendepplatten-Bohrerhalter VDI (E1).....	167
Spannzangen Erickson.....	197	Wendeschnidplatten.....	250
Spannköpfe.....	200,201	Werkbankschraubstöcke.....	151
Spannkraftmesser.....	285,286	Werkstückanschläge für Schraubstock.....	259
Spanntische.....	80,81	Werkstückanschläge VDI.....	178
Spannzangen 161E.....	199	Werkstückanschläge, universell.....	160,259
Spannzangen 163E.....	199	Werkzeughalter axial VDI (C1-C4).....	165,166
Spannzangen 173E.....	199	Werkzeughalter für Mori Seiki.....	187
Spannzangen 185E.....	199	Werkzeughalter für Nakamura.....	188
Spannzangen 193E.....	199	Werkzeughalter radial VDI (B1-B8).....	163-165
Spannzangen 369E.....	198	Werkzeughalter vierkant VDI (D1-D2).....	166
Spannzangen 385E.....	198	Werkzeugregale.....	268
Spannzangen 574E.....	198	Werkzeugsätze.....	216
Spannzangen 575E.....	198	Werkzeugwagen.....	268
Spannzangen ER.....	191	Wescott-Drehfutter.....	32,33
Spannzangen ER, abgedichtet.....	193		
Spannzangen ER, Klasse I.....	192	Z	
Spannzangen OZ.....	190	Zentrierdorne.....	78
Spannzangenanschläge.....	203	Zentrierkegel, fest.....	43,123,124
Spannzangenfutter.....	218,221,226,232,236,237,240	Zentrierkegel, mitlaufend.....	43,120-122,124,127
Spannzangenfutter VDI.....	169	Zentrierkegelköpfe.....	124
Spannzangenfutter, hydraulisch.....	67	Zentrischspanner.....	152,153
Spannzangenfutter, manuell.....	68,71		

Keyword index

A

adaptor plates DIN 55026 40,41,61
adaptor plates DIN 55027 40,42
adaptor plates DIN 55029 41,42
adaptor plates for round tables 78,80
adaptor plates MT 43,125
aluminium cases 204/216
angle plates 80,81
angle plates 94,95
assembly blocks 269

B

ball spray nozzle 179
bar puller VDI 172
base jaws f. lathe chucks 24
base jaws f. wedge bar chucks 31
blanks 222,227,233,242
blanks VDI 162,163
boring bar holder VDI (E2) 168
boring bar holder VDI, double 170
boring bar holder VDI, slotted 169
boring bars 209
boring heads 250
box jaws 89
broaching cutters 175-177
broaching toolholders cyl. 239
broaching toolholders MT 219
broaching toolholders VDI 174

C

centers, fixed 128
centers, inserts 118-120
centers, revolving 114-121,126,127
centers, revolving VDI 173
centrifugation arbors 78
clamping cubes 96
clamping force meter 285,286
clamping heads 200,201
clamping nuts ER 265
clamping nuts OZ 264
clamping sets 287
clamping sleeves 101
clutch drive rings 265
collet chucks 218,221,226,232,236,237,240
collet chucks 5C 69,70
collet chucks VDI 169

collet chucks, hydraulic 67
collet chucks, manual 68,71
collet chucks, pneumatic 67,68
collets 161E 199
collets 163E 199
collets 173E 199
collets 185E 199
collets 193E 199
collets 369E 198
collets 385E 198
collets 574E 198
collets 575E 198
collets ER 191
collets ER, class I 192
collets ER, sealed 193
collets Erickson 197
collets OZ 190
collets, sets 202,203
collets, wide range 256
combination arbors 218,219,223,230,240
conic bushes 106,131
coolant tubes 244/267
cross retaining screws 264
cross tables 90-92
cross tables driven 93
cutting-off holder VDI 166,167

D

dial indicators 276,277
dial test indicators 277
dividing heads 74-76,79
dividing plates for round tables 77,80
double vice 138
draw-off nuts 123
drill chuck arbors 220,225,231
drill chucks NC 222,227,233,241
drill chucks, keyless 108
drill chucks, universal 109,111
drill chucks, universal 109
drill chucks, universal 109,111
drill chucks, universal 110,111
drill chucks, universal 110,173
drill chucks, universal 110
drill chucks, universal 110
drilling machine vice 150
drive pins 130
driven tools DIN 5480 182/183
driven tools DIN 5482 184/185
driven tools TOEM 186



driver arbors for reamers.....	217	lathe chucks, stationary.....	82-84
driving tenons	267	lamps.....	306
E			
edge finders, electronically	275	machine vice, mechanically	148
edge finders, mechanical	275	magnetic plates	88
ejectors	267	micrometer sets.....	278
emergency collets	199	milling arbors, screw-on type.....	227,228,234,242
emergency stop boxes.....	305	milling drill sets	287
erosion vices.....	155-157	morse taper collets.....	198
extension sleeves MT.....	98,99	morse taper sleeves	209,220,221,225,232,241
F			
face drivers.....	130	morse taper sleeves VDI (F).....	171
face mill holders.....	219,223,230,241	O	
feather keys.....	266	O-rings	180
floating chucks.....	238	outside solid jaws	23
floating chucks VDI.....	174	P	
G			
gauge block sets.....	280	parallels	279
grid cube.....	96	pin gauges sets.....	281
H			
hard rev. jaws f. wedge bar chucks.....	30	pinions.....	26
hard rev. jaws f. Wescott chucks.....	32,33	plug gauges	282
hydraulic cylinder.....	62	plug gauges	284
I			
independent chucks cylindrical.....	35	power chucks, 2/3-jaws	51
independent chucks DIN 55026	36	power chucks, 2-jaws	50
independent chucks DIN 55027	37	power chucks, 3-jaws	52-56,59,60
independent chucks DIN 55029	38	power chucks, 4-jaws	57,58
inserts for boring heads.....	250	power vice, mechanically	142
inside solid jaws f. lathe chucks	23	prisms.....	209
J			
jaw turning rings	46-48,66	protection hoods	290-296
jaws for vices	137,141,143,144,146,160	protection hoods	297,300-302
K			
keys for coolant tubes	244	protection hoods	298,299,303,304
keys for lathe chucks	27	protection plugs VDI.....	180
L			
lathe chucks, 2-jaws.....	12	pull studs.....	245
lathe chucks, 3-jaws.....	13-16,20,22,28	pull studs.....	245
lathe chucks, 4-jaws.....	17,18,28	pull studs.....	246
lathe chucks, 6-jaws.....	21,29	pull studs.....	246
		pull studs.....	246
		pull studs.....	247
		pull studs.....	247
		R	
		reduction sleeves f. milling chucks	238
		reduction sleeves MT	98
		reduction sleeves VDI.....	179
		reduction sleeves, hydraulic chucks	99
		reduction sleeves, slotted VDI.....	179
		ring gauges	283
		ring gauges	285
		round jaws for chucks f. power chucks	65

round tables..... 74,79,80

S

safety drive rings..... 258
sanding belt holders 213
sanding belts..... 213
saw blade holder 238
screw jacks 87
screws for base jaws 27
screws Weldon 266
scrolls 26
seal kits for hydraulic cylinder 62
setting holder VDI 178
shrink chucks 229,235,243
soft solid jaws f. lathe chucks..... 25,29
soft solid jaws f. wedge bar chucks..... 31
soft solid jaws f. Wescott chucks..... 32,33
spacing collars 261,262
spare parts for vices 146
spindle sleeves..... 100
spindle stops..... 258
stands mechanical..... 278
stop for lathe chucks 48
stops for collets 203
stops for VDI 178
stops for vices..... 259
stops, universal 160,259
studs DIN 55027 26
studs DIN 55029..... 27
swivel bases for vices..... 137,146
synchro-tapping chucks..... 254,255

T

table vices 151
tailstocks 77,78
tangs 264
taper arbor 104,105
taper cleaners 260
tapping chucks, quick-change..... 251,252
tapping chucks, reversal..... 256
tapping collets 194-196
tapping inserts 253
tapping sleeves..... 102,103
telescopic arm for vices 151
testing arbors..... 242,272,273
testing arbors VDI..... 178,273
T-nuts 259
T-nuts for power chucks..... 65
tool holders VDI axial (C1-C4)..... 165,166

tool holders VDI radial (B1-B8)..... 163-165
tool holders VDI, square (D1-D2) 166
tool kits..... 216
tool maker's vices 153,154
tool posts Basic 210,211
tool posts Multisuisse..... 207-209
tool posts spare parts..... 212
tool racks..... 268
tool trolleys..... 268
toolholders for Mori Seiki 187
toolholders for Nakamura..... 188
top jaws, hard f. lathe chucks 24
top jaws, hard f. power chucks..... 64
top jaws, hard f. wedge bar chucks..... 31
top jaws, soft f. lathe chucks..... 25
top jaws, soft f. power chucks 64
top jaws, soft f. wedge bar chucks 31
tube center heads..... 124
tube center, dead..... 43,123,124
tube center, revolving 43,120-122,124,127

U

U-drill holder VDI (E1)..... 167

V

V- blocks 85,86
V- blocks magnetic..... 85
vices Carminati 158,159
vices hydraulically 145,147
vices pneumatically 139
vices type CMC 134,136
vices type DZM..... 138
vices type SVC..... 135
vices, 3-axis 149
vices, multiflex 140
vices, self-centering..... 152,153

W

wedge bar chucks 30
Weldon chucks 218,220,224,225,231,240
Weldon chucks with coolant ring..... 222,226,233
Wescott chucks 32,33
wrenches cross retaining screws..... 263
wrenches ER..... 263
wrenches OZ 263

Z

zero adjuster 274



